

# **Instructions for Use**

## **M3 and M4 Monitor M3046A Measurement Server M3001A Measurement Server Extensions M3015A & M3016A**

Part Number M3046-9000E  
Reordering Number: 453563481191  
Printed in Germany 06/03  
Fifth Edition

---

## **Notice**

This document contains proprietary information which is protected by copyright. All Rights Reserved. Reproduction, adaptation, or translation without prior written permission is prohibited, except as allowed under the copyright laws.

Philips Medizin Systeme Boeblingen GmbH  
Cardiac and Monitoring Systems  
Hewlett-Packard-Str. 2  
71034 Boeblingen  
Germany

Printed in Germany

## **Warranty**

The information contained in this document is subject to change without notice.

Philips Medical Systems makes no warranty of any kind with regard to this material, including, but not limited to, the implied warranties or merchantability and fitness for a particular purpose.

Philips Medical Systems shall not be liable for errors contained herein or for incidental or consequential damages in connection with the furnishing, performance, or use of this material.

© 1995-2003 Koninklijke Philips Electronics N.V.

All rights are reserved. Reproduction in whole or in part is prohibited without the prior written consent of the copyright holder.

Philips Electronics North America Corporation reserves the right to make changes in specifications or to discontinue any product at any time without notice or obligation and will not be liable for any consequences resulting from the use of this publication.

Microsoft, Windows NT and Windows 2000 are trademarks of Microsoft Corporation in the USA and other countries.

---

## Printing History

New editions of this document will incorporate all material updated since the previous edition. Update packages may be issued between editions and contain replacement and additional pages to be merged by a revision date at the bottom of the page. Note that pages which are rearranged due to changes on a previous page are not considered revised.

The documentation printing date and part number indicate its current edition. The printing date changes when a new edition is printed. (Minor corrections and updates which are incorporated at reprint do not cause the date to change.) The document part number changes when extensive technical changes are incorporated.

First Edition . . . . .	6/00
Second Edition . . . . .	11/00
Third Edition . . . . .	05/01
Fourth Edition . . . . .	04/02
Fifth Edition . . . . .	06/02

---

## Introduction

The M3001A Multi-Measurement Server and the M3046A Compact Portable Patient Monitor form a flexible, portable, battery or line powered patient monitor.

The M3001A Multi-Measurement Server and M3016A/M3015A Measurement Server Extensions acquire the physiological signals ECG, respiration, invasive and non-invasive blood pressure, oxygen saturation of the blood, partial pressure of carbon dioxide and temperature. These signals are converted into digital data, and processed before being communicated to the monitor.

The M3046A Compact Portable Patient Monitor receives the processed data from the Measurement Server or Measurement Extension, examines it for alarm conditions and displays it. The monitor also provides operating controls for the

user, an optional infrared interface for a printer, and a serial interface for connection to a standalone XE-50p strip chart recorder from GSI Lumonics.

Data can be transferred via the M3001A Multi-Measurement Server to and from other M3046A monitors and also the IntelliVue family of patient monitors.

The M3000A Multi-Measurement Server is not compatible with the M3046A monitor with Revision E software.

**Intended  
Use  
Statement**

The intended use for these devices are to monitor ECG, respiration, invasive and non-invasive blood pressure, oxygen saturation of the blood, partial pressure of carbon dioxide and temperature of adult, pediatric and neonatal patients; to display patient data and waves; to store patient data in a trend database; and to generate alarms and recordings. It is to be used in a hospital environment and for transport monitoring by health care professionals. It is not intended for home use.

**Monitors with  
a Wireless  
Network  
Connection**

Monitors with a wireless network connection are intended to be used by skilled persons, and are intended to be directly connected to the Publicly Available Interfaces (PAI). This product is subject to and compliant with the European Directive for Radio Equipment and Telecommunications Terminal Equipment 1999/5/EC, as noted in the Declaration of Conformity.

**Patient  
Population**

The devices are intended to be used for adult, pediatric and neonatal patients. The device must be used only on one patient at a time. EASI 12-lead ECG is only for use on adult and pediatric patients. ST Segment monitoring is restricted to adult patients only (see page 170 for further information).

**Environment**

The devices are intended to be used in a hospital environment and for transport monitoring by trained health care professionals inside and outside hospitals.

The devices are not intended for home use.

**Device Claims**

This is not a therapeutic device.

## **CE Compliance**

The Philips M3046A Compact Portable Patient Monitor complies with the requirements of the Council Directive 93/42/EEC of 14 June 1993 concerning medical devices and carries CE marking accordingly.



The system also complies with the Council Directive 1999/5/EC of 9 March 1999 concerning radio equipment and telecommunications terminal equipment. The following symbol, CE(!), means that this device is considered Class 2 radio equipment per Directive 1999/5/EC for which Member States may apply restrictions on putting the device into service or placing it on the market. This system is intended to be connected to the publicly available interfaces (PAI).

---

---

### **Warning**

**This product is Class 2 under the scope of the R&TTE. Be aware that France and Spain use frequencies other than those of the rest of the EEA. This means that products bought elsewhere might cause problems in France and Spain and should be avoided**

---

---

### **FCC Compliance (USA)**

This device complies with Part 15 of the 47 CFR FCC Rules. Operation is subject to the following two conditions:

- this device may not cause harmful radio interference, and
- this device must accept any radio interference received, including interference that may cause undesired operation.

### **RSS 210 Compliance (Canada)**

Operation of the device is subject to the following two conditions:

- this device may not cause interference, and
- this device must accept any interference, including interference that may cause undesired operation of the device.

### **Responsibility of the Manufacturer**

Philips Medical Systems only considers itself responsible for any effects on safety, reliability and performance of the equipment if:

- assembly operations, extensions, re-adjustments, modifications or repairs are carried out by persons authorized by Philips Medical Systems, and
- the electrical installation of the relevant room complies with national standards, and
- the instrument is used in accordance with the instructions for use.

To ensure safety, use only those Philips parts and accessories specified for use with the monitor. If other parts are used, Philips Medical Systems is not liable for any damage that these parts may cause to the equipment.

**Important**

United States federal law restricts this device to sale by, or on the order of, a physician.

---

## In This Book

This *Instructions for Use* is valid for the M3001A Measurement Server and M3046A Monitor with Revision E software and the M3015A and M3016A Measurement Server Extensions. It contains all the general information about the monitor. It is a good place for new users to start because it gives an introduction to the system and the way it works, shows you how to get started, and provides complete step by step key pushing information on how to use the monitor.

To enable you to find information easily, there is a contents list at the front of the Manual and a comprehensive index at the back.

---

### Warning

---

Warnings are information you should know to avoid injuring patients and personnel.

---

---

---

### Caution

---

Cautions are information you should know to avoid damaging your equipment.

---

---

## Conventions Used in This Book

## Who This Book is For

This book is intended for users who are familiar with the measurements being made, and already have experience of using monitoring equipment.

## Trademarks

The following are trademarks of Oridion Medical Inc.: “Microstream”, “FilterLine”, “Smart CapnoLine”, and “NIV Line”.





# Table of Contents

Intended Use Statement	4
CE Compliance	5
FCC Compliance (USA)	5
RSS 210 Compliance (Canada)	5
Responsibility of the Manufacturer	5
Important	6
Conventions Used in This Book	7
Who This Book is For	7
Trademarks	7
<b>Basic Operation</b>	<b>29</b>
A Quick Description of the Monitor	30
Front Panel Keys	30
Front of Monitor (M3046A)	31
Back of Monitor (M3046A)	31
Measurement Server (M3001A)	32
Measurement Connectors (M3001A)	32
Measurement Server with Invasive Measurement Set (M3001A #C06, #C18)	33
Measurement Connectors (M3001A #C06)	33
Measurement Server Extensions (M3015A & M3016A)	34
Measurement Server Extension Connectors	35
Main Screen	36
Before You Start to Use the Monitor	36
Basic Operation	38
The Four Hardkeys	38
The TouchStrip	39
The Arrows and the Dot	39
The SmartKeys and Softkeys	40
The Corner of the TouchStrip	41
Setting Up a Measurement	41
Setting Up a Wave	43

Basic Setup .....	44
Selecting a Wave for the Screen .....	44
Setting the Waves Speed .....	45
Switching Measurements On or Off .....	45
Checking and Changing the Alarm Limits .....	46
Printing a Copy of the Current Measurements .....	46
Recording Strips Locally .....	46
Adjusting the Volume .....	46
Adjusting the Screen Brightness .....	47
Setting the Date and Time .....	48
Recalling a QuickSet .....	48
Summary of the SmartKeys .....	49

## **Dealing with Alarms ..... 51**

Recommendation for Alarm Configuration .....	51
Recognizing Alarms .....	52
Patient Alarms .....	52
Technical Alarms .....	53
Reviewing Alarms .....	53
Dealing with Alarms .....	54
Latching and Non-Latching Alarms .....	54
Silencing Alarms .....	57
Suspending Alarms .....	57
Restarting Suspended Alarms .....	58
Checking and Changing the Alarm Limits .....	58
Setting Automatic Alarm Limits .....	59
Changing The Volume of the Alarm Chime .....	59
Alarm Recording .....	60
Patient Alarm Messages .....	61
Technical Alarm Messages (INOPs) .....	76

## **Admitting and Discharging Patients ..... 93**

Selecting the Patient Identification Menu .....	94
Admitting A New Patient .....	95
Changing the Patient Identification .....	95
Changing the Patient Category .....	95
Changing the Pacemaker Setting .....	96
Selecting a QuickSet .....	97

Transferring A Patient To Another Monitor .....	98
Transferring a Centrally Monitored Patient .....	98
Transferring the Patient with the Measurement Server .....	99
Transferring a Patient with the Monitor .....	102
Discharging a Patient .....	103
<b>Communicating with the Information Center .....</b>	<b>105</b>
Which Networks are used with the M3046A? .....	106
Optimizing Wireless LAN System Performance .....	107
Interacting with the Information Center .....	108
Connecting and Disconnecting from the Network .....	108
Operating Remotely at the Information Center .....	110
Recording and Printing at the Information Center .....	110
Configuring the Monitor Label .....	112
Assigning the Monitor to a Care Group .....	113
Troubleshooting the Connection to the Information Center .....	113
When Connecting a Monitor to the Network .....	113
During Operation .....	114
Viewing Information for Other Patients from the Bedside .....	115
Getting an Overview of the Monitors in Your Care Group .....	115
Viewing Patient Information from Another Monitor .....	117
<b>Measuring the ECG .....</b>	<b>121</b>
Considerations when Measuring ECG .....	122
Preparing to Measure ECG .....	122
About ECG Leads .....	124
ECG Leads Monitored .....	124
Placing the Electrodes for Measuring ECG .....	125
5-Electrode Set: .....	125
3-Electrode Set (Standard) .....	127
3-Electrode Set (MCL <sub>1</sub> ) .....	128
Placement for Paced Patients .....	129
10-Electrode Set .....	129
EASI ECG Lead Placement .....	129
Recommended Placement for Surgical Patients .....	131
Selecting the ECG Setup .....	131
Switching the ECG Measurement On and Off .....	132
Selecting the Source for the Heart Rate Numeric .....	132
Selecting the Volume of the Tone .....	133

Changing the Heart Rate Alarm Limits . . . . .	134
Enabling or Disabling ECG Heart Rate Alarm . . . . .	135
Choosing EASI or Standard Lead Placement . . . . .	135
Switching Pace Pulse Rejection On and Off . . . . .	135
Paced Patients . . . . .	135
Warnings for Paced Patients . . . . .	136
Switching Pace Pulse Rejection On and Off . . . . .	138
Setting the Number of ECG Channels . . . . .	138
Setting up the ECG Wave . . . . .	139
Selecting the ECG Wave Channel Setup . . . . .	139
Selecting the ECG Lead . . . . .	139
Changing the Size of the ECG Wave . . . . .	142
Changing the Size of All ECG Waves . . . . .	142
Getting a Cleaner or More Detailed ECG Wave . . . . .	142
Changing the Speed of the ECG Wave . . . . .	143
Selecting ECG Cascading through Empty Waves . . . . .	144
Selecting the Asystole Threshold . . . . .	144
Troubleshooting the ECG Measurement . . . . .	144
If the HR Numeric is Displayed . . . . .	144
If the HR Numeric Shows -?- . . . . .	144

## **Monitoring Arrhythmia . . . . . 147**

Introduction . . . . .	148
Levels of Arrhythmia Analysis . . . . .	149
Basic Arrhythmia . . . . .	149
Enhanced Arrhythmia . . . . .	150
Ensuring Accurate Arrhythmia Monitoring . . . . .	151
Alarm Priorities and Timeout Periods . . . . .	154
Timeout Periods . . . . .	154
Clearing the Timeout Period . . . . .	155
Alarm Chaining . . . . .	155
Overview . . . . .	155
Alarm Groupings . . . . .	155
Alarm Announcing . . . . .	156
Alarm Priority Chains . . . . .	157
Selecting the Arrhythmia Setup . . . . .	159
Switching Arrhythmia Analysis On and Off . . . . .	159
Selecting Single- or Multi-Lead Analysis . . . . .	160
Reviewing Beat Labels . . . . .	161
Relearning Arrhythmia . . . . .	161

Changing the Arrhythmia Alarm Limits . . . . .	162
Switching Arrhythmia Alarms On and Off . . . . .	164
Switching Alarms On and Off Individually . . . . .	164
Switching All Yellow Alarms On or Off . . . . .	164
Status Messages . . . . .	165
Rhythm Status Messages . . . . .	165
Ectopic Status Messages . . . . .	167
Troubleshooting the Arrhythmia Analysis . . . . .	168
<b>Monitoring ST Segment . . . . .</b>	<b>169</b>
Introduction . . . . .	170
The Measurement . . . . .	171
How the Algorithm Works . . . . .	171
Displayed ST Data . . . . .	171
Selecting the ST Setup . . . . .	172
Adjusting the measurement points . . . . .	172
Switching ST On and Off. . . . .	174
Changing the ST Alarm Limits. . . . .	175
Switching ST Alarms On and Off . . . . .	175
Troubleshooting the ST Measurement. . . . .	175
<b>Measuring Respiration Rate (RESP) . . . . .</b>	<b>177</b>
Preparing to Measure Respiration. . . . .	178
Placing the Electrodes for Measuring Respiration . . . . .	179
Selecting the Respiration Setup. . . . .	181
Selecting the Respiration Source and Switching Respiration On/Off. . . . .	181
Changing how Respiration is Detected. . . . .	182
Adjusting the Manual Respiration Detection Level . . . . .	183
Setting Up the Respiration Wave . . . . .	184
Changing the Size of the Respiration Wave . . . . .	184
Changing the Speed of the Respiration Wave . . . . .	184
Setting Up the Respiration Alarm . . . . .	184
Changing the Respiration Alarm Limits . . . . .	184
Changing the Apnea Alarm Delay . . . . .	185
Enabling or Disabling Respiration and Apnea Alarms . . . . .	185
Troubleshooting the Respiration Measurement. . . . .	186
If the RR Numeric is Still being Displayed . . . . .	186
If the RR Numeric Shows -?- . . . . .	186

<b>Measuring Non-invasive Blood Pressure (NBP)</b> .....	<b>187</b>
Preparing to Measure NBP .....	188
Starting and Stopping NBP Measurements...	192
Making a Single NBP Measurement .....	193
Making stat NBP Measurements .....	193
Making Automatic NBP Measurements .....	194
Using the NBP Cuff to Occlude Blood Vessels .....	195
Understanding the NBP Numerics .....	196
Selecting the NBP Setup .....	197
Switching the NBP Measurement On .....	197
Setting Up the NBP Alarms .....	198
Changing the alarm limits. ....	198
Enabling the alarms. ....	199
Troubleshooting the NBP Measurement .....	200
If the NBP Numeric Shows -?- .....	200
<b>Measuring Pressure, Invasively (PRESS)</b> .....	<b>203</b>
Preparing to Measure Pressure .....	204
Selecting a Label (and the Label Dependent Settings) .....	206
Zeroing the Transducer .....	207
Selecting the Pressure Setup .....	209
Switching the Pressure Measurement On .....	209
Setting Up the Pressure Wave .....	210
Changing the Size of the Pressure Wave .....	210
Optimizing the Waveform .....	210
Non-Physiological Artifact Suppression .....	211
Changing the Speed of the Pressure Wave .....	211
Setting Up the PRESS Alarms .....	211
Changing the alarm limits. ....	211
Enabling the alarms. ....	212
Setting PRESS as the source for the Pulse .....	213
Calibrating a Disposable Transducer (M1567A/M1568A) .....	213
Entering a Known Calibration Factor .....	213
Calibrating a CPJ840J6 Transducer .....	214
Doing a Mercury Calibration .....	215
Troubleshooting the Pressure Measurement .....	218
If the Pressure Numeric is Displayed .....	218
If the Pressure and Pulse Numerics Show -?- .....	218
If the Pulse Numeric Shows -?- .....	219

<b>Measuring the Oxygen Saturation of Arterial Blood (SpO<sub>2</sub>)</b> . . . . .	<b>221</b>
Preparing and Measuring SpO <sub>2</sub> . . . . .	222
Applying the Reusable Transducers . . . . .	226
The Adult Finger Transducer (M1191A) . . . . .	226
Selecting the SpO <sub>2</sub> Setup. . . . .	229
Switching the SpO <sub>2</sub> Measurement On . . . . .	229
Setting Up the Tone Modulation. . . . .	230
Switching the Tone Modulation On . . . . .	230
Changing the Volume of the QRS Tone . . . . .	230
Setting Up the SpO <sub>2</sub> Alarms . . . . .	231
Changing the alarm limits . . . . .	231
Adjusting the Desaturation Alarm Limit . . . . .	232
Enabling the alarms . . . . .	232
Testing the Alarm . . . . .	232
Setting Up the Pleth Wave . . . . .	233
Changing the Speed of the PLETH Wave . . . . .	233
Setting PLETH as the source for the Pulse . . . . .	233
Troubleshooting the SpO <sub>2</sub> /PLETH Measurement . . . . .	234
If the Pulse Numeric Shows -?- . . . . .	234
If the SpO <sub>2</sub> and Pulse Numerics Show -?- . . . . .	234
 <b>Measuring Temperature (TEMP)</b> . . . . .	 <b>237</b>
Preparing to Measure Temperature . . . . .	238
Selecting the TEMP Setup . . . . .	239
Switching the TEMP Measurement On. . . . .	239
Changing the TEMP Label . . . . .	240
Selecting the Δ TEMP Setup . . . . .	240
Switching the ΔTEMP Measurement On. . . . .	241
Selecting the Differential Temperature Source . . . . .	241
Setting Up the TEMP Alarms. . . . .	242
Changing the alarm limits. . . . .	242
Enabling the alarms. . . . .	242
Troubleshooting the TEMP Measurement . . . . .	243
If the TEMP Numeric Shows -?- . . . . .	243
 <b>Measuring Carbon Dioxide Using the Mainstream Method (M3016A)</b> .	 <b>245</b>
The CO <sub>2</sub> Measurement. . . . .	246
Preparing to Measure CO <sub>2</sub> . . . . .	247

Selecting the CO <sub>2</sub> Setup . . . . .	249
Switching the CO <sub>2</sub> Measurement On . . . . .	249
Selecting the Respiration Rate Source and Switching AwRR On/Off . . . . .	250
Setting up the Corrections . . . . .	251
Setting Up the CO <sub>2</sub> and AwRR Alarms . . . . .	252
Changing the CO <sub>2</sub> alarm limits . . . . .	252
Enabling the CO <sub>2</sub> alarms . . . . .	252
Changing the AwRR alarm limits . . . . .	252
Changing the Apnea Alarm Delay . . . . .	253
Enabling or Disabling AwRR and Apnea Alarms . . . . .	253
Troubleshooting the CO <sub>2</sub> Measurement . . . . .	254
If the CO <sub>2</sub> Numerics Show -?- . . . . .	254
If the CO <sub>2</sub> Numeric is Displayed with a ? . . . . .	255
If the CO <sub>2</sub> Wave is Clipped . . . . .	255
If the CO <sub>2</sub> Readings are Low . . . . .	255
If the CO <sub>2</sub> Readings are High . . . . .	255

## **Measuring Carbon Dioxide Using the Microstream Method (M3015A) 257**

The CO <sub>2</sub> Measurement . . . . .	258
Preparing to Measure CO <sub>2</sub> . . . . .	259
Selecting the Accessories . . . . .	259
Setting up Microstream CO <sub>2</sub> . . . . .	260
Removing Exhaust Gases from the System . . . . .	261
Selecting the CO <sub>2</sub> Setup . . . . .	262
Switching the CO <sub>2</sub> Measurement On . . . . .	262
Selecting the Respiration Rate Source and Switching AwRR On/Off . . . . .	263
Setting up the N <sub>2</sub> O Correction . . . . .	264
Setting Up the CO <sub>2</sub> and AwRR Alarms . . . . .	264
Changing the CO <sub>2</sub> alarm limits . . . . .	264
Enabling the CO <sub>2</sub> alarms . . . . .	265
Changing the AwRR alarm limits . . . . .	265
Changing the Apnea Alarm Delay . . . . .	265
Enabling or Disabling AwRR and Apnea Alarms . . . . .	266
Troubleshooting the CO <sub>2</sub> Measurement . . . . .	266
If no CO <sub>2</sub> Numeric and Wave are Displayed . . . . .	266
If the CO <sub>2</sub> Numerics Show -?- . . . . .	266
If the CO <sub>2</sub> numerics are displayed with a ? . . . . .	268
If the CO <sub>2</sub> Wave is Clipped . . . . .	268
If the CO <sub>2</sub> Values are Low . . . . .	268
If the CO <sub>2</sub> values are High . . . . .	269



<b>Examining Trends and Events</b> .....	<b>271</b>
Viewing the Trend .....	272
Selecting a Short or Long Term Trend .....	272
Viewing the Earlier or Later Data .....	272
Viewing the Data for other Measurements .....	272
Printing and Recording the Trend Data .....	273
Printing the Page of Data from the Screen .....	273
Printing a Set of Trend Data .....	273
Recording Trend Data .....	273
Erasing all the Trend Data .....	274
Storing Events .....	274
Storing an Event Manually .....	274
Inserting a Reference Signal in the Event .....	274
Storing an Event Automatically .....	275
Reviewing Events .....	275
Keeping an Event for Future Reference .....	275
Reviewing the Numerics for an Event .....	276
Reviewing the Wave Strips for an Event .....	276
Printing or Recording an Event .....	277
Deleting an Event .....	277
Deleting all the Events .....	277
Stopping Printouts .....	278
Stopping the Current Printout .....	278
Stopping All Printouts .....	278
<b>Cleaning</b> .....	<b>279</b>
General Notes on Cleaning .....	280
Cleaning .....	280
Disinfecting .....	282
Preventing Cross Contamination .....	285
Cleaning the Monitor, Server, Server Extension and Mounting .....	286
Cleaning, Disinfecting and Treating the Transducers for the Prevention of Cross Contamination .....	287
ECG Cables and Leads .....	287
Cleaning the ECG Cables .....	287
Disinfecting the ECG Cables .....	288
Treating the ECG Cables to Prevent Cross Contamination .....	288

NBP Cuff . . . . .	289
Cleaning the Disposable NBP Cuff . . . . .	289
Cleaning and Treating the Reusable NBP Cuff for the Prevention of Cross Contamination . . . . .	290
PRESS Transducer . . . . .	292
Cleaning the PRESS Transducer . . . . .	292
Treating the PRESS Transducer for the Prevention of Cross Contamination . . . . .	293
SpO <sub>2</sub> Transducer . . . . .	295
TEMP Probes . . . . .	296
Mainstream CO <sub>2</sub> Transducer and Reusable Airway Adapters . . . . .	297
Cleaning the M1460A CO <sub>2</sub> Transducer . . . . .	297
Treating the M1460A CO <sub>2</sub> Transducer for the Prevention of Cross Contamination . . . . .	298
M1465A/14363A Airway Adapters . . . . .	299
Microstream CO <sub>2</sub> (Sidestream) Accessories . . . . .	300

**Maintenance . . . . . 301**

Maintenance Checks . . . . .	302
Inspecting the Monitor, Measurement Server and Measurement Server Extension . . . . .	304
Inspecting the Cables and Cords . . . . .	305
Testing that the System Functions . . . . .	305
Finding Intermittent Status . . . . .	307
Testing Visual and Auditory Alarms . . . . .	308

**Using Your Monitor in Patient Transport . . . . . 309**

Using a Vehicle 12V Supply . . . . .	310
Using New Batteries . . . . .	310
Maintaining the Battery . . . . .	311
Finding Out How Much Charge is in the Battery . . . . .	311
Finding Out How Much Operating Time Remains . . . . .	312
Changing the Battery . . . . .	312
If the Battery is Discharged (Flat) . . . . .	313
If the Battery Needs Conditioning . . . . .	313
Troubleshooting Battery Operation . . . . .	314
Understanding the Battery LED . . . . .	314
Understanding Messages in the Battery Gauge . . . . .	315
Understanding Battery Technical Alarms (INOPs) . . . . .	315

<b>Installing Your Monitor</b> .....	<b>317</b>
Warnings and Precautions .....	318
Patient Safety .....	318
Patient Leakage Current .....	318
Preparing to Install Your Monitor .....	318
Power Source Requirements .....	318
Protecting against Electric Shock .....	319
Equipotential Grounding .....	320
Combining Equipment .....	320
Environment .....	321
Explanation of symbols used: .....	322
Installing Your Monitor .....	325
Unpacking the Monitor .....	325
Installing the Monitor .....	326
Connecting the Measurement Server... ..	327
Attaching the Monitor to a Mount .....	329
Attaching the Measurement Server to a Mount .....	330
Connecting to the Information Center .....	331
Connecting to the Nurse Call Relay .....	331
Connecting to the ECG Output or Marker Input .....	331
Using an Additional Display .....	332
Basic Trouble shooting .....	333
Connecting a Printer .....	335
Selecting a Printer .....	335
Connecting a Local Printer .....	337
Connecting a Remote Printer .....	337
Trouble-shooting the Printer	
Connection .....	338
Connecting a Local Recorder .....	339
Fitting and Removing the Rubber Bezel Protector .....	341
Disposing of the Monitor, Measurement Server and Measurement Server Extension .....	343
 <b>Configuration</b> .....	 <b>345</b>
Who this Chapter is For .....	345
What you can Configure .....	345
How do I get into Configuration Mode? .....	346
How do I leave Configuration Mode? .....	347

Configuration Features . . . . .	348
How does Configuration Mode Work? . . . . .	348
How do I Configure a Quick Set? . . . . .	351
How do I configure General Settings . . . . .	352
Extra Configuration for the Bed to Bed Overview . . . . .	353
Changing What Happens When Another Monitor in the Care Group has an Alarm . . . . .	353
Changing Whether the Care Group Status is Displayed . . . . .	353
Extra Configuration for the ECG Measurement . . . . .	354
Selecting the Maximum Number of ECG Channels . . . . .	354
Selecting How ECG Filtering Changes during ESU . . . . .	354
Selecting the ECG Wave Default Size . . . . .	354
Selecting the Color for the ECG . . . . .	355
Setting the Tachycardia Alarm Limit . . . . .	355
Setting the Bradycardia Alarm Limit . . . . .	355
Setting the Lead Fallback mode . . . . .	356
Displaying “All ECG ALARMS OFF” INOP . . . . .	356
Extra Configuration for the Arrhythmia Analysis . . . . .	357
Setting Time-out Periods for Arrhythmia Yellow Alarms . . . . .	357
Setting the Pause Alarm Threshold . . . . .	357
Displaying an Arrhythmia Off Message . . . . .	357
Displaying “SOME ECG ALARMS OFF” INOP . . . . .	358
Extra Configuration for the ST Measurement . . . . .	358
Adjusting the ISO, J and ST Points . . . . .	358
Extra Configuration for the RESP Measurement . . . . .	359
Selecting the Color for the RESP . . . . .	359
Extra Configuration for the SpO <sub>2</sub> Measurement. . . . .	359
Changing the Averaging Time for SpO <sub>2</sub> . . . . .	359
Changing the Time Elapsed Before the Low Alarm . . . . .	359
Changing the Time Elapsed Before the High Alarm . . . . .	360
Selecting the Color for SpO <sub>2</sub> . . . . .	360
Selecting INOP Suppression during NBP Measurements . . . . .	360
Setting the Desaturation Alarm Delay . . . . .	360
Extra Configuration for the NBP Measurement . . . . .	361
Selecting the NBP Unit . . . . .	361
Selecting the Reference for the Measurement Method . . . . .	361
Selecting the Color for the NBP . . . . .	361
Switch on a Beep at the end of the Measurement . . . . .	361
Selecting Clock-synchronized Start Time . . . . .	361
Selecting the Pressure for Venipuncture Mode . . . . .	362

Extra Configuration for the PRESS Measurement . . . . .	362
Setting Up the PRESS Filter . . . . .	362
Setting Up to Measure Mean Pressure Only . . . . .	362
Enabling PRESS Transducer Calibration . . . . .	363
Non-Physiological Artifact Suppression . . . . .	363
Selecting the Unit . . . . .	363
Selecting the Color for the Pressure . . . . .	363
Extra Configuration for the TEMP Measurement. . . . .	364
Selecting the Unit for the Temperature Measurement . . . . .	364
Selecting the Color for TEMP . . . . .	364
Extra Configuration for the $\Delta$ TEMP Measurement . . . . .	364
Selecting the Unit for the $\Delta$ Temperature Measurement . . . . .	364
Selecting the Color for $\Delta$ TEMP . . . . .	365
Extra Configuration for the CO <sub>2</sub> Measurement. . . . .	365
Selecting the Unit for the CO <sub>2</sub> Measurement . . . . .	365
Selecting the Color for CO <sub>2</sub> . . . . .	365
Selecting Sampling Method for EtCO <sub>2</sub> (and ImCO <sub>2</sub> for the Sidestream Method) . . . . .	365
Selecting ImCO <sub>2</sub> On/Off . . . . .	365
Selecting Humidity Correction Method for CO <sub>2</sub> . . . . .	366
Extra Configuration for Transferring A Patient . . . . .	366
Changing What Happens Automatically . . . . .	366
Changing Which Settings are Used . . . . .	367
Naming the Monitor . . . . .	367
Entering the Hospital Name . . . . .	368
Configuring the Alarms . . . . .	369
Selecting the Alarms Setup . . . . .	369
Changing How Long Alarms Stay Suspended . . . . .	369
Let User be Reminded of Suspended Alarms . . . . .	370
Changing How Alarms Behave Until Silenced . . . . .	370
Changing the Alarm Reminder Behavior . . . . .	371
Changing the Alarm Reminder Time . . . . .	371
Changing Whether Numerics Blink . . . . .	371
Changing the Conditions for the Nurse Call Relay . . . . .	372
Enable Automatic Main Alarms Suspended State . . . . .	372
Selecting Where to Make Alarm Recordings . . . . .	373
Extra Configuration for the Events . . . . .	373
Setting Up So that Events are Stored Automatically . . . . .	373

Extra Configuration for the Monitor . . . . .	374
Configuring the QRS Sound . . . . .	374
Configuring the Alarm Sound . . . . .	374
Configuring the Prompt Volume . . . . .	375
Setting the Brightness for Battery Operation . . . . .	375
Disabling the Measurement Server Keys . . . . .	375
Changing Whether the Units are Displayed . . . . .	375
Changing ESU Filtering . . . . .	376
Selecting Measurements for AutoLimits . . . . .	376
Configuring How to Exit from Windows . . . . .	376
Changing Whether the Monitor Should be Connected to the Network . . . . .	377
Changing Whether the Monitor can be Controlled Remotely . . . . .	377
Making the Altitude Setting . . . . .	377
Changing Which Alarms Trigger a Recording . . . . .	378
Changing Whether a Printer is to be attached . . . . .	378
Selecting the Format for Short Reports . . . . .	378
Selecting the Format for Long Reports . . . . .	379
List of Configurable Settings . . . . .	380
General Settings . . . . .	380
Quick Set Configuration List for the Measurements . . . . .	380
Quick Set Configuration List for Monitoring Settings . . . . .	387

**Monitor and Measurement Specifications . . . . . 393**

Monitor and Measurement Server Safety Specifications . . . . .	394
Monitor Physical Specifications . . . . .	394
Size . . . . .	394
Weight . . . . .	394
Monitor Environmental Specifications . . . . .	395
Temperature Range (without wireless network) . . . . .	395
Temperature Range (with wireless network) . . . . .	395
Humidity Range . . . . .	395
Altitude Range . . . . .	395
Electrical Specifications . . . . .	395

Monitor Performance Specifications . . . . .	396
Display . . . . .	396
Indicators . . . . .	396
Interfaces . . . . .	396
Battery (optional) . . . . .	397
Real-time Clock . . . . .	398
Active Settings and Stored Data . . . . .	398
Trends . . . . .	398
Measurement Server Physical Specifications . . . . .	399
Size . . . . .	399
Weight . . . . .	399
Measurement Server Environmental Specifications . . . . .	399
Temperature Range . . . . .	399
Humidity Range . . . . .	399
Altitude Range . . . . .	399
ECG Specifications . . . . .	400
Differential Input Impedance . . . . .	400
Common Mode Rejection Ratio . . . . .	400
Electrode Offset Potential Tolerance . . . . .	400
Auxiliary Current . . . . .	400
Baseline Recovery Time . . . . .	400
Input Signal Range . . . . .	400
Calibration . . . . .	400
Bandwidth . . . . .	401
Arrhythmia Specifications . . . . .	401
Cardiotach . . . . .	401
PVC Rate . . . . .	401
Limit Alarms for Heart Rate . . . . .	401
Alarm Delay . . . . .	402
Extreme Tachy . . . . .	402
Extreme Brady . . . . .	402
Run PVCs Limit . . . . .	402
PVCs Rate Limit . . . . .	402
Vent Tach HR . . . . .	402
Vent Tach Run Limit . . . . .	403
Vent Rhythm Run Limit . . . . .	403
SVT HR Limit . . . . .	403
SVT Run Limit . . . . .	403
Asystole Threshold . . . . .	403
Pause Threshold . . . . .	403

ST Specifications . . . . .	404
ST Numeric . . . . .	404
ST High Limit . . . . .	404
ST Low Limit . . . . .	404
RESP Specifications . . . . .	404
Bandwidth . . . . .	404
Noise . . . . .	404
Respiration Rate . . . . .	404
Calibration Signal . . . . .	405
Respiration Limit Alarms . . . . .	405
Apnea Alarm . . . . .	405
SpO <sub>2</sub> Specifications . . . . .	406
Range . . . . .	406
Accuracy . . . . .	406
Resolution . . . . .	406
Limit Alarms . . . . .	406
Pulse Rate Measurement Range . . . . .	407
Pulse Rate Limit Alarms . . . . .	407
Display Update Period . . . . .	407
SpO <sub>2</sub> Transducers . . . . .	407
NBP Specifications . . . . .	408
Cuff Inflation Rate . . . . .	408
Auto Mode Repetition . . . . .	408
STAT Mode Cycle Time . . . . .	408
Venipuncture Mode Inflation . . . . .	408
Adult/pediatric: . . . . .	408
Measurement Time . . . . .	408
Accuracy . . . . .	409
Heart Rate Range . . . . .	409
Measurement Validation . . . . .	409
Adult Mode . . . . .	409
Pediatric Mode . . . . .	409
Neonatal Mode . . . . .	410



PRESS Specifications .....	410
Input Sensitivity .....	410
Zero Adjustment .....	410
Gain Accuracy (excluding transducers) .....	410
Overall Accuracy (including transducers) .....	411
Transducer Output Impedance: .....	411
Volume Displacement (CPJ840J6 Transducer) .....	411
Measurement Range: .....	411
Frequency Response: .....	411
Limit Alarms .....	411
Pulse Rate Measurement Range .....	411
Pulse rate Limit Alarms .....	411
TEMP Specifications .....	412
Measurement Range .....	412
Average Time Constant .....	412
Test Temperature .....	412
Limit Alarms .....	412
Measurement Server Extension Physical Specifications (M3015A and M3016A) .....	412
Size .....	412
Weight .....	412
Measurement Server Extension Environmental Specifications (M3015A and M3016A) .....	413
Temperature Range .....	413
Humidity Range .....	413
Altitude Range .....	413
M3016A CO <sub>2</sub> Mainstream Measurement Specifications .....	413
Measurement Range .....	413
Warm-up Time .....	413
Accuracy ( <i>after 20 minutes warm-up and calibration</i> ) .....	414
Resolution .....	414
Stability .....	414
Endtidal CO <sub>2</sub> (etCO <sub>2</sub> ) Limit Alarms .....	414
Inspired minimum (imCO <sub>2</sub> ) High Limit Alarm .....	414
Rise Time .....	414

M3015A CO <sub>2</sub> Microstream Measurement Specifications	415
Measurement Range	415
Warm-up Time	415
Accuracy ( <i>after 20 minutes warm-up</i> )	415
Resolution	415
Sample Flow Rate	415
Rise Time	415
Gas Sampling Delay Time	416
Endtidal CO <sub>2</sub> (etCO <sub>2</sub> ) Limit Alarms	416
Inspired minimum (imCO <sub>2</sub> ) High Limit Alarm	416
M3015A/M3016A AwRR Specifications	416
Range	416
Accuracy	416
Limit Alarms	417
Apnea Alarm	417
M3015A/M3016A Press Specifications	417
M3015A/M3016A Temp. Specifications	417
M3015A/M3016A Difference Temperature Specifications	418
Measurement Range	418
Accuracy (excluding probe)	418
Electromagnetic Compatibility (EMC) Specifications	418
Accessories Compliant with EMC Standards	418
Electromagnetic Emissions	418
Electromagnetic Immunity	419
Recommended Separation Distance	420
Performing Safety and Performance Tests	423

## **Accessories and Ordering Information . . . . . 425**

ECG Accessories	426
Trunk Cable	426
3-Electrode Cable Sets	426
5-Electrode Cable Sets	427
10-Electrode Cable Sets	427
3-Electrode One Piece Cables	427
5-Electrode One Piece Cables	428
Set Combiner	428
Set Organizer	428
Intra-Atrial (Not Available in the U.S.A.)	428
Bedsheet Clip	428

SpO <sub>2</sub> Accessories . . . . .	429
Philips Reusable Transducers . . . . .	429
Disposable Transducers . . . . .	429
NBP Accessories . . . . .	431
PRESS Accessories . . . . .	434
Pressure Transducer . . . . .	434
Disposable Pressure Transducers . . . . .	434
Accessories for 1290C Pressure Transducers . . . . .	434
PULSION PiCCO Monitoring Kits . . . . .	434
Mainstream CO <sub>2</sub> Accessories . . . . .	435
Microstream CO <sub>2</sub> Accessories (Sidestream) . . . . .	436
TEMP Accessories . . . . .	437
Reusable Temperature Probes . . . . .	437
Disposable Temperature Probes . . . . .	437
Monitor Mounting Options . . . . .	438
Monitor Accessory Options . . . . .	438
Server Mounting Options . . . . .	439
Recorder . . . . .	439
Recorder Mounting Options . . . . .	439
Recorder Paper . . . . .	439



# Basic Operation

This chapter includes general operating principles of the monitor (how to read the information, how to change measurements)

- A Quick Description of the Monitor. . . . .30
- Before You Start to Use the Monitor . . . . .36
- Basic Operation. . . . .38
- Basic Setup . . . . .44
- Summary of the SmartKeys . . . . .49

---

Note

*Important  
Information  
about Moni-  
tor compati-  
bility*

There are two versions of the M3046A monitor: M3 and M4. The M3 has 3 wave channels and the M4 has 4 wave channels. The M4 can be used with the Measurement Extensions M3015A and M3016A, which allow measurement of CO<sub>2</sub> and a second pressure or second temperature.

To allow easy recognition of the M4, also from a distance, there is a yellow label on the side of the carrying handle.

There are also different options available. The exact performance of your monitor will depend on which options are included. Some sections of this manual apply to particular options and may not be applicable to your monitor.

The Release E M3046A monitor is compatible with the M3001A Multi-Measurement Server. None of these parts are compatible with M3046A Release D software or earlier, or any release of M3000A. To check which software revisions are on your equipment, press Setup then select **Revisions**.

---

---

---

**Warning**

---

---

**Do not use portable phones in the vicinity of the monitor. Portable phones may generate excessive radiated fields which can disturb the specified function of the monitor.**

---

---

---

---

**Warning**

---

---

**DO NOT TOUCH THE PATIENT, OR TABLE OR INSTRUMENTS DURING DEFIBRILLATION.**

---

---

---

## A Quick Description of the Monitor



This symbol indicates that you should consult accompanying documents (this guide), and particularly any warning messages.



This symbol on the handle of the monitor indicates that the monitor has a wireless network interface.

For an explanation of any of the other symbols on this monitor, see “Explanation of symbols used:” on page 322.

### Front Panel Keys

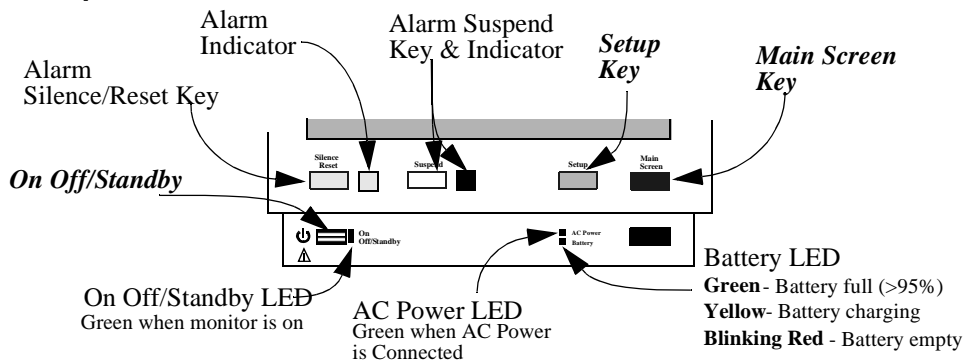

### Front of Monitor (M3046A)

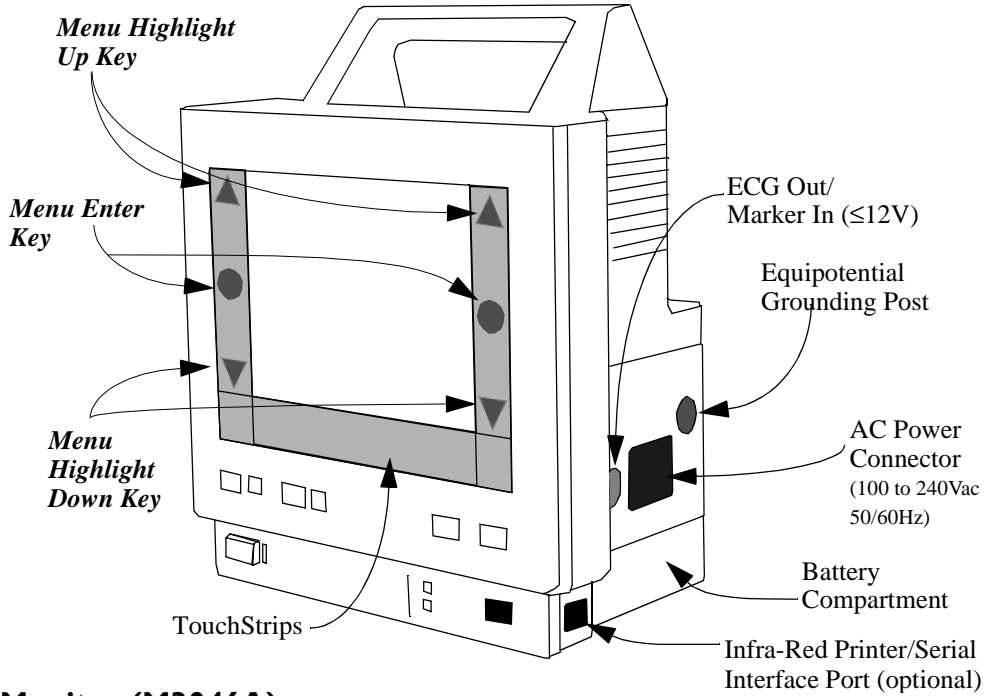

### Back of Monitor (M3046A)

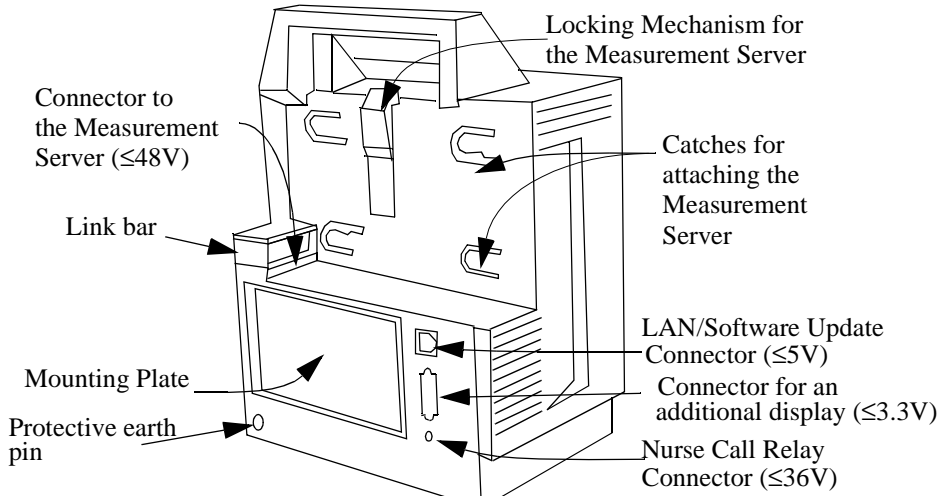

## Measurement Server (M3001A)

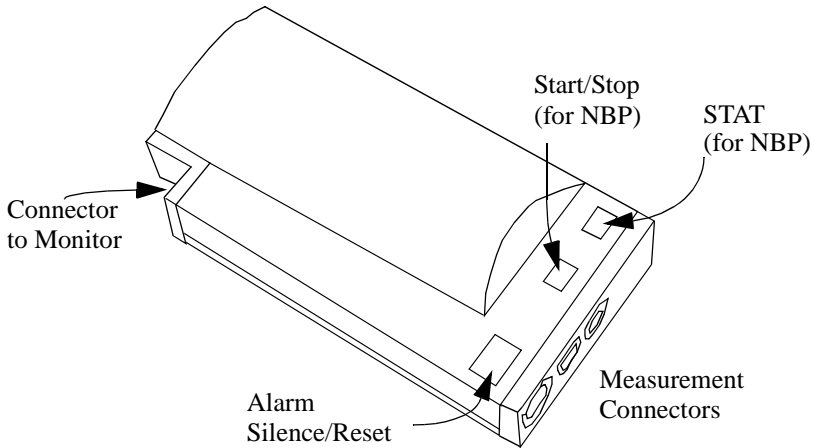

## Measurement Connectors (M3001A)

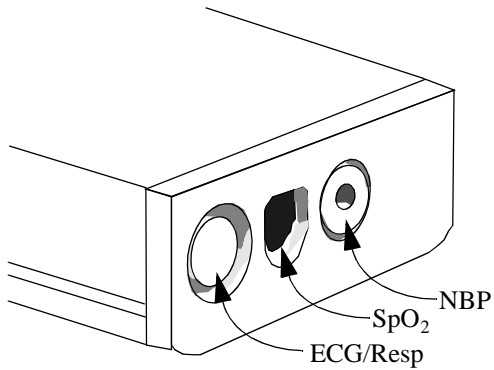



## Measurement Server with Invasive Measurement Set (M3001A #C06, #C18)

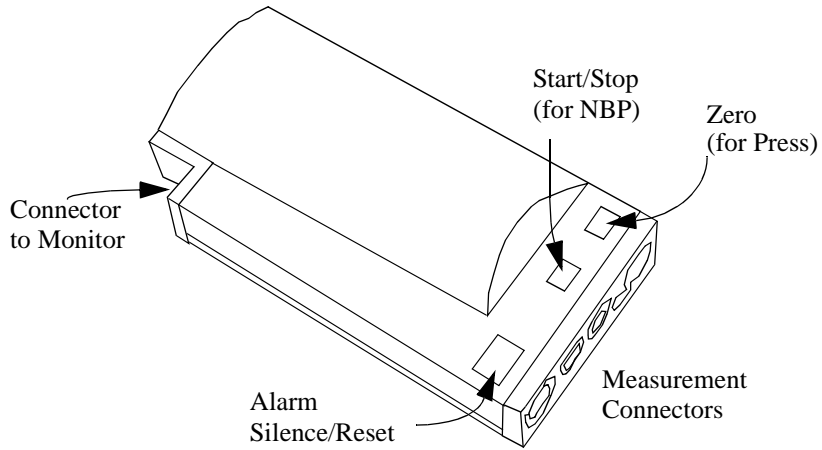

Note:  
If a Measurement Server Extension with a second pressure capability is connected, zero is applied to both pressures

## Measurement Connectors (M3001A #C06)

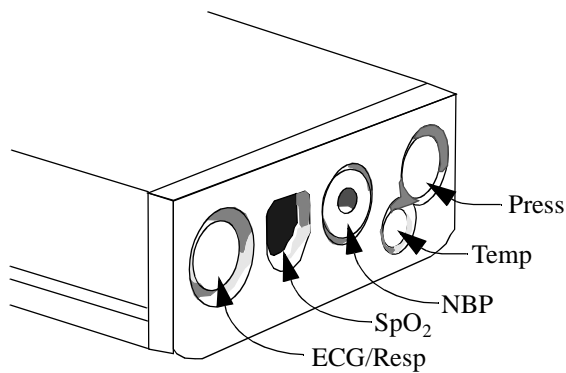

Note:  
Press and Temp cannot be used at the same time.

## Measurement Server Extensions (M3015A & M3016A)

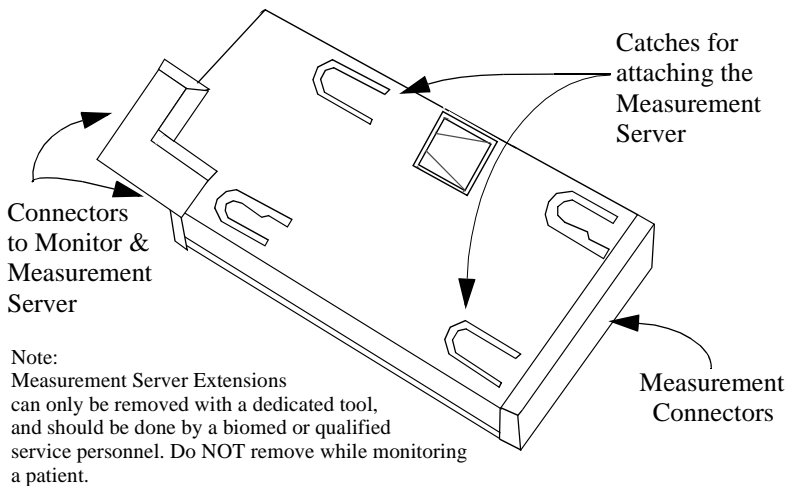

M3015A	with Microstream <sup>®</sup> CO <sub>2</sub>
M3015 #C06	with Microstream <sup>®</sup> CO <sub>2</sub> plus Invasive Pressure and Temperature
M3016A #A01	with Mainstream CO <sub>2</sub> plus Invasive Pressure and Temperature
M3016A #A02	Invasive Pressure and Temperature only (no CO <sub>2</sub> )

## Measurement Server Extension Connectors

### M3015A Measurement Server Extension

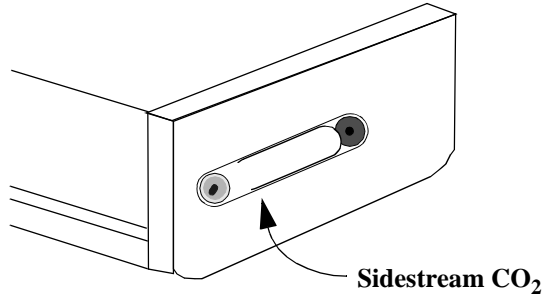

### M3015A #C06 Measurement Server Extension

Note:  
Press and Temp  
cannot be used  
at the same time  
on the same Extension

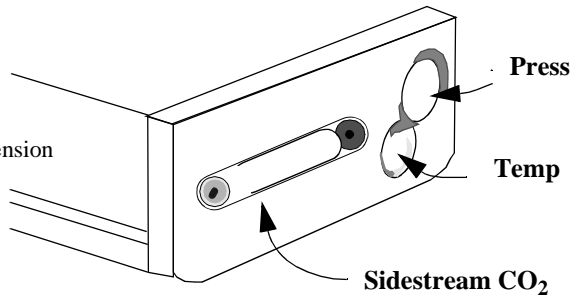

### M3016A Measurement Server Extension

Note:  
Press and Temp  
cannot be used  
at the same time  
on the same Extension

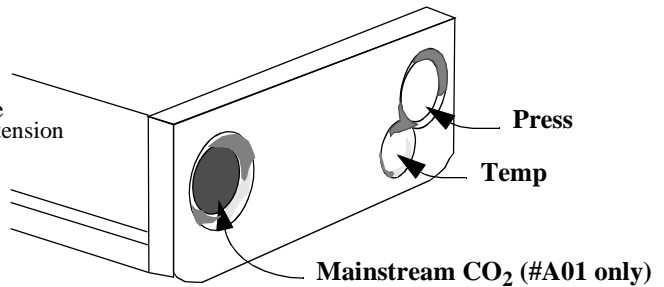

## Before You Start to Use the Monitor

### Main Screen

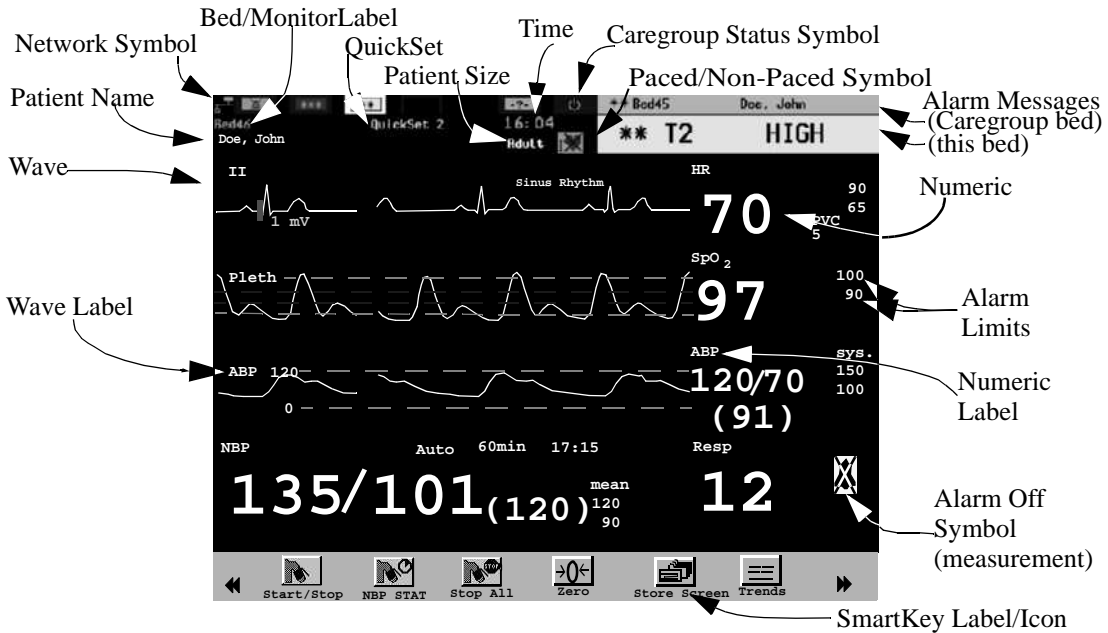

You can return to the display with the waves and the numerics at any time by pressing the blue **Main Screen** key

---

## Before You Start to Use the Monitor

Before you start to take measurements for a patient, carry out the following checks on the M3046A Monitor, the M3001A Measurement Server and the M3015A/M3016A Server Extensions, where present:

- Check for any mechanical damage.
- Check all the external leads, plug-ins and accessories.
- Check all the functions of the instrument which will be needed to monitor the patient, and ensure that the instrument is in good working order.

---

**Warning**

---

**Do not use the System for any monitoring procedure on a patient if the monitor is not working properly, or if it is mechanically damaged. Contact the hospital biomedical engineer, or your supplier.**

---

---

**Step 1.** Switch on the monitor. A self test is performed. (If there are any errors, see “Basic Trouble shooting” on page 333).

After the self-test, the monitor is ready to use. If you need to make any changes to the operation or the setup, see the section “Basic Operation”.

**Step 2.** Make sure the Measurement Server is connected to the monitor.

**Step 3.** If the patient is already attached to the Measurement Server, you should see the configured waves and numerics on the display, otherwise

- a. Attach any electrodes, probes, or transducers to the patient, or insert any pressure catheters required for monitoring.
- b. Connect the electrodes, probes and transducers to the Measurement Server.

## Basic Operation

You operate the monitor using

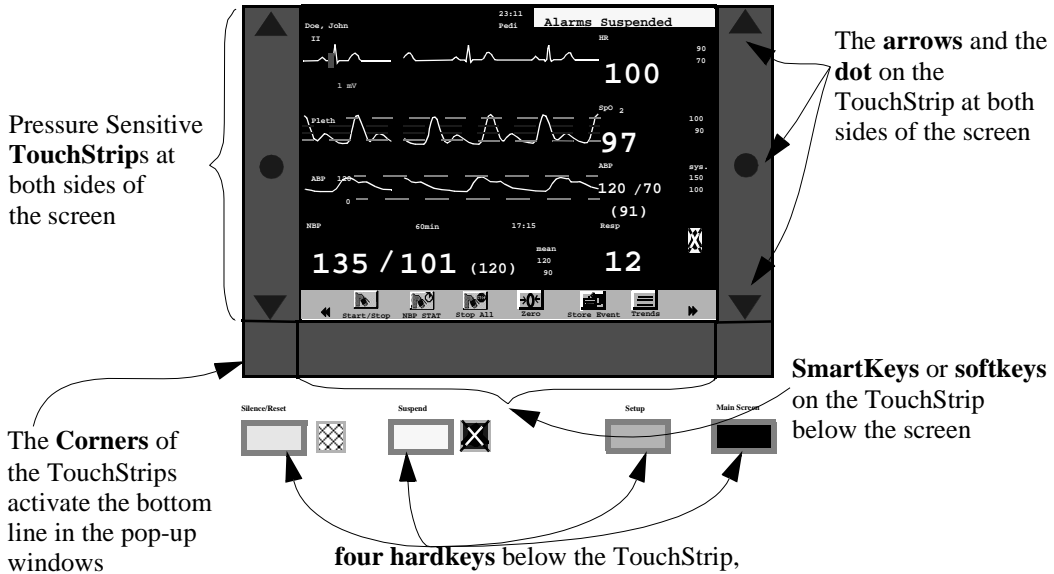

### The Four Hardkeys

**Silence/Reset** Use this to stop the audible alarm signal, and to reset alarms indicators for measurements that are no longer in an alarm condition.

- Suspend** Use this to stop the monitor checking for patient and technical (INOP) alarm conditions. To restart checking, press this key again.  
The Alarm Suspend indicator beside the key lights while the alarms are suspended.  
Depending on the configuration, the monitor may start checking again automatically after a fixed time (the amount of time for which the alarms will stay suspended is displayed in this case).
- Setup** Use this key to setup the monitor. All of the monitor setup can be accessed from the setup menu, along with the measurements for the Measurement Server that is connected, even if the measurement is not displayed on the screen.
- Main Screen** Use this key to return to the main screen with the waves and numerics at any time.

## The TouchStrip

The TouchStrips at the left and right of the screen, and below it have two pressure levels

- Touch** Press lightly on the TouchStrip to **highlight** something on the screen. If you are on the main screen, touching the TouchStrip will highlight the wave, numeric or SmartKey closest to your finger.
- Press** Press harder on the TouchStrip to **select** the currently highlighted item.

Practice a few times to get to know the pressure difference between touching and pressing reliably - you can practice by first highlighting and then selecting the “Trends” SmartKey (press the blue **Main Screen** key to get back to the main monitoring screen).

## The Arrows and the Dot

In a menu, touch the up or down arrow on the TouchStrip to move the highlight to the next item.

If you hold your finger on the arrow, the highlight will continue moving through the items in the menu.

Press on the dot to select the item.

*Note*—You can also glide your finger to “drag” the highlight.

If you glide your finger to the arrow at the top or bottom of the TouchStrip and hold it there, the highlight will continue moving through the items in the menu at the same speed.

You can use this to move through a menu quickly.

You can continue using the arrow keys for moving the highlight to nearby items.

## The SmartKeys and Softkeys

The SmartKeys are at the bottom of the Main screen. They give you fast access to selected functions. A selection of SmartKeys are made for your monitor at the factory, but these can be changed by your biomedical engineering staff or Philips representative.

You can get access to other SmartKeys by pressing the TouchStrip beneath the ◀ and the ▶ symbols.

In certain circumstances, such as when you are admitting a patient or examining trend data, the SmartKeys are replaced by softkeys.

To highlight a SmartKey or a softkey, lightly touch the TouchStrip beneath it.

To select a SmartKey or a softkey, press harder on the TouchStrip beneath it.

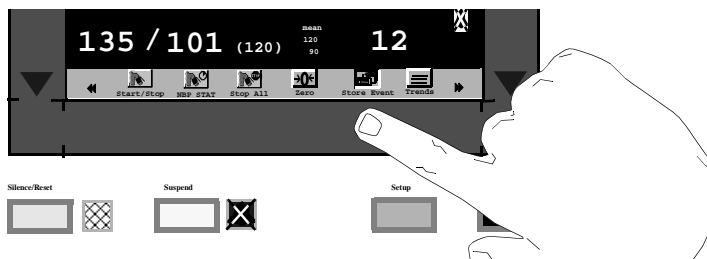



## The Corner of the TouchStrip

1. If you have a window open on the screen, the left and right lower corners of the TouchStrip activate the function displayed on the bottom line of that window.

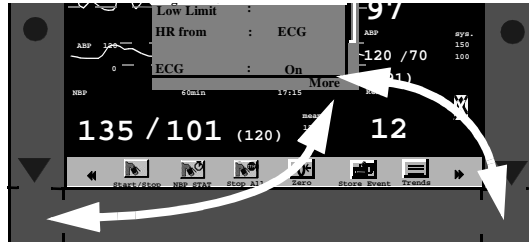

If the contents of a window is more than 8 lines long, the corners activate the **More** to page down.

If you have paged down to the very bottom of a menu, the corners activate the **Exit**, to close the menu.

## Setting Up a Measurement

- Step 1.** Highlight a measurement by lightly touching the TouchStrip beside the numeric for that measurement. If there are two numerics next to each other, move your finger on the TouchStrip until the one you want is highlighted.

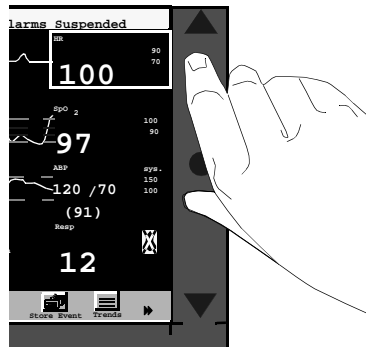

- Step 2.** Select the highlighted measurement by pressing the TouchStrip. The menu for that measurement is displayed.

**Step 3.** Highlight the setting you want using the up or down arrow on the TouchStrip, or by gliding your finger along the TouchStrip.

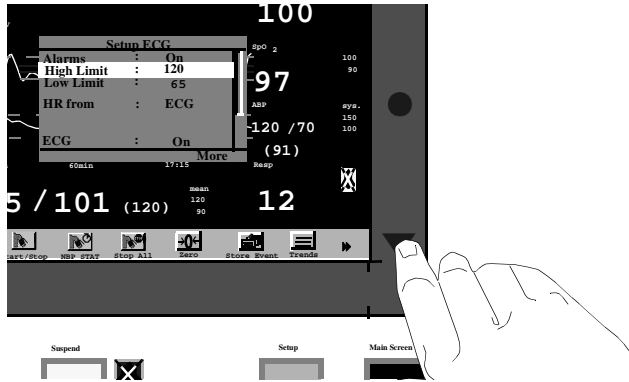

**Step 4.** Select the setting by pressing the dot on the TouchStrip

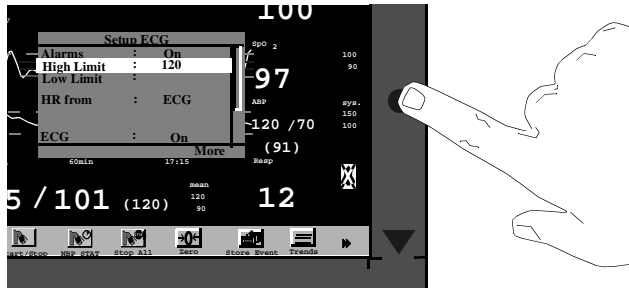

If there are a number of possible settings, these will be displayed and you highlight the setting you want, and then select it.

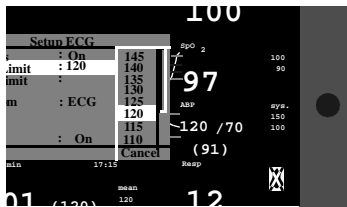

If there are only two possible settings, selecting the setting will change the setting.

If you want to cancel editing without changing the setting, press the bottom right or left hand corner to cancel.

**Step 5.** Continue editing settings until you have set up the measurement

**Step 6.** Press the blue **Main Screen** key, press the bottom right or left hand corner to exit, or move the highlight to “Exit” at the very bottom of the menu then press the TouchStrip.

## Setting Up a Wave

**Step 1.** Highlight the wave by lightly touching the TouchStrip beside it

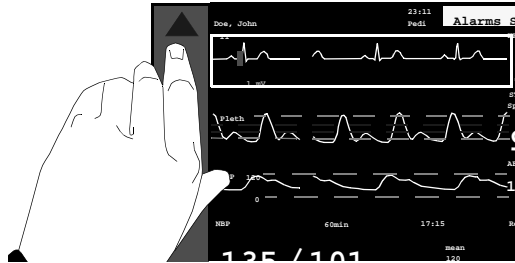

Select the highlighted wave by pressing the TouchStrip. The list of waves are displayed.

**Step 2.** Press on the TouchStrip again to get the wave setup.

**Step 3.** Highlight the setting you want to edit by touching or holding your finger on the up or down arrow on the TouchStrip, or by gliding your finger along the TouchStrip.

**Step 4.** Select the setting by pressing the dot on the TouchStrip.

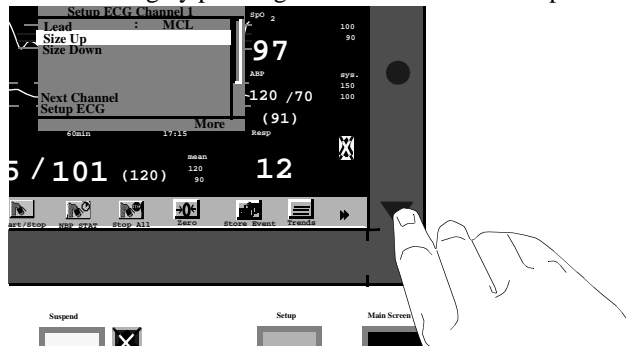

If the setting has a number of possible settings, these will be displayed and you highlight the setting you want, and then select it.

If the setting only has a two possible settings, selecting the setting will change the setting.

If you want to cancel editing without changing the setting of a setting, press the bottom right or left hand corner to cancel.

**Step 5.** Continue editing settings until you have set up the wave.

**Step 6.** Press the blue **Main Screen** key, press the bottom right or left hand corner to exit, or move the highlight to “Exit” at the very bottom of the menu then press the TouchStrip.

---

## Basic Setup

### Selecting a Wave for the Screen

**Step 1.** Highlight the position on the screen where you want the wave to be placed by touching the TouchStrip beside the position.



**Step 2.** Select the position by pressing the TouchStrip.  
The available waves for the position are displayed (the wave is only available if the measurement is switched on).

**Step 3.** Highlight the wave you want using the up or down arrow on the TouchStrip, or by gliding your finger along the TouchStrip.

If you select **Blank**, the position will be kept clear (unless an ECG wave cascades into the position).

(If you do not assign a wave, and do not mark the position Blank, then one will be assigned automatically when you plug in a transducer that produces a wave.)

**Step 4.** Select the wave by pressing the TouchStrip.

If you want to exit editing without changing the wave, press the **Main Screen** key.

You can also assign a wave to a position in the setup menu. Press the **Setup** key then select **Waves**.

## Setting the Waves Speed

Changing the Waves Speed does not affect the speed of respiratory waves. You must set the speed of the respiratory waves separately (see “Changing the Speed of the Respiration Wave” on page 184).

To set the wave speeds for all the waves on the screen,

**Step 1.** Press the **Setup** key.

**Step 2.** Move the highlight to “**Speed**”.

This will set the speed for the waves except the respiration waves.

**Step 3.** Press on the TouchStrip.

**Step 4.** Select the appropriate setting.

**Step 5.** Select “**Resp Speed**”.

This will set the speed of the respiration waves.

**Step 6.** Select the appropriate setting.

**Step 7.** Exit the Setup menu.

## Switching Measurements On or Off

To switch a particular measurement on or off, use the setup for that measurement (see “Setting Up a Measurement” on page 41).

## Checking and Changing the Alarm Limits

To check or change the alarm limits for a particular measurement, use the setup for that measurement (see “Setting Up a Measurement” on page 41).

---

### Caution

---

Make sure that the printer or recorder is connected and switched on before you start printing or recording.

---

## Printing a Copy of the Current Measurements

To print a copy of the current measurements to a connected printer, press the **Print Screen** SmartKey (you may have to press ◀ or ▶ to find this SmartKey, if it is configured).



## Recording Strips Locally

Two types of local recording can be made: a real-time recording and a delayed recording.

A real-time recording is started by pressing the **Local Record** SmartKey. When a recording is running, you can stop it by pressing the key again.



Local  
Record

A delayed recording can be started by pressing the **Local Delayed** SmartKey. Pressing the key again will extend the recording.



Local  
Delayed

---

### Warning

---

## Adjusting the Volume

If you switch the Alarm Volume off, you will not get any audible indication of alarm conditions.

---

**Step 1.** Highlight the **QRS Volume** SmartKey to see the current setting for the volume of the QRS tone (you may have to press ◀ or ▶ to find this SmartKey, if it is configured).



**Step 2.** Press the **QRS Volume** SmartKey repeatedly to select the volume of the QRS tone,.

The volume can be set from 1 to 10 (or 0, which is off, if this has not been

disabled). The current setting for the volume is displayed on the prompt line as you press the SmartKey or touch it for 1/2 second.

**Step 3.** Highlight the **Alarm Volume** SmartKey to see the current setting for the volume of the alarm tone (you may have to press ◀ or ▶ to find this SmartKey, if it is configured).



**Step 4.** Press the **Alarm Volume** SmartKey repeatedly to select the volume of the Alarm tone..

The volume can be set from 1 to 10 (or 0, which is off, if this has not been disabled). The current setting for the volume is displayed on the prompt line as you press the SmartKey or touch it for 1/2 second.

OR

**Step 1.** Press the **Setup** key.

**Step 2.** If you want to change the setting for the QRS volume,

- a. Move the highlight to “**QRS Volume**”.
- b. Press on the TouchStrip.
- c. Select the level for the QRS volume.

**Step 3.** If you want to change the setting for the alarm volume,

- a. Move the highlight to “**Alarm Volume**”.
- b. Press on the TouchStrip.
- c. Select the appropriate setting for the alarm volume.

**Step 4.** Exit the Setup menu.

## Adjusting the Screen Brightness

**Step 1.** To change the Brightness of the screen, press the **Brightness** SmartKey (you may have to press ◀ or ▶ to find this SmartKey, if it is configured).



OR

- a. Press the **Setup** key
- b. Move the highlight to “**Brightness**”.

**Step 2.** Press on the TouchStrip.

**Step 3.** Select the appropriate setting for the screen brightness. 10 is the brightest, 1 the least bright and **Optimum** allows the monitor to adapt the brightness automatically.

**Step 4.** Exit the Setup menu.

The brightness of the screen is reduced automatically when you power the monitor from the battery, if it has been configured by your biomedical engineer.

## Setting the Date and Time

---

---

### Warning

---

---

Changing the date or time will affect the storage of trends and events

---

---

- Step 1.** Highlight the area at the top left of the screen by touching the TouchStrip beside it and select it by pressing the TouchStrip.  
OR  
Press the **Setup** key.
- Step 2.** Move the highlight to “**Date, Time**”.
- Step 3.** Highlight, then select the appropriate setting for the Year, Month, Day, Hour (in 24 hour format, only) and Minute as necessary.
- Step 4.** Highlight and select **Store Date, Time** to change the date and time.

## Recalling a QuickSet

The default sets that are set in the factory for the monitor are described in “Selecting a QuickSet” on page 97. A QuickSet is broadly equivalent to a Profile in the IntelliVue family of patient monitors.

*Note*—If you change the QuickSet, any currently active automatic NBP measurement will be stopped.

- Step 1.** To get into the QuickSets menu, press the **QuickSets** SmartKey (you may have to press ◀ or ▶ to find this SmartKey, if it is configured).

















- OR
- a. Highlight the area at the top left of the screen (where the current QuickSet is displayed) by touching the TouchStrip beside it and select it by pressing the TouchStrip.
- OR
- b. Press the **Setup** key.
  - c. Move the highlight to “**QuickSets**”.

- Step 2.** Press on the TouchStrip.  
The current QuickSet is highlighted, and displayed with an asterisk (\*) beside it. It is also displayed at the top left of the screen.











- Step 3.** Highlight the setting you want, and press on the TouchStrip to select it.
- Step 4.** Exit the Setup menu.



## Summary of the SmartKeys

	See “Printing a Copy of the Current Measurements” on page 46
	See “Adjusting the Screen Brightness” on page 47.
	See page 47 or “Changing The Volume of the Alarm Chime” on page 59.
	See “Selecting the Patient Identification Menu” on page 94.
	See page 48 or “Selecting a QuickSet” on page 97.
	See page 46 or “Selecting the Volume of the Tone” on page 133.
	See “Making a Single NBP Measurement” on page 193 and “Making Automatic NBP Measurements” on page 194.
	See “Making stat NBP Measurements” on page 193.
	“Making a Single NBP Measurement” on page 193 and “Making Automatic NBP Measurements” on page 194.
	See “Using the NBP Cuff to Occlude Blood Vessels” on page 195.
	See “Zeroing the Transducer” on page 207.
	See “Viewing the Trend” on page 272.
	See “Storing an Event Manually” on page 274.
	See “Reviewing Events” on page 275.
	See “Setting Automatic Alarm Limits” on page 59.

## Summary of the SmartKeys

	See “Setting Automatic Alarm Limits” on page 59.
	See “Reviewing Beat Labels” on page 161.
	Switches on Standby mode.
	See “Relearning Arrhythmia” on page 161.
	See “Changing the Size of the ECG Wave” on page 142.
 <b>Record</b>	See “Recording and Printing at the Information Center” on page 110.
 <b>Delayed Rec.</b>	See “Recording and Printing at the Information Center” on page 110.
 <b>Local Record</b>	See “Recording Strips Locally” on page 46.
 <b>Local Delayed</b>	See “Recording Strips Locally” on page 46.
	See “Viewing Information for Other Patients from the Bed-side” on page 115.

# Dealing with Alarms

This chapter is about recognizing alarms, responding to alarms, setting up alarms, and recording alarms.

A list of the physiological patient alarms, and the technical alarms (INOPs) is given at the end of the chapter.

- Recognizing Alarms . . . . . 52
- Dealing with Alarms . . . . . 54
- Silencing Alarms. . . . . 57
- Suspending Alarms . . . . . 57
- Checking and Changing the Alarm Limits . . . . . 58
- Changing The Volume of the Alarm Chime. . . . . 59
- Alarm Recording. . . . . 60
- Patient Alarm Messages . . . . . 61
- Technical Alarm Messages (INOPs). . . . . 76

---

## Recommendation for Alarm Configuration

When using **Arrhythmia Analysis** it is recommended that both visual and audible alarms are set to latching, or at least the visual red alarms.

During **attended monitoring** (for example in the Operating Room), latching for visual and audible alarms may be configured to OFF.

During **unattended monitoring**, it is recommended that both visual and audible alarms are set to latching for red and yellow alarms.

See “Latching and Non-Latching Alarms” on page 54 for a description of latching and non-latching behavior.

See “Changing How Alarms Behave Until Silenced” on page 370, for how to make VisLatching and AudLatching settings.

## Recognizing Alarms

### Patient Alarms

There are three types of patient alarm:

- A Red Alarm indicates a high priority patient alarm such as a life threatening situation (for example, asystole).
- A Yellow Alarm indicates a lower priority patient alarm, (for example, a blood pressure limit alarm).
- A Yellow Arrhythmia Alarm is specific to arrhythmia-related patient conditions (for example, the ventricular bigeminy alarm).

Patient alarms are indicated by visual indicators and a sound.

The sound indicators for a patient alarm are as follows (if the volume has not been turned down. See “Changing The Volume of the Alarm Chime” on page 59):

- If there is a Red Alarm, the sound is higher pitched and repeated once a second.
- If there is a Yellow Alarm (and no Red Alarms), the sound is lower pitched and repeated every two seconds.
- If there is a Yellow Arrhythmia Alarm, the sound is at the same pitch as the Yellow alarm but lasts for only 5 seconds.

The visual indicators for a patient alarm are:

- A message at the top right of the screen. Only the highest priority alarm for a measurement is shown. If more than one measurement is in an alarm condition, the message will change every 2 seconds, and it will have an arrow (↑) at the side. [See “Reviewing Alarms” on following page for how to see all current messages.]  
For a red alarm, the message starts with three stars (\*\*\*)  
For all yellow alarms, the message starts with two stars (\*\*)
- The numeric of the measurement in alarm blinks.
- A red or yellow lamp on the front panel blinks.
- If the alarm is due to the value for a measurement crossing an alarm limit, and if this limit is displayed on the screen, then that alarm limit is highlighted.

- The alarm condition is also indicated on any device connected to the Nurse Call Relay at the rear of the monitor, if the monitor is so configured (see “Changing the Conditions for the Nurse Call Relay”).

## Technical Alarms

Technical alarms (referred to as INOPs) indicate that the monitor cannot measure or detect alarm conditions reliably. They are signalled by a message at the top left of the screen (only the highest priority technical alarm is displayed for a measurement). If more than one measurement has a technical alarm, the message will change every 2 seconds, and it will have an arrow (↑) at the side. Technical alarm conditions which cause an interruption of valid data and alarm detection (for example, LEADS OFF) have an audible indicator (a different sound at the same pitch as the yellow patient alarm, and repeated every 2 seconds).

Technical alarms without this audible indicator indicate that there might be a problem with the validity of the data.

---

## Reviewing Alarms

If more than one measurement is in an alarm condition, the message shown at the top right of the screen will change every two seconds and it will have an arrow (↑) at the side. To see a list of all current alarm messages, press on the TouchStrip next to the alarm message.

To review all recent alarms, press the softkey **Review Alarms**. A window with all the latest alarms is displayed, including any changes in the Alarms On/Off or Alarms Silenced status.

If there is more than one alarm active within a channel, only the one with the highest priority will be displayed in the corresponding text field, but all affected numerics blink if alarms are active.

## Dealing with Alarms

### Latching and Non-Latching Alarms

Alarm latching behavior for audible and visual alarms can be set separately. In the alarm setup you can choose between three possible settings for Visual Latching (Red&Yellow, Red Only, OFF) and up to three choices for Audible Latching:

- **Latching** for Red and Yellow alarms (AudLatching or VisLatching set to <Red&Yell> in the alarm setup).
- **Latching** for Red alarms only (set to <Red Only> in the alarm setup).
- **Non-latching** for all alarms (AudLatching or VisLatching set to <Off> in the alarm setup).

*Note*—VisLatching can never be set for fewer alarms than AudLatching (this means that it is e.g. not possible to set VisLatching to <Off> and at the same time AudLatching to <RedOnly>)

How to set the latching setting for the alarm is described in “Changing How Alarms Behave Until Silenced” on page 370.

The following tables describe the alarm behaviors for parameter and arrhythmia alarms:

Red & Yellow Parameter Alarms		Non-latching alarms	Latching alarms	Visual latching Audible non-latching
<b>Silence/Reset</b> has NOT been activated.  Alarm condition is present  Alarm condition no longer present.	Alarm condition is present	Audible alarm sounds. Visual alarm message shown. Numerics blink.		
	Alarm condition no longer present.	Audible and Visual alarms and blinking numerics <b>automatically</b> reset.	Audible alarm sounds. Visual alarm message shown. Numerics blink.	Visual alarm message shown. Numerics blink. Audible alarm <b>automatically</b> resets.

<b>Red &amp; Yellow Parameter Alarms</b>		<b>Non-latching alarms</b>	<b>Latching alarms</b>	<b>Visual latching Audible non-latching</b>
<b>Silence/Reset</b> has been activated.	Alarm condition is present.	Audible alarm silenced. Audible alarm re-sounds every 1, 2 or 3 minutes if configured.  Visual alarm message shown and numerics blink.		
	Alarm condition no longer present	Audible and Visual alarms and blinking numerics reset.		

<b>Yellow Arrhythmia Alarms</b>		<b>Non-latching alarms</b>	<b>Latching alarms</b>	<b>Visual latching Audible non-latching</b>
<b>Silence/Reset</b> has NOT been activated.	Alarm condition is present	Audible alarm sounds for 5 seconds.  Visual alarm message shown and numeric blinks for at least 3 minutes. Time-out period begins when alarm activated.		
	Alarm condition no longer present.	Visual alarm message disappears and numeric stops blinking after 3 minutes.		
<b>Silence/Reset</b> has been activated.	Alarm condition is present.	Visual alarm message shown and numeric blinks until condition clears. Time-out period continues.		
	Alarm condition no longer present.	Visual alarm message disappears and numeric stops blinking.		

## Dealing with Alarms

<b>Red Arrhythmia Alarms</b>		<b>Non-latching alarms</b>	<b>Latching alarms</b>	<b>Visual latching Audible non-latching</b>
<b>Silence/ Reset</b> has NOT been activated.	Alarm condition is present	Audible alarm sounds. Visual alarm message shown. Numeric blinks.		
	Alarm condition no longer present.	Audible and Visual alarms and blinking numerics <b>automatically</b> reset. <sup>a</sup>	Audible alarm sounds. Visual alarm message shown. Numerics blink.	Visual alarm message shown. Numerics blink.  Audible alarm <b>automatically</b> resets. <sup>b</sup>
<b>Silence/ Reset</b> has been activated.	Alarm condition is present.	Audible alarm silenced. Audible alarm re-sounds every 1, 2 or 3 minutes if configured. Reminder can be configured to either remind (short reminder tone) or to ReAlarm (treated as new alarm)  Visual alarm message shown and numerics blink.		
	Alarm condition no longer present.	Audible and Visual alarms and blinking numerics reset.		

- a. For episodic alarms such as V-Tach or pause alarms, this may result in a very short alarm sound and visual message.
- b. For episodic alarms such as V-Tach or pause alarms, this may result in a very short alarm sound.



---

## Silencing Alarms

To stop the audible alarm indications, press the **Silence/Reset** key on the Measurement Server (if it is enabled), or on the Monitor. If the patient is centrally monitored, an alarm can also be silenced from the Philips Information center (when Remote Silence is enabled, see “Configuring the Alarms” on page 369).

The visible alarm indicators will stop too, if the alarm conditions no longer exist.

---

Note	Silencing an INOP which results from a disconnected transducer will normally cause the associated measurement to be switched off. When such an INOP is silenced from the Information Center, the measurement will <b>not</b> be switched off.
------	---

---



---

## Suspending Alarms

To stop the monitor indicating alarms, press the **Suspend** key.

While the alarms are suspended the red light with a crossed bell beside the **Suspend** key stays on, and the message **Alarms Suspended** is displayed at the upper right corner of the screen.



**The alarms can be suspended for 1 minute, 2 minutes, 3 minutes or infinitely. If the alarms have been suspended for 1, 2 or 3 minutes, the remaining time is displayed with the Alarms Suspd message. (See “Changing How Long Alarms Stay Suspended” on page 369 about configuring a restart period)**

**While alarms are suspended, no alarm messages are shown, INOPs are shown, but there is no sound, and the Nurse Call relay is not active.**

## Restarting Suspended Alarms

- If the monitor has been configured to only stay suspended for 1, 2 or 3 minutes, the monitor will start indicating alarms again after the suspension period, or as soon as you press the **Suspend** key a second time.
- If the monitor has been configured to stay suspended infinitely, you will have to press the **Suspend** key again to restart the monitor checking for alarm conditions.

---

## Checking and Changing the Alarm Limits

There are two ways to set alarm limits.

You can set individual limits for each measurement as described in the “Changing the Alarms” section in each of the measurement chapters.

You can also use the **AutoLimits** function of the monitor which sets limits for you based on the trended measurement values for each measurement. The limits are set when you use one of the **AutoLimits** SmartKeys (see “Setting Automatic Alarm Limits” below) and will remain unchanged until you set them again or change them manually. There are two SmartKeys:

<b>Limits Narrow</b>	Sets limits close to the currently measured values for situations where it is critical for you to be informed about small changes in the vital signs
<b>Limits Wide</b>	Sets limits further away from the currently measured values for situations where small changes are not so critical.

The measurements to be affected by the **AutoLimits** setting can be configured in the password-protected **Config** operating mode.

## Setting Automatic Alarm Limits

- Step 1.** Press the **Limits Wide** or **Limits Narrow** SmartKey (you may have to press ◀ or ▶ to find these SmartKeys if they are configured).
- Step 2.** Select the appropriate setting: **All** for AutoLimits on all measurements on the list or a specific measurement from the list for AutoLimits on that measurement.

### Caution

When AutoLimits have been set, you must check the limits to ensure that they are appropriate for your individual patient and their clinical condition. Most limits can be seen next to the appropriate waves or numerics on the Main Screen. If necessary, individual limits can be adjusted as described in the “Changing the Alarms” section in each of the measurement chapters.

## Changing The Volume of the Alarm Chime

### Warning

If you switch the Alarm Volume off, you will not get any audible indication of alarm conditions.

- Step 1.** Highlight the **Alarm Volume** SmartKey to see the current setting for the volume of the alarm tone (you may have to press ◀ or ▶ to find this SmartKey, if it is configured). 
- Step 2.** Press the **Alarm Volume** SmartKey repeatedly to select the volume of the Alarm tone,.  
The volume can be set from 1 to 10 (or 0, which is off, if this has not been disabled). The current setting for the volume is displayed on the prompt line as you press the SmartKey.

OR

- Step 1.** Press the **Setup** key.
- Step 2.** Move the highlight to “**Alarm Volume**”.
- Step 3.** Press on the TouchStrip.
- Step 4.** Select the level for the alarm volume.
- Step 5.** Exit the Setup menu.

---

## Alarm Recording

If a local recorder is connected to the monitor via the optional serial interface, or if the monitor is connected to a network, you can make alarm recordings. In configuration mode, you can select the local recorder or the Information Center, or both, to record alarms (See “Selecting Where to Make Alarm Recordings” on page 373). If one of the configured alarms occurs, a recording for that alarm is requested from the Information Center or started at the local recorder.

## Patient Alarm Messages

The alarms are listed alphabetically in the table (irrespective of their priority).

Technical alarms are listed in the section “Technical Alarm Messages (INOPs)” on page 76.

### Physiological Alarms

Alarm Message	Measurement	Condition	Visual Indication	Audible Indication
<b>*** ABP DISCONNECT</b>	PRESS	Mean pressure is continuously less than 10mmHg (1.3kPa)	ABP numeric blinks, Red alarm lamp	A chime every second.
<b>** ABP HIGH</b>	PRESS	Pressure above high alarm limit The <b>s</b> , <b>d</b> , or <b>m</b> after the label indicates whether it is the systolic, diastolic or mean pressure that has crossed the limit.	ABP numeric blinks, Yellow alarm lamp. High limit is highlighted only if the pressure is configured for single alarming <sup>a</sup> .	A chime every 2 seconds.
<b>** ABP LOW</b>	PRESS	Pressure below low alarm limit The <b>s</b> , <b>d</b> , or <b>m</b> after the label indicates whether it is the systolic, diastolic or mean pressure that has crossed the limit.	ABP numeric blinks, Yellow alarm lamp. Low limit is highlighted only if the pressure is configured for single alarming <sup>a</sup> .	A chime every 2 seconds.
<b>*** APNEA</b>	RESP	The respiration has stopped for longer than the preset apnea time	RR numeric blinks, Red alarm lamp	A chime every second.
<b>*** APNEA</b>	CO <sub>2</sub> AwRR	The respiration has stopped for longer than the preset apnea time	AwRR numeric blinks, Red alarm lamp	A chime every second.

**Physiological Alarms**

<b>Alarm Message</b>	<b>Measurement</b>	<b>Condition</b>	<b>Visual Indication</b>	<b>Audible Indication</b>
<b>***ART DISCONNECT</b>	PRESS	Mean pressure is continuously less than 10mmHg (1.3kPa)	ART numeric blinks, Red alarm lamp	A chime every second.
<b>** ART HIGH</b>	PRESS	Pressure above high alarm limit The <b>s</b> , <b>d</b> , or <b>m</b> after the label indicates whether it is the systolic, diastolic or mean pressure that has crossed the limit.	ART numeric blinks Yellow alarm lamp. High limit is highlighted only if the pressure is configured for single alarming <sup>a</sup> .	A chime every 2 seconds.
<b>** ART LOW</b>	PRESS	Pressure below low alarm limit The <b>s</b> , <b>d</b> , or <b>m</b> after the label indicates whether it is the systolic, diastolic or mean pressure that has crossed the limit.	ART numeric blinks Yellow alarm lamp. Low limit is highlighted only if the pressure is configured for single alarming <sup>a</sup> .	A chime every 2 seconds.
<b>***Ao DISCONNECT</b>	PRESS	Mean pressure is continuously less than 10mmHg (1.3kPa)	Ao numeric blinks, Red alarm lamp	A chime every second.
<b>** Ao HIGH</b>	PRESS	Pressure above high alarm limit The <b>s</b> , <b>d</b> , or <b>m</b> after the label indicates whether it is the systolic, diastolic or mean pressure that has crossed the limit.	Ao numeric blinks Yellow alarm lamp. High limit is highlighted only if the pressure is configured for single alarming <sup>a</sup> .	A chime every 2 seconds.

## Physiological Alarms

Alarm Message	Measurement	Condition	Visual Indication	Audible Indication
<b>** Ao LOW</b>	PRESS	Pressure below low alarm limit The <b>s</b> , <b>d</b> , or <b>m</b> after the label indicates whether it is the systolic, diastolic or mean pressure that has crossed the limit.	Ao numeric blinks and Yellow alarm lamp. Low limit is highlighted only if the pressure is configured for single alarming <sup>a</sup> .	A chime every 2 seconds.
<b>*** ASYSTOLE</b>	ECG	No QRS complex detected for a period greater than the set asystole threshold.	HR numeric blinks, Red alarm lamp	A chime every second.
<b>** AWRR HIGH</b>	CO <sub>2</sub> AwRR	The airway respiration rate has exceeded the high alarm limit	AwRR numeric blinks and high limit is highlighted, Yellow alarm lamp.	A chime every 2 seconds.
<b>** AWRR LOW</b>	CO <sub>2</sub> AwRR	The airway respiration rate has dropped below the low alarm limit	AwRR numeric blinks and low limit is highlighted Yellow alarm lamp	A chime every 2 seconds
<b>** CVP HIGH</b>	PRESS	Pressure above high alarm limit The <b>s</b> , <b>d</b> , or <b>m</b> after the label indicates whether it is the systolic, diastolic or mean pressure that has crossed the limit.	CVP numeric blinks Yellow alarm lamp High limit is highlighted only if the pressure is configured for single alarming <sup>a</sup>	A chime every 2 seconds.

**Physiological Alarms**

<b>Alarm Message</b>	<b>Measurement</b>	<b>Condition</b>	<b>Visual Indication</b>	<b>Audible Indication</b>
<b>** CVP LOW</b>	PRESS	Pressure below low alarm limit The <b>s</b> , <b>d</b> , or <b>m</b> after the label indicates whether it is the systolic, diastolic or mean pressure that has crossed the limit.	CVP numeric blinks Yellow alarm lamp. Low limit is highlighted only if the pressure is configured for single alarming <sup>a</sup> .	A chime every 2 seconds.
<b>*** DESAT</b>	SpO <sub>2</sub>	The SpO <sub>2</sub> value has fallen below the desaturation alarm limit.	Numeric flashes, Red alarm lamp	Alarm tone
<b>**EtCO<sub>2</sub> LOW</b>	msCO <sub>2</sub> / ssCO <sub>2</sub>	EtCO <sub>2</sub> has dropped below the selected low limit.	EtCO <sub>2</sub> numeric blinks and low limit is highlighted, Yellow alarm lamp	A chime every 2 seconds.
<b>**EtCO<sub>2</sub> HIGH</b>	msCO <sub>2</sub> / ssCO <sub>2</sub>	EtCO <sub>2</sub> has exceeded the selected high limit	EtCO <sub>2</sub> numeric blinks and high limit is highlighted, Yellow alarm lamp	A chime every 2 seconds.
<b>*** EXTREME BRADY</b>	ECG	The heart rate has dropped below the selected bradycardia limit.	HR numeric blinks, Red alarm lamp	A chime every second.
<b>*** EXTREME TACHY</b>	ECG	The heart rate has exceeded the selected tachycardia limit	HR numeric blinks, Red alarm lamp	A chime every second.
<b>** HR HIGH</b>	ECG	The heart rate has exceeded the high alarm limit	HR numeric blinks and high limit is highlighted, Yellow alarm lamp.	A chime every 2 seconds.



## Physiological Alarms

Alarm Message	Measurement	Condition	Visual Indication	Audible Indication
			The sound switches off after 5 seconds if Arrhythmia is ON, and the HR source is ECG	
<b>** HR LOW</b>	ECG	The heart rate has dropped below the low alarm limit	HR numeric blinks and low limit is highlighted, Yellow alarm lamp.	A chime every 2 seconds.
			The sound switches off after 5 seconds if Arrhythmia is on, and the HR source is ECG	
<b>** ICP HIGH</b>	PRESS	Pressure above high alarm limit The <b>s</b> , <b>d</b> , or <b>m</b> after the label indicates whether it is the systolic, diastolic or mean pressure that has crossed the limit.	ICP numeric blinks and high limit is highlighted, if the pressure is configured for single alarming Yellow alarm lamp	A chime every 2 seconds.
<b>** ICP LOW</b>	PRESS	Pressure below low alarm limit The <b>s</b> , <b>d</b> , or <b>m</b> after the label indicates whether it is the systolic, diastolic or mean pressure that has crossed the limit.	ICP numeric blinks and low limit is highlighted, if the pressure is configured for single alarming Yellow alarm lamp	A chime every 2 seconds.
<b>**IMCO2 HIGH</b>	msCO <sub>2</sub> / ssCO <sub>2</sub>	ImCO <sub>2</sub> has exceeded the selected high limit	ImCO <sub>2</sub> blinks and high limit is highlighted, Yellow alarm lamp	A chime every 2 seconds.

**Physiological Alarms**

<b>Alarm Message</b>	<b>Measurement</b>	<b>Condition</b>	<b>Visual Indication</b>	<b>Audible Indication</b>
<b>** IRREGULAR HR<sup>c</sup></b>	ECG/ Arrhythmia	Consistently irregular heart rhythm.	HR numeric blinks, Yellow alarm lamp	A chime every 2 seconds for 5 seconds.
<b>** LAP HIGH</b>	PRESS	Pressure above high alarm limit The <b>s</b> , <b>d</b> , or <b>m</b> after the label indicates whether it is the systolic, diastolic or mean pressure that has crossed the limit.	LAP numeric blinks Yellow alarm lamp High limit is highlighted only if the pressure is configured for single alarming <sup>a</sup>	A chime every 2 seconds.
<b>** LAP LOW</b>	PRESS	Pressure below low alarm limit The <b>s</b> , <b>d</b> , or <b>m</b> after the label indicates whether it is the systolic, diastolic or mean pressure that has crossed the limit.	LAP numeric blinks and low limit is highlighted, if the pressure is configured for single alarming Yellow alarm lamp	A chime every 2 seconds.
<b>** MISSED BEAT</b>	ECG/ Arrhythmia (enhanced)	If HR is less than 120bpm, then an omitted beat was detected. If HR is greater than 120bpm then there was no beat for 1 second.	Numeric flashes, Yellow alarm lamp	A chime every 2 seconds for 5 seconds.
<b>** MULTI-FORM PVCs<sup>c</sup></b>	ECG/ Arrhythmia	The occurrence of two different shaped PVCs in the last 300 beats, repeated in the last 60 beats	PVC numeric blinks, Yellow alarm lamp	A chime every 2 seconds for 5 seconds.

## Physiological Alarms

Alarm Message	Measurement	Condition	Visual Indication	Audible Indication
<b>** NBP HIGH</b>	NBP	NBP above the high alarm limit. The <b>s</b> , <b>d</b> , or <b>m</b> after the label indicates whether it is the systolic, diastolic or mean pressure that has crossed the limit.	NBP numeric blinks Yellow alarm lamp. High limit is highlighted only if the pressure is configured for single alarming <sup>a</sup>	A chime every 2 seconds.
<b>** NBP LOW</b>	NBP	NBP below the low alarm limit for. The <b>s</b> , <b>d</b> , or <b>m</b> after the label indicates whether it is the systolic, diastolic or mean pressure that has crossed the limit.	NBP numeric blinks and low limit is highlighted, if the pressure is configured for single alarming Yellow alarm lamp.	A chime every 2 seconds.
<b>** NON-SUSTAIN VT<sup>c</sup></b>	ECG/ Arrhythmia	A short run of PVCs were detected accompanied by a heartrate greater than the ventricular tachycardia limit.	PVC numeric blinks, Yellow alarm lamp	A chime every 2 seconds for 5 seconds.
<b>***P1 DISCONNECT</b>	PRESS	Mean pressure is continuously less than 10mmHg (1.3kPa)	P1 numeric blinks, Red alarm lamp	A chime every second.
<b>** P1 HIGH</b>	PRESS	Pressure above high alarm limit The <b>s</b> , <b>d</b> , or <b>m</b> after the label indicates whether it is the systolic, diastolic or mean pressure that has crossed the limit.	P1 numeric blinks and Yellow alarm lamp. High limit is highlighted only if the pressure is configured for single alarming <sup>a</sup>	A chime every 2 seconds.

**Physiological Alarms**

<b>Alarm Message</b>	<b>Measurement</b>	<b>Condition</b>	<b>Visual Indication</b>	<b>Audible Indication</b>
<b>** P1 LOW</b>	PRESS	Pressure below low alarm limit The <b>s</b> , <b>d</b> , or <b>m</b> after the label indicates whether it is the systolic, diastolic or mean pressure that has crossed the limit.	P1 numeric blinks and Yellow alarm lamp. Low limit is highlighted only if the pressure is configured for single alarming <sup>a</sup> .	A chime every 2 seconds.
<b>** PACER NOT CAPT<sup>b</sup></b>	ECG/ Arrhythmia (Paced patients only)	A missed beat with a pace pulse was detected.	HR numeric blinks, Yellow alarm lamp	A chime every 2 seconds for 5 seconds.
<b>** PACER NT PACING<sup>b</sup></b>	ECG/ Arrhythmia (Paced patients only)	A missed beat without a pace pulse was detected.	HR numeric blinks, Yellow alarm lamp	A chime every 2 seconds for 5 seconds.
<b>** PAIR PVCs<sup>c</sup></b>	ECG/ Arrhythmia	A non-ventricular contraction, followed by two ventricular contractions followed by a non-ventricular contraction has been detected.	PVC numeric blinks, Yellow alarm lamp	A chime every 2 seconds for 5 seconds.
<b>***PAP DISCONNECT</b>	PRESS	Mean pressure is continuously less than 10mmHg (1.3kPa)	PAP numeric blinks, Red alarm lamp	A chime every second.

## Physiological Alarms

Alarm Message	Measurement	Condition	Visual Indication	Audible Indication
<b>** PAP HIGH</b>	PRESS	Pressure above high alarm limit The <b>s</b> , <b>d</b> , or <b>m</b> after the label indicates whether it is the systolic, diastolic or mean pressure that has crossed the limit.	PAP numeric blinks Yellow alarm lamp. High limit is highlighted only if the pressure is configured for single alarming <sup>a</sup>	A chime every 2 seconds.
<b>** PAP LOW</b>	PRESS	Pressure below low alarm limit The <b>s</b> , <b>d</b> , or <b>m</b> after the label indicates whether it is the systolic, diastolic or mean pressure that has crossed the limit.	PAP numeric blinks Yellow alarm lamp. Low limit is highlighted only if the pressure is configured for single alarming <sup>a</sup> .	A chime every 2 seconds.
<b>** PAUSE<sup>c</sup></b>	ECG/ Arrhythmia	No QRS complex detected for a period greater than the set pause threshold.	HR numeric blinks, Yellow alarm lamp	A chime every 2 seconds. for 5 seconds
<b>** PVC/min HIGH<sup>b</sup></b>	ECG/ Arrhythmia	More premature ventricular contractions have been detected in a minute than the limit.	PVC numeric blinks, Yellow alarm lamp	A chime every 2 seconds for 5 seconds.
<b>** PULSE HIGH</b>	PRESS SpO <sub>2</sub>	The pulse rate has exceeded the high alarm limit	Pulse numeric blinks and high limit is highlighted, Yellow alarm lamp.	A chime every 2 seconds.
<b>** PULSE LOW</b>	PRESS SpO <sub>2</sub>	The pulse rate has dropped below the low alarm limit	Pulse numeric blinks and low limit is highlighted, Yellow alarm lamp.	A chime every 2 seconds.

**Physiological Alarms**

<b>Alarm Message</b>	<b>Measurement</b>	<b>Condition</b>	<b>Visual Indication</b>	<b>Audible Indication</b>
<b>** RAP HIGH</b>	PRESS	Pressure above high alarm limit The <b>s</b> , <b>d</b> , or <b>m</b> after the label indicates whether it is the systolic, diastolic or mean pressure that has crossed the limit.	RAP numeric blinks Yellow alarm lamp. High limit is highlighted only if the pressure is configured for single alarming <sup>a</sup>	A chime every 2 seconds.
<b>** RAP LOW</b>	PRESS	Pressure below low alarm limit The <b>s</b> , <b>d</b> , or <b>m</b> after the label indicates whether it is the systolic, diastolic or mean pressure that has crossed the limit.	RAP numeric blinks and low limit is highlighted only if the pressure is configured for single alarming <sup>a</sup> Yellow alarm lamp	A chime every 2 seconds.
<b>** RR HIGH</b>	RESP	The respiration rate has exceeded the high alarm limit	RR numeric blinks and high limit is highlighted, Yellow alarm lamp.	A chime every 2 seconds.
<b>** RR LOW</b>	RESP	The respiration rate has dropped below the low alarm limit	RR numeric blinks and low limit is highlighted, Yellow alarm lamp.	A chime every 2 seconds.
<b>** RUN PVCs HIGH<sup>c</sup></b>	ECG/ Arrhythmia	More than 2 consecutive premature ventricular contractions have been detected.	PVC numeric blinks, Yellow alarm lamp	A chime every 2 seconds for 5 seconds.

## Physiological Alarms

Alarm Message	Measurement	Condition	Visual Indication	Audible Indication
<b>** R-ON-T PVCs<sup>c</sup></b>	ECG/ Arrhythmia	If the heart rate is less than 100bpm, a PVC with R to R interval less than one third of a second and less than one third of the average R to R interval, followed by a compensatory pause. Or two such ventricular contractions without a compensatory pause within 5 minutes.	PVC numeric blinks, Yellow alarm lamp	A chime every 2 seconds for 5 seconds.
<b>** SpO<sub>2</sub> HIGH</b>	SpO <sub>2</sub>	The arterial oxygen saturation has exceeded the high alarm limit	SpO <sub>2</sub> numeric blinks and high limit is highlighted, Yellow alarm lamp.	A chime every 2 seconds.
<b>** SpO<sub>2</sub> LOW</b>	SpO <sub>2</sub>	The arterial oxygen saturation has dropped below the low alarm limit	SpO <sub>2</sub> numeric blinks and low limit is highlighted, Yellow alarm lamp.	A chime every 2 seconds.
<b>** ST&lt;n&gt; HIGH</b>	ECG/ Arrhythmia (Adult patients only)	The ST segment in lead <n> is higher than the limit.	ST numeric blinks, Yellow alarm lamp	A chime every 2 seconds
<b>** ST&lt;n&gt; LOW</b>	ECG/ Arrhythmia (Adult patients only)	The ST segment in lead <n> is lower than the limit.	STnumeric blinks, Yellow alarm lamp	A chime every 2 seconds.

**Physiological Alarms**

<b>Alarm Message</b>	<b>Measurement</b>	<b>Condition</b>	<b>Visual Indication</b>	<b>Audible Indication</b>
<b>** SVT<sup>c</sup></b>	Arrhythmia	A run of supraventricular beats greater than the SVT run limit has been detected and the HR has exceeded the SVT HR limit.	HR numeric blinks, Yellow alarm lamp	A chime every 2 seconds for 5 seconds.
<b>** T1 HIGH</b>	TEMP	The temperature has exceeded the high alarm limit	T1 numeric blinks and high limit is highlighted, Yellow alarm lamp.	A chime every 2 seconds.
<b>**T1 LOW</b>	TEMP	The temperature has dropped below the low alarm limit	T1 numeric blinks and low limit is highlighted, Yellow alarm lamp.	A chime every 2 seconds.
<b>** Tart HIGH</b>	TEMP	The temperature has exceeded the high alarm limit	Tart numeric blinks and high limit is highlighted, Yellow alarm lamp.	A chime every 2 seconds.
<b>**Tart LOW</b>	TEMP	The temperature has dropped below the low alarm limit	Tart numeric blinks and low limit is highlighted, Yellow alarm lamp.	A chime every 2 seconds.
<b>** Tcore HIGH</b>	TEMP	The temperature has exceeded the high alarm limit	Tcore numeric blinks and high limit is highlighted, Yellow alarm lamp.	A chime every 2 seconds.
<b>**Tcore LOW</b>	TEMP	The temperature has dropped below the low alarm limit	Tcore numeric blinks and low limit is highlighted, Yellow alarm lamp.	A chime every 2 seconds.



## Physiological Alarms

Alarm Message	Measurement	Condition	Visual Indication	Audible Indication
<b>** Tesop HIGH</b>	TEMP	The temperature has exceeded the high alarm limit	Tesop numeric blinks and high limit is highlighted, Yellow alarm lamp.	A chime every 2 seconds.
<b>**Tesop LOW</b>	TEMP	The temperature has dropped below the low alarm limit	Tesop numeric blinks and low limit is highlighted, Yellow alarm lamp.	A chime every 2 seconds.
<b>** Tnaso HIGH</b>	TEMP	The temperature has exceeded the high alarm limit	Tnaso numeric blinks and high limit is highlighted, Yellow alarm lamp.	A chime every 2 seconds.
<b>**Tnaso LOW</b>	TEMP	The temperature has dropped below the low alarm limit	Tnaso numeric blinks and low limit is highlighted, Yellow alarm lamp.	A chime every 2 seconds.
<b>** Trect HIGH</b>	TEMP	The temperature has exceeded the high alarm limit	Trect numeric blinks and high limit is highlighted, Yellow alarm lamp.	A chime every 2 seconds.
<b>**Trect LOW</b>	TEMP	The temperature has dropped below the low alarm limit	Trect numeric blinks and low limit is highlighted, Yellow alarm lamp.	A chime every 2 seconds.
<b>** Tskin HIGH</b>	TEMP	The temperature has exceeded the high alarm limit	Tskin numeric blinks and high limit is highlighted, Yellow alarm lamp.	A chime every 2 seconds.

**Physiological Alarms**

<b>Alarm Message</b>	<b>Measurement</b>	<b>Condition</b>	<b>Visual Indication</b>	<b>Audible Indication</b>
<b>**Tskin LOW</b>	TEMP	The temperature has dropped below the low alarm limit	Tskin numeric blinks and low limit is highlighted, Yellow alarm lamp.	A chime every 2 seconds.
<b>** Tven HIGH</b>	TEMP	The temperature has exceeded the high alarm limit	Tven numeric blinks and high limit is highlighted, Yellow alarm lamp.	A chime every 2 seconds.
<b>**Tven LOW</b>	TEMP	The temperature has dropped below the low alarm limit	Tven numeric blinks and low limit is highlighted, Yellow alarm lamp.	A chime every 2 seconds.
<b>***UAP DISCONNECT</b>	PRESS	Mean pressure is continuously less than 10mmHg (1.3kPa)	UAP numeric blinks, Red alarm lamp	A chime every second.
<b>** UAP HIGH</b>	PRESS	Pressure above high alarm limit The <b>s</b> , <b>d</b> , or <b>m</b> after the label indicates whether it is the systolic, diastolic or mean pressure that has crossed the limit.	UAP numeric blinks Yellow alarm lamp. High limit is highlighted only if the pressure is configured for single alarming <sup>a</sup>	A chime every 2 seconds.
<b>** UAP LOW</b>	PRESS	Pressure below low alarm limit The <b>s</b> , <b>d</b> , or <b>m</b> after the label indicates whether it is the systolic, diastolic or mean pressure that has crossed the limit.	UAP numeric blinks Yellow alarm lamp. Low limit is highlighted only if the pressure is configured for single alarming <sup>a</sup> .	A chime every 2 seconds.

## Physiological Alarms

Alarm Message	Measurement	Condition	Visual Indication	Audible Indication
<b>** UVP HIGH</b>	PRESS	Pressure above high alarm limit The <b>s</b> , <b>d</b> , or <b>m</b> after the label indicates whether it is the systolic, diastolic or mean pressure that has crossed the limit.	UVP numeric blinks Yellow alarm lamp. High limit is highlighted only if the pressure is configured for single alarming <sup>a</sup>	A chime every 2 seconds.
<b>** UVP LOW</b>	PRESS	Pressure below low alarm limit The <b>s</b> , <b>d</b> , or <b>m</b> after the label indicates whether it is the systolic, diastolic or mean pressure that has crossed the limit.	UVP numeric blinks Yellow alarm lamp. Low limit is highlighted only if the pressure is configured for single alarming <sup>a</sup> .	A chime every 2 seconds.
<b>** VENT BIGEMINY<sup>c</sup></b>	ECG/ Arrhythmia	A dominant bigeminy rhythm was detected.	PVC numeric blinks, Yellow alarm lamp	A chime every 2 seconds for 5 seconds.
<b>*** VENT FIB/ TACH</b>	ECG	Fibrillatory waveform for 4 consecutive seconds.	HR numeric blinks, Red alarm lamp	A chime every second.
<b>** VENT RHYTHM<sup>c</sup></b>	ECG/ Arrhythmia	A consecutive run of PVCs has been detected accompanied by a rate less than the limit for ventricular tachycardia.	PVC numeric blinks, Yellow alarm lamp	A chime every 2 seconds for 5 seconds.
<b>** VENT TRIGEMINY<sup>c</sup></b>	ECG/ Arrhythmia	A dominant trigeminy rhythm was detected.	PVC numeric blinks, Yellow alarm lamp	A chime every 2 seconds for 5 seconds.

### Physiological Alarms

Alarm Message	Measurement	Condition	Visual Indication	Audible Indication
*** VTACH <sup>b</sup>	ECG/ Arrhythmia	Ventricular tachycardia has been detected	PVC numeric blinks, Red alarm lamp	A chime every second.

- a. If configured for multiple alarms (e.g. s&d&m), e.g. the string 'Sys' will be highlighted if a systolic alarm is active, and likewise 'Dia' for diastolic or 'Mean' when mean pressure alarm is active.
- b. These messages appear with Basic Arrhythmia
- c. These messages only appear with the Enhanced Arrhythmia option

## Technical Alarm Messages (INOPs)

This table lists all of the technical alarm messages (in alphabetic order) that could appear at the top left of the screen. If a status message with yellow text on a blue background appears at the bottom of the screen, check with your biomedical department.

### Technical Alarms (INOPs)

INOP Message	Measurement	What to do.	Visual Indication	Audible Indication
nothing on screen		Contact your biomedical department. (The connector to the screen is disconnected.)		A beep every 2 seconds.
ABP INOPS	PRESS	See P1 INOPS		
ALL ECG ALARMS OFF	ECG/ Arrhythmia	All ECG alarms have been switched off or the HR source is not ECG		
ART INOPS	PRESS	See P1 INOPS		

**Technical Alarms (INOPs)**

<b>INOP Message</b>	<b>Meas- urement</b>	<b>What to do.</b>	<b>Visual Indication</b>	<b>Audible Indication</b>
Ao INOPS	PRESS	See P1 INOPS		
BAD SERVER LINK		You cannot use this combination of Monitor, Measurement Server and cable. Switch off the monitor and contact your biomedical department.		
BAD SERVER LINK plus “Measurement Server Revision not supported” status message in red.		An M3000A Measurement Server with revision A software is connected to an M3046A Monitor with a software revision of B or later. This combination does not allow monitoring.		
BATTERY EMPTY This INOP cannot be suspended or switched off. This INOP repeats every 3 minutes.		Change the battery immediately. It is nearly empty.		A beep every 2 seconds.
BATTERY LOW		Change the Battery. The battery has less than 20 minutes charge left.		A beep every 2 seconds.
BATTERY MALFUNCT.  This INOP cannot be suspended or switched off. This INOP repeats every 3 minutes.		The status of the battery cannot be determined. If this is a new battery, leave the battery in the monitor and wait to see if the INOP clears after a few minutes. If not, or if this is an older battery, change the battery at the first opportunity.	Battery Symbol	A beep every 2 seconds.

**Technical Alarms (INOPs)**

<b>INOP Message</b>	<b>Measurement</b>	<b>What to do.</b>	<b>Visual Indication</b>	<b>Audible Indication</b>
C LEAD OFF	ECG	Check that the chest electrode is in place and securely attached.	HR numeric might display -?- for 10 seconds.	A beep every 2 seconds.
CANNOT ANALYZE ECG	Arrhythmia	Check all leads and review ECG signal quality.		A beep every 2 seconds.
CANNOT ANALYZE ST	ST	Review the ECG signal quality and the placement of the ISO and J points		
CHARGER MALFUNCT.		Contact your biomedical department. (The battery charging hardware or the battery is faulty)	Battery Symbol	
CHECK INPUT DEVICE		Make sure that nothing is pressing on the keys or the TouchStrip of the monitor. If this is not the problem, contact your biomedical department. (The monitor has detected 5 minutes or more of constant user interface operation, or the user interface hardware is faulty).		None

**Technical Alarms (INOPs)**

INOP Message	Measurement	What to do.	Visual Indication	Audible Indication
CHECK STATUS LOG		<p>An error condition occurred on the monitor and information about it has been saved in the Status Log. View this information as described in “Finding Intermittent Status” on page 307. When you have viewed the information, the INOP is cleared.</p> <p><i>Note:</i> Do not clear the status log, as the information may be useful if faults occur which require diagnosis from a service engineer.</p>		A beep every 2 seconds
CO <sub>2</sub> AUTO ZERO	ssCO <sub>2</sub>	Auto Zero is in progress, no action required.	Numeric is displayed with a ? for the first 15 seconds. After 15 seconds the numeric displays -?-	After 15 seconds, a beep every 2 seconds
CO <sub>2</sub> EQUIP MALF	msCO <sub>2</sub> / ssCO <sub>2</sub>	Contact your biomedical department. [Either 1) the CO <sub>2</sub> hardware or firmware in the M3015A Measurement server extension is incompatible with the M3001A Measurement Server or M3046A monitor, or 2) the CO <sub>2</sub> hardware is faulty.]	CO <sub>2</sub> numeric displays -?-	A beep every 2 seconds

**Technical Alarms (INOPs)**

<b>INOP Message</b>	<b>Measur- ement</b>	<b>What to do.</b>	<b>Visual Indication</b>	<b>Audible Indication</b>
CO <sub>2</sub> NO TRANSDUCER	msCO <sub>2</sub>	Make sure the CO <sub>2</sub> transducer is connected. If you silence this INOP the CO <sub>2</sub> measurement will be switched off.	CO <sub>2</sub> numeric displays -?-	A beep every 2 seconds
CO <sub>2</sub> CAL FAILED	msCO <sub>2</sub>	Make sure that the transducer is on the correct cell and that the power has not failed. Repeat the calibration. If the problem persists, call your biomedical department.	CO <sub>2</sub> numeric displays -?-	A beep every 2 seconds
CO <sub>2</sub> CHECK CAL	msCO <sub>2</sub>	Perform an accuracy check (see “Preparing to Measure CO <sub>2</sub> ” on page 247) and, if necessary, recalibrate the transducer.	CO <sub>2</sub> numeric displays -?-	A beep every 2 seconds
CO <sub>2</sub> SENSOR WARMUP	msCO <sub>2</sub> / ssCO <sub>2</sub>	Wait for the sensor to reach operating temperature (INOP disappears).	CO <sub>2</sub> numeric displays -?- for ssCO <sub>2</sub> . CO <sub>2</sub> numeric is displayed with a ? for msCO <sub>2</sub>	A beep every 2 seconds for ssCO <sub>2</sub> . None for msCO <sub>2</sub> .
CO <sub>2</sub> WAIT CAL2	msCO <sub>2</sub>	Start the CAL2 calibration cycle (see “Preparing to Measure CO <sub>2</sub> ” on page 247)	CO <sub>2</sub> numeric displays -?-	None
CO <sub>2</sub> CAL RUNNING	msCO <sub>2</sub>	Wait until calibration is complete.	CO <sub>2</sub> numeric displays -?-	None



**Technical Alarms (INOPs)**

<b>INOP Message</b>	<b>Meas- urement</b>	<b>What to do.</b>	<b>Visual Indication</b>	<b>Audible Indication</b>
CO <sub>2</sub> CAL MODE	msCO <sub>2</sub>	Start calibration, if required, or switch cal mode off.	CO <sub>2</sub> numeric displays instantaneous CO <sub>2</sub> value.	None
CO <sub>2</sub> CHANGE SCALE	msCO <sub>2</sub> / ssCO <sub>2</sub>	Switch to larger scale so that the whole wave can be displayed.	CO <sub>2</sub> wave is clipped	None
CO <sub>2</sub> PURGING	ssCO <sub>2</sub>	The Measurement Extension is purging the Filterline. This occurs when an occlusion is detected in the line or airway adapter. If the occlusion is not removed by purging, the Measurement Extension will go into Standby Mode and a “CO <sub>2</sub> OCCLUSION” INOP will be displayed.	CO <sub>2</sub> numeric is displays -?-	A beep every 2 seconds
CO <sub>2</sub> OVERRANGE	ssCO <sub>2</sub>	The CO <sub>2</sub> value is higher than the measurement range.	CO <sub>2</sub> numeric displays -?-	A beep every 2 seconds
CO <sub>2</sub> OCCLUSION	ssCO <sub>2</sub>	The FilterLine or exhaust tube is blocked to the extent that a measurement sample cannot be taken. Check the FilterLine and exhaust tube, then disconnect and reconnect the FilterLine. If the INOP is still displayed, use a new FilterLine.	CO <sub>2</sub> numeric displays -?-	A beep every 2 seconds

**Technical Alarms (INOPs)**

INOP Message	Measurement	What to do.	Visual Indication	Audible Indication
CO <sub>2</sub> NO TUBING	ssCO <sub>2</sub>	The FilterLine is disconnected, or an incorrect line is attached (only Microstream accessories can be used). If you Silence this INOP, the measurement will be switched off.	CO <sub>2</sub> numeric displays -?-	A beep every 2 seconds
CO <sub>2</sub> UPDATE FW	ssCO <sub>2</sub>	The software in the Measurement Extension does not match the software in the Measurement Server. This is only likely to occur after a repair or upgrade. Contact your biomedical department	CO <sub>2</sub> numeric displays -?-	A beep every 2 seconds
CUFF NOT DEFLATED  This INOP cannot be suspended or switched off.	NBP	Disconnect the cuff from the Measurement Server, or remove from the patient. You can Silence the INOP, but it remains until the next measurement is started. <i>Adult or pediatric patients:</i> The NBP cuff pressure has been greater than 15mmHg (2kPa) for more than 3 minutes. <i>Neonatal patients:</i> The NBP cuff pressure has been greater than 5mmHg (0.7kPa) for more than 1.5 minutes.	NBP numeric displays -?- Prompt message. Cuff deflates.	A beep every 2 seconds.
CVP INOPS	PRESS	See P1 INOPS		
ECG EQUIP MALF	ECG	Contact your biomedical department. [The ECG hardware is faulty.]	HR numeric displays -?-	A beep every 2 seconds.

**Technical Alarms (INOPs)**

<b>INOP Message</b>	<b>Measur- ement</b>	<b>What to do.</b>	<b>Visual Indication</b>	<b>Audible Indication</b>
ECG LEADS OFF	ECG	Make sure that the patient cable is connected, these leads are connected to the electrodes, and the electrodes are attached.	HR numeric displays -?-	A beep every 2 seconds.
ECG NOISY SIGN.	ECG	Remove any possible sources of signal noise (such as power cords) from the area around the cable or the patient. Make sure that the electrodes are placed properly. ECG signal may be saturated or overloaded.	Prompt message.	None
ECG OUT MALFUNCT	ECG	Contact your biomedical department. [The monitor hardware is faulty.]	Prompt message.	A beep every 2 seconds.
ICP INOPS	PRESS	See P1 INOPS		
LA LEAD OFF	ECG	Check that the LA electrode is in place and attached.	HR numeric might display -?- for 10 seconds.	A beep every 2 seconds.
LAP INOPS	PRESS	See P1 INOPS		
LL LEAD OFF	ECG	Check that the LL electrode is in place and attached.	HR numeric might display -?- for 10 seconds.	A beep every 2 seconds.

**Technical Alarms (INOPs)**

INOP Message	Measurement	What to do.	Visual Indication	Audible Indication
MEAS SERV UN-PLUGGED	Monitor	Make sure that the Measurement Server is connected to the monitor.		A beep every 2 seconds.
MEASSERV UNSUPPORTD	Monitor	The Measurement Server is not supported by the monitor. Contact your service personnel.		A beep every 2 seconds.
<p>NBP CUFF OVERPRESS</p> <p>This alarm cannot be suspended or switched off.</p>	NBP	<p>Disconnect the cuff from the Measurement Server, or remove from the patient. Make sure that the rubber tube to the NBP cuff is not kinked. You can Silence the INOP, but it remains until the next measurement is started or the <b>Stop All</b> SmartKey is pressed. This INOP arises when NBP cuff pressure increased above overpressure safety limits.</p>	<p>NBP numeric displays -?- Prompt message. Cuff deflates.</p>	A beep every 2 seconds.
NBP EQUIP MALF	NBP	<p>Make sure that the rubber tube to the NBP cuff, or the cuff itself, is not kinked. Check the tubing and cuff for leakages. If it is NOT kinked and there are no leaks, contact your biomedical department. The NBP hardware is faulty. You can Silence the INOP, but it remains until the next measurement is started or the <b>Stop All</b> SmartKey is pressed.</p>	<p>NBP numeric displays -?- Prompt message.</p>	A beep every 2 seconds.

**Technical Alarms (INOPs)**

<b>INOP Message</b>	<b>Meas- urement</b>	<b>What to do.</b>	<b>Visual Indication</b>	<b>Audible Indication</b>
NBP INTERRUPTED	NBP	<p>Check the tubing and cuff for leakages. Try repeating the measurement.</p> <p>If the INOP occurs repeatedly, contact your biomedical department. You can Silence the INOP, but it remains until the next measurement is started or the <b>Stop All</b> SmartKey is pressed.</p> <p>This INOP arises when the measurement needed longer than the maximum time for inflation, deflation or the total measurement.</p>	NBP numeric displays -?- Prompt message.	A beep every 2 seconds.
NBP MEASURE FAILED	NBP	<p>Check that the patient type on the monitor is correct.</p> <p>Check the condition and suitability of the patient (see “Preparing to Measure NBP” on page 188).</p> <p>Use another cuff to continue measuring.</p> <p>[No measurement could be made.]</p>	NBP numeric displays -?- Prompt message.	A beep every 2 seconds.
NETWORK DISCONN		<p>With a wired network: check that the network cable is connected. With a wireless network: Check that the monitor has not been moved out-of-range of an access point and that no microwave oven or other non-monitoring wireless device is interfering with the monitor.</p>		

**Technical Alarms (INOPs)**

INOP Message	Measurement	What to do.	Visual Indication	Audible Indication
NO CENTRAL MONITORING		<p>Central monitoring has been interrupted. With a wired network: check that the network cable is connected. With a wireless network: Check that the monitor has not been moved out-of-range of an access point and that no microwave oven or other non-monitoring wireless device is interfering with the monitor. This INOP is affected by the configuration of the CentralMon parameter, as described in “Changing Whether the Monitor Should be Connected to the Network” on page 377.</p>		A beep every 2 seconds.
P1 EQUIP MALF	PRESS	<p>Contact your biomedical department. The pressure hardware is faulty.</p>	P1 numeric displays -?-	A beep every 2 seconds.
P1 NO TRANSDUCER	PRESS	<p>Make sure that the pressure transducer is connected to the Measurement Server. If you Silence this INOP, the measurement will be switched off.</p>	P1 numeric displays -?-	A beep every 2 seconds.
P1 NOISY SIGNAL	PRESS	<p>Change the source for the heart rate to Pleth or ECG (see “Selecting the Source for the Heart Rate Numeric” on page 132). <i>Note</i>—This INOP arises when the pulse detector finds a pulse rate above 350bpm.</p>	Pulse numeric displays -?-	A beep every 2 seconds.

**Technical Alarms (INOPs)**

INOP Message	Measurement	What to do.	Visual Indication	Audible Indication
P1 NON-PULSATILE	PRESS	Change the source for the heart rate to Pleth or ECG (see “Selecting the Source for the Heart Rate Numeric” on page 132). <i>Note</i> —This INOP arises when the pulse rate derived from the pressure being measured is less than 25 beats per minute.	Pulse numeric displays -?-	A beep every 2 seconds.
P1 OVERRANGE	PRESS	Make sure that the measurement has been properly prepared and zeroed, and that the transducer is level with the heart (see “Preparing to Measure Pressure” on page 204). If this does not get rid of the message, exchange the transducer. <i>Note</i> —This INOP arises when the pressure measured was greater than 361mmHg or less than -41mmHg, or if the wire to the transducer is broken.	P1 numeric displays -?-	A beep every 2 seconds.
P1 REDUCE SIZE	PRESS	Increase the scale for the pressure wave. (see “Changing the Size of the Pressure Wave” on page 210).	None	None
P1 TRANSDUC MAL	PRESS	Contact your biomedical department. The transducer is faulty.	P1 numeric displays -?-	A beep every 2 seconds.
P1 ZERO + CHECK CAL	PRESS	Perform a zero (see “Zeroing the Transducer” on page 207), and check the calibration of the transducer (see “Calibrating a CPJ840J6 Transducer” on page 214).	P1 numeric displays -?-	None

**Technical Alarms (INOPs)**

<b>INOP Message</b>	<b>Measur- ement</b>	<b>What to do.</b>	<b>Visual Indication</b>	<b>Audible Indication</b>
PAP INOPS	PRESS	See P1 INOPS		
RA LEAD OFF	ECG	Check that the RA electrode is in place and attached.	HR numeric might display -?- for 10 seconds.	A beep every 2 seconds.
RAP INOPS	PRESS	See P1 INOPS		
RESP EQUIP MALF	RESP	Contact your biomedical department. [The RESP hardware is faulty.]	RR numeric displays -?-	A beep every 2 seconds.
RESP ERRATIC	RESP	Make sure that the electrode is making good contact to the skin.	-?- next to RR label.	None
RESP LEADS OFF	RESP	Make sure that the patient cable is connected, these leads are connected to the electrodes, and the electrodes are attached.	RR numeric displays -?-	A beep every 2 seconds.
RL LEAD OFF	ECG	Check that the RL electrode is in place and attached and make sure that your monitor is configured for 1 channel only when using a three electrode set.	HR numeric might display -?- for 10 seconds.	A beep every 2 seconds.
SERVERLINK MALF		Contact your biomedical department. [The hardware for communicating with the Measurement Server is faulty.]		A beep every 2 seconds.



**Technical Alarms (INOPs)**

<b>INOP Message</b>	<b>Meas- urement</b>	<b>What to do.</b>	<b>Visual Indication</b>	<b>Audible Indication</b>
SOME ECG ALARMS OFF	Arrhyth- mia	Additional Yellow Arrhythmia Alarms have been switched off compared with the current Quick Set		
SPEAKER MALFUNCTION		Contact your biomedical department. [The hardware is faulty.]		
SpO <sub>2</sub> EQUIP MALF	SpO <sub>2</sub>	Contact your biomedical department. [The SpO <sub>2</sub> hardware is faulty.]	SpO <sub>2</sub> numeric displays -?-	A beep every 2 seconds.
SpO <sub>2</sub> ERRATIC	SpO <sub>2</sub>	Make sure the SpO <sub>2</sub> transducer is correctly placed. If this does not solve the problem, make sure that the transducer is working.	SpO <sub>2</sub> numeric displays -?-	A beep every 2 seconds.
SpO <sub>2</sub> EXT. UPDATE	SpO <sub>2</sub>	The update period of displayed values is extended due to an NBP measurement on the same limb or an excessively noisy signal.	SpO <sub>2</sub> numeric is displayed with a ?	None
SpO <sub>2</sub> INTERFERENCE	SpO <sub>2</sub>	Cover the SpO <sub>2</sub> transducer so that it does not get as much ambient light. If this does not solve the problem, make sure that the transducer cable is not damaged. [The level of ambient light is so high that the transducer cannot measure the pulse, or the cable is picking up interference.]	SpO <sub>2</sub> numeric displays -?-	A beep every 2 seconds.

**Technical Alarms (INOPs)**

<b>INOP Message</b>	<b>Measur- ement</b>	<b>What to do.</b>	<b>Visual Indication</b>	<b>Audible Indication</b>
SpO <sub>2</sub> LOW PERF	SpO <sub>2</sub>	Accuracy may be compromised due to very low perfusion. Stimulate circulation at sensor site. If INOP persists, change the measurement site.	SpO <sub>2</sub> numeric is displayed with a ?	None
SpO <sub>2</sub> NO TRANSDUCER	SpO <sub>2</sub>	Make sure the SpO <sub>2</sub> transducer is connected. If you Silence this INOP, the measurement will be switched off.	SpO <sub>2</sub> numeric displays -?-	A beep every 2 seconds.
SpO <sub>2</sub> NOISY SIGNAL	SpO <sub>2</sub>	Try to reduce patient movement, or to relieve the cable strain on the transducer (for example, the wrist strap for the finger transducer) [Excessive patient movement or electrical interference are causing irregular pulse patterns.]	SpO <sub>2</sub> numeric displays -?-	A beep every 2 seconds.
SpO <sub>2</sub> NON-PULSATILE	SpO <sub>2</sub>	Try changing the application site of the transducer, or stimulating circulation at the current site. [Pulse is too weak or is not detectable, or the application site is too thin].	SpO <sub>2</sub> numeric displays -?-	A beep every 2 seconds.
SpO <sub>2</sub> TRANSDUC MALF	SpO <sub>2</sub>	Change the SpO <sub>2</sub> transducer as soon as possible. Return the faulty transducer to your biomedical department.	SpO <sub>2</sub> numeric displays -?-	A beep every 2 seconds.
Tart INOPS	TEMP	See T1 INOPS		
Tcore INOPS	TEMP	See T1 INOPS		
Tesop INOPS	TEMP	See T1 INOPS		

**Technical Alarms (INOPs)**

<b>INOP Message</b>	<b>Meas- urement</b>	<b>What to do.</b>	<b>Visual Indication</b>	<b>Audible Indication</b>
T1 EQUIP MALF	TEMP	Contact your biomedical department. [The temperature hardware is faulty.]	T1 numeric displays -?-	A beep every 2 seconds.
T1 NO TRANSDUCER	TEMP	Make sure the TEMP probe is connected to the Measurement Server. If you Silence this INOP, the measurement will be switched off.	T1 numeric displays -?-	A beep every 2 seconds.
T1 OVERRANGE	TEMP	Try changing the application site of the transducer. [The temperature is less than -1°C, or greater than 45°C.]	T1 numeric displays -?-	A beep every 2 seconds.
Tnaso INOPS	TEMP	See T1 INOPS		

## Technical Alarm Messages (INOPs)

### Technical Alarms (INOPs)

<b>INOP Message</b>	<b>Measurement</b>	<b>What to do.</b>	<b>Visual Indication</b>	<b>Audible Indication</b>
Trect INOPS	TEMP	See T1 INOPS		
Tskin INOPS	TEMP	See T1 INOPS		
Tven INOPS	TEMP	See T1 INOPS		
UAP INOPS	PRESS	See P1 INOPS		
UNSUPPORTED LAN		Switch off the monitor and contact your biomedical department.		
UVP INOPS	PRESS	See P1 INOPS		

# Admitting and Discharging Patients

This chapter covers what you need to know to get your patient data onto the monitor, how to transfer it from one monitor to another, and how to delete it.

- Selecting the Patient Identification Menu. . . . .94
- Admitting A New Patient . . . . .95
- Selecting a QuickSet. . . . .97
- Transferring A Patient To Another Monitor. . . . .98
- Discharging a Patient . . . . .103

## Selecting the Patient Identification Menu

Press the **Admit/Dischrg** SmartKey (you may have to press ◀◀ or ▶▶ to find this SmartKey, if it is configured).



OR

- Step 1.** Highlight the patient name at the top left of the screen (the date and time, and the default sets will be highlighted at the same time).
- Step 2.** Scroll down through the list until **Admit, Discharge...** is highlighted.
- Step 3.** Press on the TouchStrip.

OR

- Step 1.** Press the **Setup** key.
- Step 2.** Scroll down through the list until **Admit, Discharge...** is highlighted.
- Step 3.** Press on the TouchStrip.

## Admitting A New Patient

Centrally monitored patients can be admitted at the Information Center, or at the monitor.

### Changing the Patient Identification

In the Patient Identification menu (see “Selecting the Patient Identification Menu” on page 94).

**Step 1.** Press the **Admit Patient** softkey.

**Step 2.** Select the **Last Name** field.

**Step 3.** Enter the patient’s last name

For each letter

- a. Highlight then press the softkey with the letter you want.  
Highlight then press the up/down-arrow softkey for lower case letters and numbers and symbols  
You can backspace through what you have typed using the back arrow(<).
- b. When you have finished entering the name, highlight then press **OK**.  
If you want to exit without changing anything, highlight then press **EX**.

**Step 4.** Repeat the procedure for the **First Name**, **MRN**, and, if necessary, for the additional information (**Notes**).

If the patient is monitored centrally, make sure that you enter all of the mandatory information.

Make sure that the correct patient category and the correct pacemaker setting is selected for the patient.

**Step 5.** When all data is entered, press the **Confirm** softkey to close this window and return to the Patient Identification menu.

If the patient is monitored centrally, and you have missed any of the mandatory information, a message is displayed, the patient remains unadmitted, and the window does not close.

Enter the missing information and press the **Confirm** softkey again.

### Changing the Patient Category

The Patient Category can be changed at the Monitor or at the central.

Make sure that the patient category is correct. The patient category selects which algorithms are used to calculate the numerics.

If the patient category is not correct, then

**Step 6.** Select **Patient Cat.**

**Step 7.** Select the appropriate setting:

Adult	For adult patients.
Pedi	For pediatric patients.
Neo	For neonatal patients.

## Changing the Pacemaker Setting

The pacemaker setting can be **changed** at the Monitor or at the central.

---

---

### Warning

**The pace pulse rejection must be switched on for paced patients. Switching pace pulse rejection off for paced patients may result in pace pulses being counted as regular QRS complexes which could prevent an asystole alarm from being detected.**

---

---

If the pacing status is not correct, then

**Step 8.** Select **Paced.**

**Step 9.** Select the appropriate setting:

Yes	For paced patients.
No	For non-paced patients.

**Step 10.** When you have finished entering all of the patient identification, press the **Main Screen** key.



---

## Selecting a QuickSet

A QuickSet is a group of settings which has been defined and named in the hospital. There are four different QuickSets which can be defined to match four typical monitoring situations on your unit. (For Information on defining Quicksets see “Saving current settings to a Quick Set” on page 351.) By selecting a QuickSet you can do the basic monitor setup in one step and need only make any individual changes needed for a specific patient.

**Step 1.** To get into the QuickSets menu, press the **QuickSets** SmartKey (you may have to press ◀ or ▶ to find this SmartKey, if it is configured).



OR

**Step 1.** Highlight the patient name at the top left of the screen (the date and time, and the QuickSet will be highlighted at the same time).

**Step 2.** Scroll down through the list until **Quick Sets** is highlighted.

**Step 3.** Press on the TouchStrip.

OR

**Step 1.** Press the **Setup** key.

**Step 2.** Scroll down through the list until **Quick Sets** is highlighted.

**Step 3.** Press on the TouchStrip.

*Note*—If you change the QuickSet, any currently active automatic NBP measurement will be stopped.

*Note*—If the new QuickSet has a different patient category, the default set in the Measurement Server will change automatically.

**Step 4.** Select the QuickSet you want from the list.

---

### Warning

**After selecting a Quickset make sure that the patient category and the pacemaker setting are correct for the patient.**

---

*Note*—In addition to the four QuickSets configured by the user, the four factory default are always available in the configuration operating mode (see “How do I get into Configuration Mode?” on page 346). The factory default sets are listed in “Quick Set Configuration List for the Measurements” on page 380 and “Quick Set Configuration List for Monitoring Settings” on page 387.

---

## Transferring A Patient To Another Monitor

---

### Caution

---

Make sure you do not need any of the trend data for the patient before you transfer the patient.

Make sure you have a printout of the patient data before you transfer a patient.

---

---

### Transferring a Centrally Monitored Patient

You can only transfer a patient that is being centrally monitored.

In the Patient Identification menu (see “Selecting the Patient Identification Menu” on page 94).

**Step 1.** Select **Admit/Discharge...** from this menu.

**Step 2.** Press the **Transfer** softkey.

**Step 3.** Press the **Confirm** softkey to confirm that you want to transfer the patient.

The message ‘Patient prepared for transfer’ is shown, the monitor enters ‘transfer mode’ and the Information Center puts the patient in the transfer list.

### Transferring the Patient Without Equipment

If the patient is transferred without the monitor or Measurement Server, the transfer must be completed by re-admitting the patient at the Information Center.

### Transferring the Patient With the M3046A Monitor

If the patient is transferred with the monitor, when the monitor is reconnected, the Information Center detects that it is in ‘transfer mode’, and automatically re-admits the patient from the transfer list.

### Transferring the Patient With the Measurement Server

If the patient is transferred with the Measurement Server, and the Measurement Server is reconnected to a monitor:

**Step 1.** Press the **Continue Meas Serv** softkey.

The Information Center detects that it is in ‘transfer mode’, and automatically re-admits the patient from the transfer list.

For more information on transferring the patient with a MMS, see “Attaching to a New M3046A Monitor...” on page 100

### Aborting a Transfer

If you disconnect the monitor from the network, and want to leave ‘transfer mode’, in the Patient Identification menu (see “Selecting the Patient Identification Menu” on page 94).

**Step 1.** Select **Admit/Discharge...** from this menu.

**Step 2.** Press the **Clear Transfer** softkey.

**Step 3.** Press the **Confirm** softkey to confirm that you want to clear the transfer.

If you have put the monitor into ‘transfer mode’, but in the end do not want to transfer the patient, in the Patient Identification menu (see “Selecting the Patient Identification Menu” on page 94).

**Step 1.** Select **Admit/Discharge...** from this menu.

**Step 2.** Press the **Re-Admit** softkey.

**Step 3.** Press the **Confirm** softkey to confirm that you want to re-admit the patient from the transfer list.

### Transferring the Patient with the Measurement Server

If the patient is centrally monitored, use the procedure described in “Transferring a Centrally Monitored Patient” on page 98.

The M3046A monitor supports data transfer to and from the Philips IntelliVue family (M800xA) of patient monitors via the M3001A Measurement Server. You can remove the Measurement Server from one monitor (M3046A or M800xA) and connect it to another (M3046A or M800xA). Patient data is stored in the Measurement Server and the monitor, and, if the patient is centrally monitored, in the Information Center.

### Disconnecting the Measurement Server

When you disconnect the Measurement Server, and the alarms are not suspended, the M3046A monitor detects this and displays the message **MeasServ UNPLUGGED**, in the top left-hand corner of the screen. Press **Silence/Reset** to clear the message.

**Attaching to  
the Same  
M3046A  
Monitor...**

If the patient data in the monitor and in the M3001A Measurement Server are the same, measuring continues and you do not need to do anything.

**Attaching to a  
New M3046A  
Monitor...**

If your biomedical department has not configured what happens when a M3001A Measurement Server is attached to a new monitor, two sets of names and identifications for that patient are displayed (one from the M3046A monitor and one from the M3001A Measurement Server). You need to make the following choice:

---

**Warning**

---

**After you have made your choice, make sure that the patient type and the paced mode are correct for your patient.**

---

- If you want to use the patient data from the M3001A Measurement Server, press the **Continue Meas Serv** softkey.
- If you want to use the patient data from the M3046A monitor, press the **Continue Monitor** softkey.
- If it is the same patient, but the data does not match, press the **Same Patient** softkey. The patient information from the monitor is used, where it is available.  
The patient identification is displayed, and you can edit it (as described in “Changing the Patient Identification” on page 95).
- If neither set of patient data is correct, press the **New Patient** softkey. The patients in the monitor and measurement server are discharged, and you can admit the new patient (as described in “Admitting A New Patient” on page 95).
- If you do not want to make the choice at the moment, press **Main Screen**.

Until you make the choice, **Patient ???** will be displayed where the patient name is normally displayed, and **? ? ?** is displayed where the patient category is normally displayed. The Paced/Non-Paced symbol will also appear with question marks. The symbol shows the status of the measurement server.

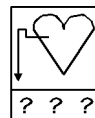

To make the choice, select the patient identification menu and it will be presented again (see “Selecting the Patient Identification Menu” on page 94).

**Attaching to an IntelliVue Patient Monitor**

The behavior of a M3001A Measurement Server transferred from a M3046A to a M800xA patient monitor is the same as if it were transferred to another M3046A.

**Transferring from an IntelliVue to a M3046A Monitor**

The behavior of a M3001A Measurement Server transferred from an IntelliVue patient monitor to a M3046A patient monitor is essentially the same as if it were transferred from another M3046A. However, the IntelliVue family offers additional functionality, and these differences are dealt with in the following way:

<b>IntelliVue-specific data</b>	<b>How M3046A deals with it</b>
Height, Weight, Gender, Date of Birth, Age	Not displayed at all
SpO <sub>2</sub> -left or SpO <sub>2</sub> -right parameter labels	Both are mapped to SpO <sub>2</sub> parameter label. All further trending is done using the SpO <sub>2</sub> label. When reconnected to an IntelliVue monitor, parameter remains as SpO <sub>2</sub> .
General Press/Temp labels ‘P’ or ‘T’	Mapped to ‘P1’ or ‘T1’.
M3001A stores up to eight hours of trend data	The last four hours are displayed.
Trend data from IntelliVue using more than three leads (for example, from an EASI or 12-lead set)	Only trend data from the first three leads are uploaded.
IntelliVue has a different set of colors for numerics or waves.	Unsupported colors are replaced by default fallback colors.

The data that cannot be displayed on a M3046A monitor remains available and can be accessed if the Measurement Server is re-connected to an IntelliVue monitor.

You can connect a 10-electrode lead set, but only the standard five electrodes (RA, LA, RL, LL, and V) are used for monitoring. The rest are automatically ignored.

## Transferring a Patient with the Monitor

If a patient is transferred from one bed to another with the monitor, there will be no change if the patient is not centrally monitored.

If a centrally monitored patient is transferred from one bed to another with the monitor, two sets of names and identifications for that patient are displayed (one from the M3046A monitor and one from the Information Center). You need to make the following choice:

---

### Warning

---

**After you have made your choice, make sure that the patient type and the paced mode are correct for your patient.**

---

---

- If you want to use the patient data from the M3046A Monitor, press the **Continue Monitor** softkey.
- If you want to use the patient data from the Information Center, press the **Continue Central** softkey.
- If it is the same patient, but the data does not match, press the **Same Patient** softkey. The patient information from the Information Center is used, where it is available. The patient identification is displayed, and you can edit it (as described in “Changing the Patient Identification” on page 95).
- If neither set of patient data is correct, press the **New Patient** softkey. The patients in monitor and measurement server are discharged, and you can admit the new patient (as described in “Admitting A New Patient” on page 95).
- If you do not want to make the choice at the moment, press **Main Screen**.

Until you make the choice, **Patient ???** will be displayed where the patient name is normally displayed, and **? ? ?** is displayed where the patient category is normally displayed. The Paced/Non-Paced symbol will also appear with question marks. The symbol shows the status of the measurement server.

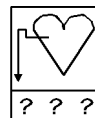

To make the choice, select the patient identification menu and it will be presented again (see “Selecting the Patient Identification Menu” on page 94).

If you attach the measurement server to a monitor that is connected to the network, it could happen that the data does not match for all three.

---

## Discharging a Patient

---

**Caution**            **Make sure you do not need any of the identification, trend, event, or setting data for the patient before you discharge them.**  
**Make sure you have a printout of the patient data before you discharge the patient.**

---

**Warning**            **Discharging a patient resets the patient category and the pacemaker settings.**

---

---

In the Patient Identification menu (see “Selecting the Patient Identification Menu” on page 94).

- Step 1.** Select **Admit/Discharge...** from this menu.
  - Step 2.** Press the **Discharge Patient** softkey.
  - Step 3.** Press the **Confirm** softkey to confirm that you want to delete existing patient data.
- 

**Note**                If a patient is centrally monitored, the patient can be discharged either at the monitor or at the Information Center.  
In this case the patient data is deleted in both the monitor and the Information Center.

---

## Discharging a Patient





## Discharging a Patient

# Communicating with the Information Center

This chapter covers what you need to know about communicating with the Information Center; which data is transmitted, which messages may appear and which differences exist between stand-alone and networked monitors.

- Which Networks are used with the M3046A? . . . . .106
- Interacting with the Information Center . . . . .108
- Configuring the Monitor Label. . . . .112
- Assigning the Monitor to a Care Group . . . . .113
- Troubleshooting the Connection to the Information Center. . . . .113
- Viewing Information for Other Patients from the Bedside. . . . .115

---

## Which Networks are used with the M3046A?

There are two types of communication network which can be used with the monitor: a wired network or a wireless network. In a wired network the data is transferred through a cable and in a wireless network the data is transferred through radio waves.

A network symbol is displayed on the monitor screen:



This symbol indicates a **wired** network. If it appears as shown here, the connection to the Information Center is active. Other versions of this symbol indicating problems are shown in “Troubleshooting the Connection to the Information Center” on page 113



This symbol indicates a **wireless** network. If it appears as shown here, the monitor is in signal range and the connection to the Information Center is active. Other versions of this symbol indicating problems are shown in “Troubleshooting the Connection to the Information Center” on page 113

The wireless symbol is so positioned that it is always visible. This is important as the symbol indicates, by blinking, when you move out of signal range.

Monitors with a wireless network capability have the wireless symbol  on the carrying handle for easy identification.

## **Optimizing Wireless LAN System Performance**

Bedside monitors with a wireless LAN connection have their advantages, however the flexibility the wireless link offers is not without its challenges. The reliability and quality of the wireless signal transmission through the air and hospital walls are governed by a number of variables that can be difficult to control. A wireless LAN connection from a bedside cannot be as dependable as a wired LAN connection.

The effect of low signal strength and interference on the display of the patient information from a wireless bedside at the central station can range from a momentary period to a lengthy period of data loss. Although data loss due to the wireless link may be occurring at the central station, monitoring and alarming continue at the bedside. (This differs from telemetry where monitoring and alarming occur in the central station, so when data loss due to the wireless link occurs, monitoring cannot continue.)

---

### **Warning**

---

**A bedside with a wireless LAN connection should not be used for primary monitoring if occasional loss of data for documentation at the central monitoring station is unacceptable, or if a guarantee of alarm notification at the central station is required.**

---

---

In order to minimize data loss at the central station due to low signal strength and interference, there are several things a hospital should do.

## **Staying in Coverage Area**

Devices called “Access Points” are used to receive the radio signals from the bedsides. A wireless bedside must be within the coverage area of an associated access point for proper operation. When a wireless bedside is taken out of the designated coverage area, data loss at the central station will increase.

---

### **Warning**

---

## **Preventing Interference**

**Various equipment and/or other electrical or medical devices that operate in the 2.4 to 2.48 GHz range could interfere with the radio transmission of important medical data to the central station. Facilities utilizing wireless devices need to manage their use of these devices for safe operation.**

---

---

The effect of interference on the amount of data loss at the central station depends on the strength, type and proximity of the interfering device to the

wireless bedside or access point. Any wireless device operating between 2.4 and 2.48 GHz can cause interference with the monitoring wireless LAN. Likely sources of interference include microwave ovens, other vendors' wireless LANs, wireless telephone headsets, certain cellular phones, handheld computers, and transceiver devices and wireless computer peripherals. In cases where the source of interference is known, removing the device or moving it away from the wireless bedside or access point will improve the system's performance.

Since the wireless LAN used for monitoring emits radio frequencies, it is also possible for it to interfere with other devices. Contact the manufacturers of other equipment used in the vicinity of the monitoring wireless LAN for information on possible susceptibility to these frequencies.

Information on setting the radio frequencies is given in the Service Guide.

It is the hospital's responsibility to keep track of all of the wireless devices in use in the hospital, and manage their use for safe operation.

---

## Interacting with the Information Center

When the monitor is connected to the Information Center, data such as waves, numerics and alarms are automatically sent to the Information Center. There are also some monitor functions which are available remotely at the Information Center.

### **Connecting and Disconnecting from the Network**

When a patient is to be connected to the Information Center, a network connection must be made. How to do this depends on the type of network in use. The possible situations are described below:

1. *Wired network only.*

To connect a patient to the network, plug the LAN connector into the LAN socket on the rear of the monitor.

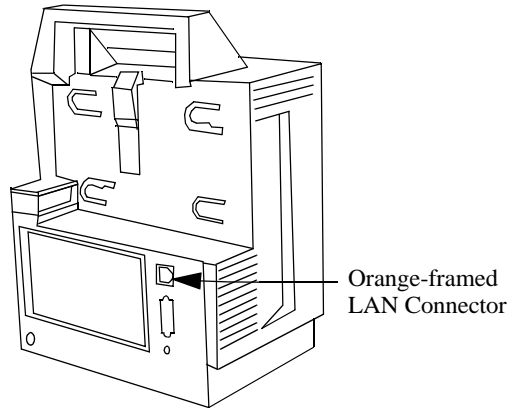

When the patient is to be transported:

- the LAN connector must be pulled out of the LAN socket on the monitor (to remove, press in the lever on the underside of the connector and pull the connector out)
- the monitor power cable (if in use) must be disconnected.
- the recorder interface cable (if in use) must be disconnected from the monitor.

The patient is then no longer centrally monitored.

2. *Wireless network only.*

The monitor automatically makes a connection to the network when the monitor is switched on and is located within the radio signal range.

Making the connection may take up to one minute; during this time the network symbol is shown in inverse video:



When the patient is to be transported, the monitor power cable (if in use) must be disconnected. The patient continues to be centrally monitored as long as the monitor remains within signal range. If the monitor goes out of radio signal range, a “No Central Monitoring” INOP message will appear on the screen and the INOP tone will sound. The network symbol is then

shown as follows:



When the monitor is not in radio signal range when it is powered on, it starts in a non-networked mode. The network symbol is not shown and the patient is not centrally monitored. If the monitor then enters radio signal range while powered on, the monitor automatically makes a connection to the network.

3. *Combined wired and wireless network.*

When a wired LAN connection is available, the patient is connected to the network by inserting the LAN connector as described in 1. above. When the patient is disconnected for transport, the wireless network automatically takes over; this can take up to one minute. The patient continues to be centrally monitored as long as the monitor remains within radio signal range. When the patient returns, the monitor can be reconnected to the wired network as described above and the wired network automatically takes over again.

## **Operating Remotely at the Information Center**

There are four functions of the monitor which are available at the Information Center: silencing alarms, relearning Arrhythmia, admitting patients and switching the monitor to standby. Depending on the configuration of the monitor these functions can be used at either the monitor or the Information Center. (Contact your biomedical department if you would like to have this configuration changed).

For more information on silencing alarms, see “Silencing Alarms” on page 57. For more information on relearning Arrhythmia, see “Relearning Arrhythmia” on page 161. For more information on admitting patients, see “Admitting A New Patient” on page 95.

## **Recording and Printing at the Information Center**

With a wired network, central printers or recorders can be used by the monitor to print reports and record strips.

With a wireless network, central recordings can be made but no central printing is available.



**Printing  
Reports**

To print reports remotely at the Information Center, you need to select the remote printer in the **Setup Printer** window (see “Connecting a Printer” on page 335).

**Recording  
Strips**

There are two types of recording which can be made at the Information Center: a real-time recording and a delayed recording.

A real-time recording is started by pressing the Record SmartKey. When a recording is running, you can stop it by pressing the record SmartKey again.

A delayed recording can be started by pressing the Delayed Recording SmartKey. Pressing the key again will extend the recording. Alarm recordings are a special type of delayed recording automatically triggered by an alarm. You can configure which types of alarm should trigger an alarm recording (see “Changing Which Alarms Trigger a Recording” on page 378).

Any prompt and status messages from the Information Center regarding recording will appear directly above the SmartKeys.

The content and appearance of the recorder strip can only be configured at the Information Center. Refer to the Information Center Instructions for Use for more information.

For local recordings, “Recording Strips Locally” on page 46.

## Configuring the Monitor Label

A monitor label can be entered to uniquely identify your monitor. It is displayed in the upper left corner of the display. When a monitor is connected to a network, the monitor label is replaced by a bed label assigned from the Information Center.

*Note*—In some cases, depending on the AIC bed configuration, the monitor may require a unique label to ensure that it can be assigned and accessed via the network.

For more information on configuring labels see the Installation Guide for the Information Center.

---

### **Warning**

---

**If your monitor is connected to an Information Center, you should not rename the monitor locally (as described in “Naming the Monitor” on page 367) as this can result in you losing the connection to the Information Center.**

---

---

---

## Assigning the Monitor to a Care Group

When a monitor is connected to a wired network, the monitor can be assigned to a Care Group from the Information Center. Each monitor in a Care Group has easy access to the status of the other monitors in the same group. For more information on accessing the status of other monitors see “Viewing Information for Other Patients from the Bedside” on page 115. For more information on assigning monitors to a Care Group see the Installation Guide from the Information Center.

---

## Troubleshooting the Connection to the Information Center



### When Connecting a Monitor to the Network

The following prompt messages can appear when problems occur during connection:

<u>Message</u>	<u>What to do</u>
<b>No Central assigned to this bed</b>	Check the bed assignments at the Information Center and that the monitor label assigned to this monitor has not been changed locally
<b>No Central - duplicate monitor label</b>	Check that the monitor label assigned to this monitor has not been changed locally. Check the assignment at the Information Center.
<b>Assigned Central is not available</b>	The Information Center is switched off or not accessible
<b>No Central - check software revision</b>	Ask Biomed department to check software revisions
<b>Central cannot identify this bed</b>	Contact your Philips support engineer.

**During Operation**

During operation, problems are indicated by INOP messages and changes in the appearance of the network symbol.

<u>INOP / displayed symbol</u>	<u>What to do</u>
<p><b>No Central Monitoring</b></p> 	<p>For wired networks: check that the network cable is connected.</p> <p>For wireless networks:                      Check that the monitor is in range of an access point.<sup>a</sup>                      Check that no microwave ovens or other non-monitoring wireless devices are interfering with the connection.</p>
<p><b>Unsupported Lan</b></p>  <p>(blinking, inverse video)</p>	<p>Wireless and wired networks: there is a problem with the system configuration. An IP address may be missing or incorrectly assigned.</p>
<p><b>Blinking Wireless Symbol</b></p>  <p>(blinking)</p>	<p>You are moving out of signal range, move back into range, if possible. Once you have moved completely out of range, a “No Central Monitoring” INOP will appear.</p>

a. When you have been out of signal range for more than 1 minute the monitor will reset internal communication.

## Viewing Information for Other Patients from the Bedside

If your monitor is connected to the Information Center, and the appropriate functionality is available, you can access status or even patient information from other monitors in your unit, or even from other units.

### Getting an Overview of the Monitors in Your Care Group



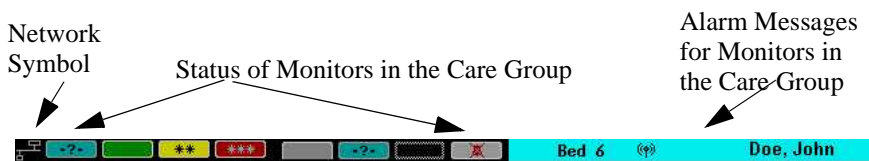

If the monitor is connected to the network and assigned to a Care Group (see “Assigning the Monitor to a Care Group” on page 113), the status of all the other monitors in the Care Group is displayed at the top of the screen.



### Status of Monitors in the Care Group

On the left of the status line are symbols for each of the first twelve beds in the Care Group.

		No data is available from the Information Center for this monitor.
		The monitor on which the status is being viewed. (blue outline)
		There is no alarm condition for this monitor.
		The highest priority alarm for this monitor is an INOP.
		The highest priority alarm for this monitor is a yellow alarm.
		The highest priority alarm for this monitor is a red alarm.

		Alarms are suspended for this monitor.
		This monitor is switched to standby.
		This monitor is in Demo mode.
		This monitor has lost connection to the Information Center.

If the patient window is being displayed for a bed in the Care Group, the symbol for that monitor is displayed with a white border. For more information, see “Viewing Patient Information from Another Monitor” on page 117

A blinking symbol means the alarm has not been acknowledged. If two colors are blinking, they show the highest priority alarm for the bed (acknowledged) and any unacknowledged alarms of a lower priority.

**Alarm and INOP Messages for Monitors in the Care Group**

Alarm and INOP messages for other monitors in the Care Group are displayed to the right of the care group status symbols. This message displays

- the severity of the alarm (\*\* for yellow alarms, \*\*\* for red alarms, in the appropriate color for the alarm),
- the bed label,
- a symbol indicating a wireless monitor or a telemetry monitor, and
- the name of the patient.

If there is more than one patient alarm for the Care Group, the alarm messages are rotated.

When an alarm occurs, the prompt message “Care Group alarm” is shown.

Depending on how your monitor has been configured, the patient information, or the list of patients in your Care Group can be displayed automatically when an alarm occurs. (Contact your biomedical department if you would like to have this configuration changed, or if neither of these windows appears).

## Viewing Patient Information from Another Monitor

If your monitor is connected to the Information Center, you can view the numerics, waves, alarms and INOPs for a patient connected to another monitor.

### Viewing Patient Information from a Monitor in your Care Group

To view the patient information for any patient connected to a monitor in your Care Group:

Press the **OtherPatient** SmartKey (you may have to press ◀◀ or ▶▶ to find this SmartKey, if it is configured).



OR

**Step 1.** Highlight the Care Group status information at the very top left of the screen.

**Step 2.** Press on the TouchStrip.

OR

**Step 1.** Press the **Setup** key.

**Step 2.** Scroll down through the list until **MyCareGroup** is highlighted.

**Step 3.** Press on the TouchStrip.

You will now see a list of the monitors in your Care Group, with

- the severity of the highest priority alarm for each monitor (-?- for INOPs, \*\* for yellow alarms, \*\*\* for red alarms),  
OR the crossed bell if alarms are disabled for the monitor.  
OR the standby symbol if the monitor is switched to standby.
- the bed label,
- a symbol indicating a wireless monitor or a telemetry monitor, and
- the name of the patient.

### *The Patient Window*

To see the numerics and a wave for a patient

**Step 1.** Highlight the patient in the list.

**Step 2.** Press on the touchstrip.

The patient window displays

## Viewing Information for Other Patients from the Bedside

- INOPS and alarms for the selected monitor rotating in the top row.
- The ECG wave. Other waves are available by pressing the **Next Wave** softkey.
- Large HR and SpO<sub>2</sub> numerics, and small PVC and other numerics. You can change the numerics shown by pressing the **More Vitals** softkey.

To see the numerics and waves for the patient in the next bed, use the **Next Bed** softkey.

To return to the list of beds in your Care Group, press the **My Care Group** softkey.

### **Viewing Patient Information for a Monitor in your Care Group with an Alarm Condition**

**Step 1.** Highlight the Care Group alarm message at the very top right of the screen.

**Step 2.** Press on the TouchStrip.

OR

Select the monitor as described in “Viewing Patient Information from a Monitor in your Care Group” on page 117.

The patient window is displayed.

### **Viewing Patient Information for Other Monitors in Your Unit**

**Step 1.** Access the list of monitors in your Care Group, as described in “Viewing Patient Information from a Monitor in your Care Group” on page 117.

**Step 2.** Press the **My Unit** softkey.

A list of the Information Centers in your unit is displayed.

**Step 3.** Highlight the Information Center to which the monitor is connected and press on the TouchStrip.

A list of all the monitors connected to this Information Center is displayed with

- the bed label for each monitor,
- a symbol indicating a wireless monitor or a telemetry monitor, and
- the name of the patient.

**Step 4.** Highlight the monitor in the list and press on the TouchStrip.

The patient window is displayed.



**Viewing  
Patient  
Information for  
Monitors in  
Other Units**

- Step 1.** Access the list of monitors in your Care Group, as described in “Viewing Patient Information from a Monitor in your Care Group” on page 117.
- Step 2.** Press the **Other Units** softkey.  
A list of all the available units is displayed.
- Step 3.** Highlight the name of unit in which the monitor is to be found and press on the TouchStrip.  
A list of the Information Centers in the unit is displayed.
- Step 4.** Highlight the Information Center to which the monitor is connected and press on the TouchStrip.  
A list of all the monitors connected to this Information Center is displayed with
- the bed label for each monitor,
  - a symbol indicating a wireless monitor or a telemetry monitor, and
  - the name of the patient.
- Step 5.** Highlight the monitor in the list and press on the TouchStrip.  
The patient window is displayed.

Viewing Information for Other Patients from the Bedside

# Measuring the ECG

This chapter covers measuring ECG and how to set up your ECG measurement.

At the end of the chapter you will find information on how to deal with common measurement problems (troubleshooting).

- Considerations when Measuring ECG . . . . . 122
- Preparing to Measure ECG . . . . . 122
- About ECG Leads . . . . . 124
- ECG Leads Monitored . . . . . 124
- Placing the Electrodes for Measuring ECG . . . . . 125
- Selecting the ECG Setup. . . . . 131
- Switching the ECG Measurement On and Off . . . . . 132
- Selecting the Volume of the Tone. . . . . 133
- Changing the Heart Rate Alarm Limits . . . . . 134
- Choosing EASI or Standard Lead Placement . . . . . 135
- Switching Pace Pulse Rejection On and Off. . . . . 135
- Setting up the ECG Wave . . . . . 139
- Troubleshooting the ECG Measurement. . . . . 144

---

## Considerations when Measuring ECG

---

### Warning

---

**DO NOT TOUCH THE PATIENT, OR TABLE OR INSTRUMENTS DURING DEFIBRILLATION**

---

---

---

### Caution

---

Use only ECG accessories listed in “ECG Accessories” on page 426.

---

---



The heart symbol signifies that the applied parts and their components are of Type CF and defib. proof according to IEC60601-1/EN60601-1.

- Interference from a instruments near the patient, and ESU interference can cause problems with the wave. Refer to “Preparing to Install Your Monitor” on page 318 for more details.

---

## Preparing to Measure ECG

**Step 1.** Select the correct type and size of patient cable. See “Preparing to Install Your Monitor” on page 318 for a list of the patient cables that are specified for use with the Measurement Server.

**Step 2.** Prepare the patients skin, prior to placing the electrodes. The skin is a poor conductor of electricity, so the preparation of the patient’s skin is important in getting good electrode to skin contact.

Recommendations:

- a. Shave hair from sites, if necessary.
- b. Wash sites thoroughly with soap and water. (never use ether or pure alcohol, because this increases skin resistance).

- c. Dry briskly to increase capillary blood flow in the tissues and remove skin cells and oil.

**Step 3.** Attach the clips or snaps to the electrodes before placing them.

**Step 4.** Place the electrodes on the patient. If you are not using pre-gelled electrodes, use electrode gel before placement.

Select a site where the signal will not be interfered with by either movement or bones. For information on placing electrodes for ECG measuring see “Placing the Electrodes for Measuring ECG” on page 125, and for respiratory measuring see “Placing the Electrodes for Measuring Respiration” on page 179.

---

**Warning**

---

**When you are connecting to the electrodes or the patient cable, make sure that the connectors never come into contact with other conductive parts, or with earth.**

**In particular, make sure that all of the ECG electrodes are attached to the patient, to prevent them from contacting conductive parts or earth.**

---

**Step 5.** If you are using two-part cables, attach the electrode cable to the patient cable.

**Step 6.** Plug the patient cable into the ECG connector.

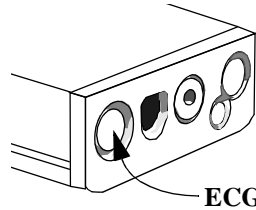

**Step 7.** Switch the monitor on, if it is not already on.

## About ECG Leads

To make it possible to compare measured ECG signals, the electrodes (or lead sets) are placed in standardized positions, forming so-called “leads.” To obtain ECG signals optimized for use in diagnosis and patient management in different care environments, different lead sets in varying lead placements can be used. You can use either standard lead placements or EASI lead placements with this monitor (see “Choosing EASI or Standard Lead Placement” on page 135).

When placing electrodes, choose a flat, non-muscular site where the signal will not be interfered with by either movement or bones. Correct lead placement is always important for accurate diagnosis. Especially in the precordial leads, which are close to the heart, QRS morphology can be greatly altered if an electrode is moved away from its correct location.

## ECG Leads Monitored

The monitor automatically recognizes the lead set connected.

<b>If you are using</b>	<b>these leads are available:</b>	<b>Resp is measured between electrodes:</b>
a 3-electrode set	I, II, III	RA and LL
a 5-electrode set	I, II, III, aVR, aVL, aVF, V and MCL	RA and LL
an EASI 5-electrode set	Derived leads: I, II, III, aVR, aVL, aVF, V1, V2, V3, V4, V5, V6	I and A

To change the ECG lead set, see “Selecting the ECG Lead” on page 139.

If a patient is transferred with a measurement server from an IntelliVue monitor with a 10-electrode lead set, the M3046A monitor recognizes this and ignores the chest electrodes V2 - V6.

## Placing the Electrodes for Measuring ECG

### 5-Electrode Set:

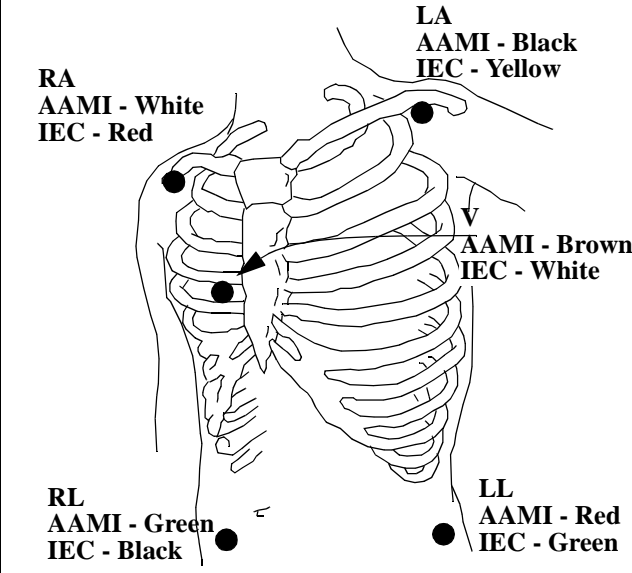
	Color (AAMI I)	(IEC)	
RA	White	Red	directly below the clavicle and near the right shoulder
LA	Black	Yellow	directly below the clavicle and near the left shoulder
RL	Green	Black	in the right lower abdomen
LL	Red	Green	in the left lower abdomen
V	Brown	White	on the chest as illustrated in the following pages for your required lead selections

For accurate V electrode placement and measurement, it is important to locate the 4th intercostal space.

## Placing the Electrodes for Measuring ECG

**Step 1.** Locate the 2nd intercostal space by first palpating the Angle of Lewis (the little bony protuberance where the body of the sternum joins the manubrium). This rise in the sternum is where the 2nd rib is attached, and the space just below this is the 2nd intercostal space.

**Step 2.** Palpate and count down the chest until you locate the 4th intercostal space.

V1	on the 4th intercostal space at the right sternal border
V2	on the 4th intercostal space at the left sternal border
V3	Midway between the V2 and V4 electrode positions
V4	on the 5th intercostal space at the left midclavular line
V5	on the left anterior axillary line, horizontal with the V4 electrode position.
V6	on the left midaxillary line, horizontal with the V4 electrode position.
V3R to V6R	on the right side of the chest in positions corresponding to those on the left.
VE	over the xiphoid process.
V7	on posterior chest at the left posterior axillary line in the 5th intercostal space.
V7R	on posterior chest at the right posterior axillary line in the 5th intercostal space.

A 5-electrode set gives you a choice of leads for each channel: I, II, III, aVR, aVL, aVF, V, MCL.



**3-Electrode Set (Standard)**

This electrode set is not suitable for the simultaneous measurement of more than one ECG lead. The monitor will turn off channels 2 and 3, and will select lead I, II, or III for channel 1, if one of these was not already selected.

	Color (AAMI I)	(IEC)	
RA	White	Red	place directly below the clavicle and near the right shoulder
LA	Black	Yellow	place directly below the clavicle and near the left shoulder
LL	Red	Green	Place in the left lower abdomen

### 3-Electrode Set (MCL<sub>1</sub>)

Select **Lead I** for measuring the MCL<sub>1</sub>.

As you will notice, you must attach electrode wires to areas of the chest that do not correspond with the electrode labels.

			Lead Selector in Lead I position)
	<b>Color (AAM I)</b>	<b>(IEC)</b>	
RA	White	Red	place directly below the clavicle and near the left shoulder
LA	Black	Yellow	place on the 4th intercostal space at the right sternal border (see the placement in "V1" on page 126)
LL	Red	Green	on the 5th intercostal space at the left midaxillary line

This modified electrode placement also allows you to measure the MCL<sub>6</sub> lead. Select **Lead II** on the monitor for MCL<sub>6</sub>.

This table shows the choice of leads for a 3-electrode set..

Lead Position	(-)	(+)	Reference
1 (I)	RA	LA	LL
2 (II)	RA	LL	LA
3 (III)	LA	LL	RA

## Placement for Paced Patients

The pacemaker lead should give the best wave for paced patients

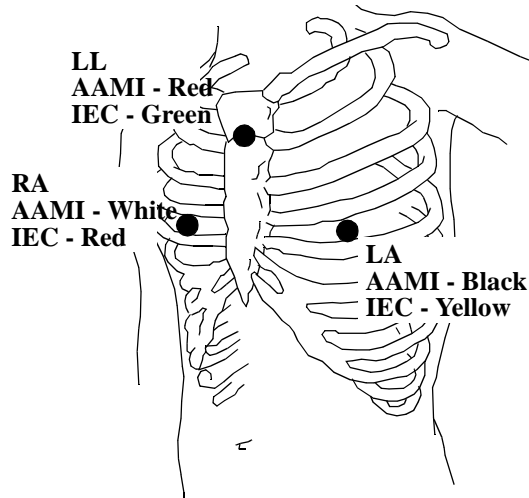

Typically the electrodes go below the nipple line, the RA and LA electrodes are placed at the 4th intercostal space.

## 10-Electrode Set

You can connect a 10-electrode lead set (for example, if a patient is transferred from an IntelliVue monitor), but only the standard five electrodes (RA, LA, RL, LL, and V) are used for monitoring. The rest are automatically ignored.

## EASI ECG Lead Placement

Using a standard 5-electrode set in EASI lead placement you can monitor three out of 12 standard ECG leads simultaneously and continuously at the bedside. EASI-derived 12-lead ECGs and their measurements are approximations to conventional 12-lead ECGs. As the 12-lead ECG derived with EASI is not exactly identical to the 12-lead conventional ECG obtained from a electrocardiograph, it should not be used for diagnostic interpretations.

Respiratory monitoring is also possible with the EASI placement; respiration is measured between the I and A electrodes.

Place the electrodes as accurately as possible to obtain the best quality EASI measurements.

## Placing the Electrodes for Measuring ECG

When EASI lead placement is selected, **EASI** is shown beside the 1mV calibration bar on the ECG wave on the display, and **EASI** is marked on any recorder strips and printouts.

**EASI Monitoring During INOP Conditions:** If one of the derived EASI leads has an INOP condition (for example, **LEADS OFF**), a flat line is displayed. After 10 seconds, the directly acquired EASI AI, AS, or ES lead (depending on which is available) is displayed with the corresponding lead label. This causes an arrhythmia relearn.

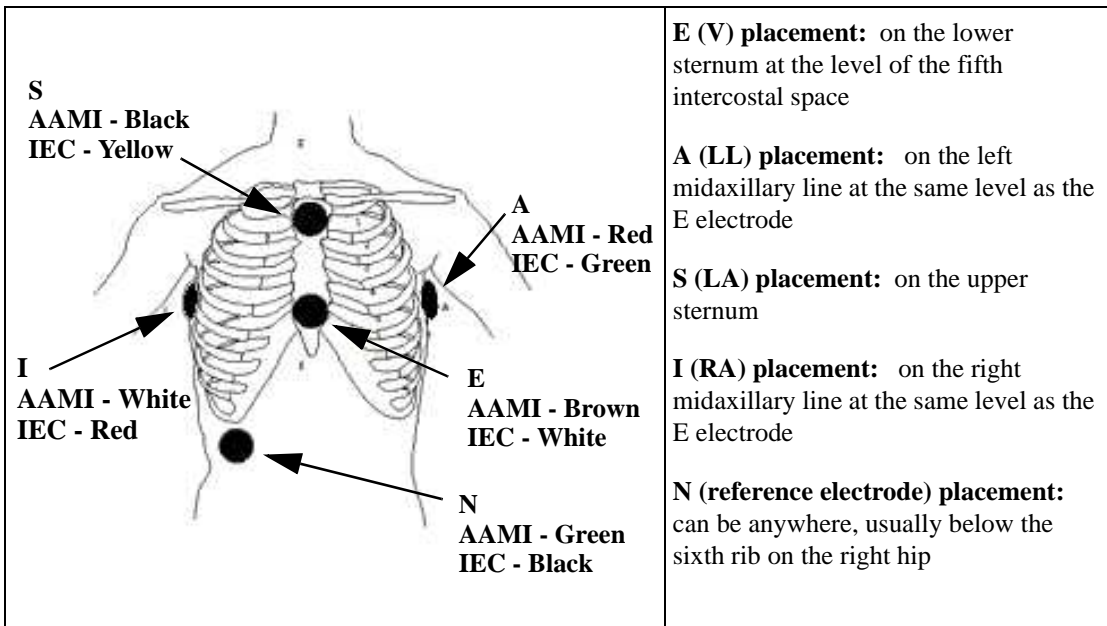

## Recommended Placement for Surgical Patients

---

### Warning

---

Use the orange 3 or 5 electrode ECG safety cable for measuring ECG in the operating room. These cables have extra circuitry to protect the patient from burns during cautery, and they decrease electrical interference. When using Electro-Surgical (ES) equipment, place the ECG electrodes half way between the ES grounding plate and the ES knife to prevent burning.

**These cables cannot be used for measuring respiration.**

---

The placing of the ECG electrodes will depend on the type of surgery that is being performed. For example, with open heart surgery, the electrodes can be placed laterally on the chest or on the back.

In the operating room, artifacts due to the use of Electro-Surgical (ES) equipment can sometimes affect the ECG wave. To help avoid this, place the electrodes on the right and left shoulders, and the right and left lower abdomen. Avoid placing the electrodes on the upper arms, as this can result in the ECG signal being too small.

---

### Caution

---

When using Electro-Surgical (ES) equipment, never place ECG electrodes near to the grounding plate of the ES device, as this can cause a lot of interference on the ECG signal.

---



---

## Selecting the ECG Setup

**Step 1.** Highlight the HR or Pulse numeric and press on the TouchStrip.  
OR

**Step 1.** Press the **Setup** key.

**Step 2.** Move the highlight to “**ECG**”.

**Step 3.** Press on the TouchStrip.

When you are finished with the ECG Setup, press the **Main Screen** key.

---

## Switching the ECG Measurement On and Off

In ECG setup (see “Selecting the ECG Setup” on page 131):

**Step 1.** Select **ECG On/Off**. This defines whether ECG is to be measured or not.

**Step 2.** Select the appropriate setting:

On	ECG will be measured.
Off	ECG will not be measured.

### Selecting the Source for the Heart Rate Numeric

In ECG setup (see “Selecting the ECG Setup” on page 131):

**Step 3.** Select **HR from**. This defines the source from which the Heart Rate numeric is calculated. Select the appropriate setting:

---

#### Warning

**All ECG alarms (includes arrhythmia alarms) will not occur if the HR source is other than ECG. This can also be the case if Auto Mode is selected as HR source.**

---

ECG	Use this if the Heart Rate is to be derived from the ECG signal. If this is selected and the ECG is switched off, the invasive pressure (if it is available) or the Pleth (if the pressure is not available) will be selected automatically as Pulse Rate source.
Pleth	Use this if the Pulse Rate is to be derived from the SpO <sub>2</sub> signal
PRESS Label	Use this if the Pulse Rate is to be derived from an appropriate, pulsatile invasive blood pressure signal.

AUTO	<p>If an ECG signal is available, the Heart Rate is derived from it. If there is no ECG signal (even if the ECG is switched on), and an invasive blood pressure transducer is connected, with an appropriate, pulsatile invasive blood pressure selected, this is selected for the Pulse Rate.</p> <p>If there is neither an ECG nor an appropriate pressure signal, the Pulse Rate is derived from the SpO<sub>2</sub> signal, if this is available.</p>
------	---

The alarm limits for the Heart Rate stay the same regardless of the source. The only exception is when a value below 30 bpm is selected for HR low limit and the source is switched to Pleth. In this case the limit will be changed to 30 which is the lowest value available for the pulse low limit. If the Heart Rate is derived from the Pleth or an invasive pressure, it will have the color for Pleth or the invasive pressure.

---

## Selecting the Volume of the Tone

**Step 1.** Highlight the **QRS Volume** SmartKey to see the current setting for the volume of the QRS tone (you may have to press **◀** or **▶** to find this SmartKey, if it is configured).



**Step 2.** Press the **QRS Volume** SmartKey repeatedly to select the volume of the QRS tone.

The volume can be set from 1 to 10 (or 0, which is off, if this has not been disabled). The current setting for the volume is displayed on the prompt line as you press the SmartKey.

OR

In ECG setup (see “Selecting the ECG Setup” on page 131):

**Step 1.** Select **QRS Volume**. This defines the volume of the tone that is to be heard each time a QRS complex is detected.

**Step 2.** Select the appropriate setting.

OR

**Step 1.** Press the **Setup** key.

**Step 2.** Move the highlight to “**QRS Volume**”.

**Step 3.** Press on the TouchStrip.

**Step 4.** Select the appropriate setting for the QRS volume.

**Step 5.** Exit the Setup menu.

---

## Changing the Heart Rate Alarm Limits

In ECG setup (see “Selecting the ECG Setup” on page 131):

**Step 1.** Select **High Limit** if you want to set the upper alarm limit for the heart/pulse rate.

Select **Low Limit** if you want to set the lower alarm limit for the heart/pulse rate.

**Step 2.** Select the appropriate setting.

The alarm limits range is from 15bpm to 300bpm.

---

Note

When arrhythmia analysis is switched off, only the HR-related alarms in the following list will be detected:

- Asystole
  - Ventricular fibrillation/Ventricular tachycardia
  - Extreme Tachycardia
  - Extreme Bradycardia
  - High heart rate
  - Low heart rate
-



## Enabling or Disabling ECG Heart Rate Alarm

In ECG setup (see “Selecting the ECG Setup” on page 131):

**Step 3.** Select **Alarms**. This defines whether the heart/pulse rate alarm is enabled.

**Step 4.** Select the appropriate setting

On	The alarms are enabled
Off	The alarms are disabled. The crossed bell symbol (X) will be displayed instead of the alarm limits.

---

## Choosing EASI or Standard Lead Placement

If EASI™ monitoring is available on your monitor, you must enable either standard lead placement or EASI lead placement.

- In the Setup ECG menu, select **LeadPlacmnt** and then **Standard** or **EASI**.

**EASI** is shown beside the 1mV calibration bar on the ECG wave on the display, and **EASI** is marked on any recorder strips and printouts.

For an electrode placement diagram, see “EASI ECG Lead Placement” on page 129.

---

## Switching Pace Pulse Rejection On and Off

### Paced Patients

When monitoring paced patients, it is important to set the pacing status correctly to enable pace pulse rejection. You can change pacing status in the ECG Setup or in the **Patient Identification** window (see “Admitting A New

Patient” on page 95). The pacing status is indicated by the appearance of the “Paced” or “Non-paced” symbol at the top of the main screen.

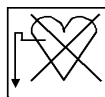

Non-Paced  
Symbol



Paced  
Symbol

## Warnings for Paced Patients

Some pace pulses can be difficult to reject. When this happens, the pulses are counted as a QRS complex, and could result in an incorrect HR and failure to detect cardiac arrest or some arrhythmias. Keep pacemaker patients under close observation.

- During complete heart block or pacemaker failure to pace/capture, tall P-waves (greater than 1/8 of the average R-wave height) may be erroneously counted by the monitor, resulting in missed detection of cardiac arrest.
- When arrhythmia monitoring paced patients who exhibit only intrinsic rhythm, the monitor may erroneously count pace pulses as QRS complexes when the algorithm first encounters them, resulting in missed detection of cardiac arrest.

For patients who exhibit intrinsic rhythm only, the risk of missing cardiac arrest may be reduced by monitoring these patients with the low heart rate limit at or slightly above the basic/demand pacemaker rate. A low heart rate alarm alerts you when the patient begins pacing. Proper detection and classification of the paced rhythm can then be determined.

- Pacemaker pulses may not be detected when the output of a defibrillator is plugged into the monitor. This may result in the arrhythmia algorithm's failure to detect pacemaker non-capture or asystole.

Instruments such as defibrillators produce a filtered ECG signal. When this signal is used as an input to the bedside monitor, it is filtered again. If this twice-filtered signal is passed to the arrhythmia algorithm, it may cause the algorithm to fail to detect pace pulses thus compromising paced patient monitoring performance.

- When an external pacemaker is being used on a patient, arrhythmia monitoring is severely compromised due to the high energy level in the pacer pulse. This may result in the arrhythmia algorithm's failure to detect pacemaker noncapture or asystole.

**Repolarization  
Tails**

Some unipolar pacemakers display pace pulses with repolarization tails. These tails may be counted as QRSs in the event of cardiac arrest or other arrhythmias.

If you note a visible repolarization tail, choose a lead that decreases the size of the repolarization tail.

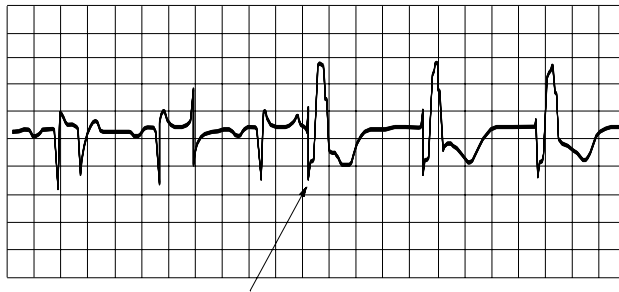

AVOID PACE PULSE REPOLARIZATION TAILS (NOTE WIDTH)

## Switching Pace Pulse Rejection On and Off

In ECG setup (see “Selecting the ECG Setup” on page 131):

**Step 1.** Select **Paced**. This sets whether the pace pulse rejection is on or off.

### Warning

**The pace pulse rejection must be switched on for paced patients. Switching pace pulse rejection off for paced patients may result in pace pulses being counted as regular QRS complexes which could prevent an asystole alarm from being detected.**

**Step 2.** Select the appropriate setting:

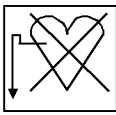
Yes	Use this for paced patients. The Pace Pulse Rejection is on, the pace pulses are shown on the ECG wave as a small dash. The “paced” symbol (see right column) is displayed in the top row next to the patient category.	
No	Use this for non-paced patients. The Pace Pulse Rejection is off, and pace pulses are not suppressed. The “non-paced” symbol (see right column) is displayed in the top row next to the patient category.	

- Pacemakers that create fused beats (pace pulse on top of the QRS complex) cannot be detected by the monitor’s QRS detector.

## Setting the Number of ECG Channels

In ECG setup (see “Selecting the ECG Setup” on page 131):

**Step 1.** Select **Active Ch.**

**Step 2.** Select how many ECG channels you want to be active:

ECG 1	One ECG channel is active.
ECG 1 + 2	Two ECG channels are active.
ECG 1 + 2 + 3	Three ECG channels are active.

---

## Setting up the ECG Wave

See “Selecting a Wave for the Screen” on page 44 for information on how to get the ECG wave onto the screen.

### Selecting the ECG Wave Channel Setup

- Step 1.** Highlight the ECG wave by lightly touching the TouchStrip beside it.
- Step 2.** Select the wave by pressing the TouchStrip.
- Step 3.** Press on the TouchStrip again to get the wave setup.

OR

- Step 1.** Enter the ECG setup (see “Selecting the ECG Setup” on page 131):
- Step 2.** Make sure that the correct Channel is selected.  
Change the channel by selecting **Channel**, then selecting **1**, **2**, or **3**.

### Selecting the ECG Lead

In the ECG wave channel setup (see “Selecting the ECG Wave Channel Setup” on page 139):

- Select **Lead**. This chooses the lead used for measuring ECG in the selected channel.

## Setting up the ECG Wave

- For a 5-electrode set, select the appropriate setting from among I, II, III, aVR, aVL, aVF, V and MCL

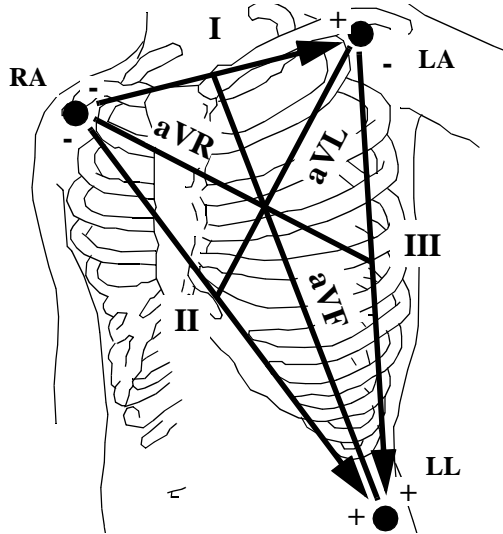

See “For accurate V electrode placement...” on page 125 for information on the V lead, and “3-Electrode Set (MCL1)” on page 128 for information on the MCL lead.

- For a 3-electrode set, select the appropriate setting from among I, II, III.
- For an EASI 5-electrode set, select the appropriate setting from among I, II, III, aVR, aVL, aVF, V1, V2, V3, V4, V5, V6. See the diagram on page 130.

If you are not getting a good ECG wave, and the electrodes are securely placed, try changing the lead.

### Example of Good Non-Paced ECG

The graphic below shows an ECG optimized for monitoring of a non-paced patient.

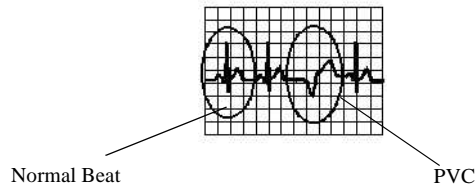

Normal QRS:

- Tall, narrow, with R-wave above or below the baseline (but not biphasic)
- T-wave smaller than R-wave; P-wave smaller than T-wave

### Example of Good Paced ECG

The graphic below shows an ECG optimized for monitoring of a paced patient.

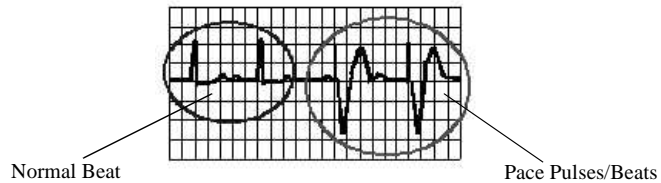

Normal QRS:

- Tall, narrow, and above or below the baseline (not biphasic)
- T-wave smaller than R-wave; P-wave smaller than T-wave.

### Synchronization Marks for a Defibrillator

If an Philips defibrillator is connected, the synchronization marks (vertical lines just after the QRS-complex) are also shown on the ECG wave.

On a printout, the marker is indicated by a spike on the wave rising to the upper limit of the channel.

---



---

#### **Warning**

---



---

**DO NOT TOUCH THE PATIENT, OR TABLE OR INSTRUMENTS DURING DEFIBRILLATION**

---



---

## Setting up the ECG Wave

### **Pace Pulse Marks**

When pace pulse detection is on, the pace pulse is shown on the ECG wave as a small dash (except in the third channel).

### **Changing the Size of the ECG Wave**

If the ECG wave is too Small or Clipped:

In ECG wave channel setup (see “Selecting the ECG Wave Channel Setup” on page 139):

**Step 1.** Make sure that the correct Channel is set.

Change the channel by selecting **Channel**, then selecting **1**, **2**, or **3**.

**Step 2.** Select **Size Up** to increase the size of the wave in the selected channel.

Select **Size Down** to decrease the size of the wave in the selected channel.

### **Changing the Size of All ECG Waves**

In ECG setup (see “Selecting the ECG Setup” on page 131):

**Step 1.** Select **Adjust Size**.

**Step 2.** Select the required adjustment factor from the line of pop-up keys:

- **x0.5** to halve the wave size
- **x1** to display the wave without zoom
- **x2** to double the size of the zoom
- **x4** to multiply the wave size by four

OR

To optimize the size of the ECG waves in all channels, select **AutoSize**.

### **Getting a Cleaner or More Detailed ECG Wave**

In ECG wave channel setup (see “Selecting the ECG Wave Channel Setup” on page 139):

- Select **Filter**. This defines the amount of smoothing that is done to the ECG waves in all the ECG channels.



Select the appropriate setting:

Filter	Use this if the signal is distorted, it reduces interference to the signal. In the operating room this reduces the artifact and interference from electrosurgical units. If the autofilter is configured to on and <b>monitor</b> or <b>diagnostic</b> <sup>a</sup> is selected, it will automatically switch to <b>filter</b> if electrosurgical interference is detected. Under normal measurement conditions, selecting <b>filter</b> may suppress the QRS complexes too much.
Monitor	Use under normal measurement conditions.
Diag	Use when diagnostic <sup>a</sup> quality is required. The monitor displays the unfiltered ECG wave. This enables you to detect changes such as R-wave notching, or discrete elevation or depression of the ST segments.

- a. The setting “diagnostic” selects the highest available ECG bandwidth which is 0.05 Hz to 150 Hz. The term “diagnostic” relates only to the ECG bandwidth requirements for diagnostic electrocardiographic devices as outlined in the ANSI/AAMI standard EC11-1991.

A letter indicating the filter is shown on the Main Screen underneath the wave label: **F** is filter, **M** is monitor, and **D** is diagnostic.

## Changing the Speed of the ECG Wave

In ECG wave channel setup (see “Selecting the ECG Wave Channel Setup” on page 139):

- Step 1.** Select **speed**. This defines the speed at which all the waves except the respiration wave are drawn across the screen, in millimeters per second (mm/s).
- Step 2.** Select the speed.

**Selecting ECG Cascading through Empty Waves**

In ECG wave channel setup (see “Selecting the ECG Wave Channel Setup” on page 139):

- Step 1.** Select **Cascading**. This defines whether the ECG wave scrolls into empty channels.
- Step 2.** Select the appropriate setting:

Yes	The ECG wave is extended into empty channels.
No	The ECG wave is displayed in one channel only.

**Selecting the Asystole Threshold**

In ECG setup (see “Selecting the ECG Setup” on page 131):

- Step 1.** Select **AsystoleThr** to enter a list of choices for the time an asystole is announced.
- Step 2.** Select the time from the choices:
  - **4.0, 3.5, 3.0, and 2.5 sec**

**Troubleshooting the ECG Measurement**

**If the HR Numeric is Displayed**

Check at the top left of the screen for a technical alarm message (an INOP).

**LEADS OFF XX**                      Check that the electrode indicated by *XX* (*RA, LA, LL, RL* or *V* for standard leads, or *E, A, S* or *I* for EASI leads) is attached.

**LEADS OFF RL**                      Make sure that the monitor is configured to one channel only if you are using a 3-electrode set

**If the HR Numeric Shows -?-**

- If the heartrate is being derived from the invasive pressure measurement, see “If the Pressure and Pulse Numerics Show -?-” on page 218.
- If the heartrate is being derived from the Pleth measurement, see “If the SpO<sub>2</sub> and Pulse Numerics Show -?-” on page 234.

If the heartrate is being derived from the ECG:

Check at the top left of the screen for a technical alarm message (an INOP):

- |                           |   |
|---------------------------|---|
| <b>ECG EQUIP MALF</b>     | Contact your biomedical department.<br>The ECG hardware is faulty.  |
| <b>LEADS OFF</b>          | Check that all of the required leads are attached,<br>and that none of the electrodes have been<br>displaced.                                 |
| <b>ALL ECG ALARMS OFF</b> | This message appears (if configured to do so)<br>when either the ECG alarms are switched off in<br>the ECG setup or the HR source is not ECG. |

## Troubleshooting the ECG Measurement

# Monitoring Arrhythmia

This chapter describes the ST/AR arrhythmia algorithm and how to set up the arrhythmia analysis. It includes the following sections:

- Introduction. . . . .148
- Levels of Arrhythmia Analysis. . . . .149
- Alarm Priorities and Timeout Periods . . . . .154
- Alarm Chaining. . . . .155
- Selecting the Arrhythmia Setup . . . . .159
- Switching Arrhythmia Analysis On and Off . . . . .159
- Changing the Arrhythmia Alarm Limits. . . . .162
- Status Messages . . . . .165
- Troubleshooting the Arrhythmia Analysis . . . . .168

## Introduction

The intended use of the ST/AR arrhythmia algorithm is to monitor a neonatal, pediatric, and adult patient's ECGs for heart rate and ventricular arrhythmias and produce alarms for one ECG lead. The ST/AR arrhythmia algorithm is capable of monitoring both paced and non-paced patients.

You can use arrhythmia analysis to aid in assessment of a patient's condition (for example, heart rate, PVC rate, rhythm, ectopics) and manage treatment accordingly. The monitor uses the user-selected primary and/or secondary ECG leads for single-lead or multi-lead arrhythmia analysis. In addition to detecting changes in the ECG, it also offers patient surveillance and alarm generation.

It is recommended that the alarm latching is set to Red alarms for **VisLatching** and **AudLatching** or at least Red alarms for **VisLatching** when using arrhythmia analysis. (See "Changing How Alarms Behave Until Silenced" on page 370 for further information.) Because of the transient nature of arrhythmia alarms, many arrhythmia conditions may go unnoticed if alarm latching is **Off**.

It is also recommended that event review is switched on, to enable the review of arrhythmia conditions (see "Changing How Alarms Behave Until Silenced" on page 370).

---

## Levels of Arrhythmia Analysis

The number of rhythms being classified and alarms being called depends on whether your monitor has basic or enhanced arrhythmia capability. The sections that follow describe each of these options.

---

### Note

When a monitor is connected to an Information Center, the level of arrhythmia analysis may differ between the monitor and the Information Center. The level of arrhythmia analysis on the monitor (basic or enhanced) will determine which level of arrhythmia analysis is performed for that patient.

---

### Basic Arrhythmia

The basic arrhythmia capability provides the basic cardiotech functions of heart rate and PVC rate, beat annotation, and the detection of the 10 alarms listed below.

- Asystole
- Ventricular Fibrillation
- Ventricular Tachycardia
- Extreme Tachycardia
- Extreme Bradycardia
- Pacer Not Capture
- Pacer Not Paced
- Frequent PVCs (PVC > limit)
- High heart rate
- Low heart rate

## **Enhanced Arrhythmia**

The enhanced arrhythmia capability configuration provides all of the basic functions, as well as the detection of the 12 additional alarms listed below.

### **Basic Alarms**

- Asystole
- Ventricular Fibrillation
- Ventricular Tachycardia
- Extreme Tachycardia
- Extreme Bradycardia
- Pacer Not Capture
- Pacer Not Paced
- Frequent PVCs (PVC > limit)
- High Heart Rate
- Low Heart Rate

### **Additional Alarms**

- Nonsustained V-Tach
- Supraventricular Tach
- Ventricular Rhythm
- Run PVCs
- Pair PVCs
- Pause
- Missed Beat
- R-on-T PVCs
- Ventricular bigeminy
- Ventricular trigeminy
- Multiform PVCs
- Irregular HR



## Ensuring Accurate Arrhythmia Monitoring

For accurate arrhythmia monitoring make sure the ECG wave is optimized for arrhythmia monitoring by performing the following steps:

Step	Action
1	Check the arrhythmia alarm limits in the Arrhythmia Setup (see “Selecting the Arrhythmia Setup” on page 159).
2	In the ECG Setup make sure the <b>Paced</b> setting is correct (see “Switching Pace Pulse Rejection On and Off” on page 135).
3	<p>Check the arrhythmia beat labels by pressing the <b>Arrhy Annot</b> SmartKey or selecting <b>Annotate Wave</b> in the Arrhythmia Setup. The beat labels indicate how the arrhythmia system is classifying beats.</p> <p>N = Normal  V = Ventricular Ectopic  S = Supra-ventricular Premature  P = Paced  ' = Pacer spike  L = Learning patient's ECG  A = Artifact (noisy episode)  ? = Insufficient information to classify beats  I = Inoperative condition (e.g., LEADS OFF)  M = Pause or missed beat</p> <p>When you press <b>Arrhy Annot</b> or select <b>DelayedWave</b> you get a wave that is delayed by 6 seconds along with the beat labels.</p>

Step	Action
4	<p>If you don't agree with how beats are labelled, you can cause arrhythmia to relearn the ECG by:</p> <ul style="list-style-type: none"> <li>• pressing the <b>Relearn</b> SmartKey, or</li> <li>• selecting <b>Relearn Arrhythmia</b> in the <b>Setup Arrhythmia</b> window, or</li> <li>• selecting <b>Relearn Arrhythmia</b> at the Information Center</li> </ul> <p>During the learning process beats are labeled with the letter <b>L</b> for the first valid 15 beats. The beat shape is then learned and a new template is created.</p> <p><i>Note</i>—Initiate learning only during periods of predominantly normal rhythm and when the ECG signal is relatively noise-free.</p> <hr/> <p style="text-align: center;"><b>Warning</b></p> <hr/> <p><b>If you initiate learning during ventricular rhythm the ectopics may be incorrectly learned as the normal QRS complex. This may result in missed detection of subsequent events of V-Tach and V-Fib.</b></p> <hr/>
5	<p>After relearning is complete, check the delayed arrhythmia wave to ensure that the algorithm is labeling the beats correctly.</p>
6	<p>If beats are still not classified correctly, check that the ECG is optimized for arrhythmia monitoring by changing the lead(s) or moving the electrodes, if needed. See page 153 for examples of good ECGs.</p>

**Example of Good Non-Paced ECG**

The graphic below shows an ECG optimized for arrhythmia monitoring of a non-paced patient.

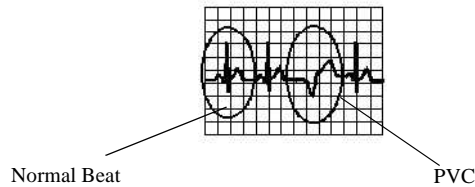
**Normal QRS:**

- Tall, narrow, with R-wave above or below the baseline (if possible, not biphasic)
- T-wave smaller than R-wave; P-wave smaller than T-wave

**Ectopic beats:**

- PVCs wider and different shape from normal beats
- PVCs not too tall or too small compared to the normal beat

**Example of Good Paced ECG**

The graphic below shows an ECG optimized for arrhythmia monitoring of a paced patient.

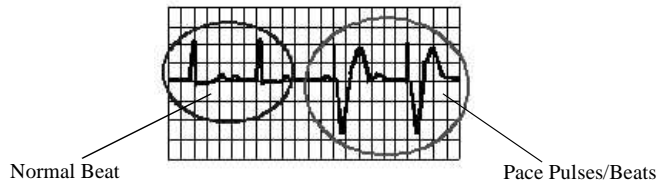
**Normal QRS:**

- Tall, narrow, and above or below the baseline (but not biphasic)
- T-wave smaller than R-wave; P-wave smaller than T-wave

**Ventricular paced beats:**

- Paced beat 1-2 mV in size
- Paced beat wider than Normal QRS
- Pace pulse large enough to be detected

## Alarm Priorities and Timeout Periods

Normally, an arrhythmia alarm is generated upon the detection of an alarm condition. However, there are certain situations that can inhibit the audible and visible indications of the alarm even though the alarm condition was detected. These situations include:

- A more serious alarm condition is active.
- A timeout period is in effect for a higher alarm in that chain (see “Alarm Chaining” on page 155).
- A timeout period is in effect for that alarm.

Timeout periods and alarm priority chains are explained below.

### Timeout Periods

When a yellow arrhythmia alarm is generated, it automatically initiates a timeout, or inhibitory period. This means that the timeout for the same alarm condition or another condition lower on the same alarm priority chain will not generate an alarm during the timeout period. If the timeout period is set to 0, the alarm is immediately reset when the alarm is no longer active. The length of the timeout period is configured for your unit.

When the timeout period has expired, the system is reset, and if the condition persists, the alarm will be generated again.

There are two levels of timeout periods:

- First level (configured to 0, 1, 2, 3, 4, or 5 minutes) applies to all yellow ECG alarms that are above Vent Bigeminy on the chain (Non Sustain VT, Vent Rhythm, Run PVCs, Pair PVCs, R-T PVCs, Pacer Not Capture, Pacer Not Paced, Pause SVT, Missed Beat, HR High, HR Low). See page 157 for an illustration of the alarm priority chain.
- Second level (configured to 0, 1, 2, 3, 4, 5, 10, or 15 minutes) applies to Vent Bigeminy and all alarms that are below Vent Bigeminy on the chain (Vent Bigeminy, Vent Trigeminy, PVCs >xx/min, Multiform PVCs, Irregular HR). See page 157 for an illustration of the alarm priority chain.

**Clearing the Timeout Period**

The timeout period is cleared if it is ended, main alarms are switched on or a learning phase occurs.

*Note*—A superseding alarm does not clear the timeout period.

---

**Alarm Chaining****Overview**

For arrhythmia alarms, the presence of multiple alarm conditions is quite possible. Announcing all of the detected alarm conditions would be confusing, and less serious conditions might hide a more serious condition. For this reason, the alarms are prioritized and put in alarm “chains” so that the most serious or highest priority alarm condition is announced. The diagram on page 157 shows the alarm priority chains.

**Alarm Groupings**

The alarm conditions detected by the ST/AR Arrhythmia algorithm are grouped into the following categories:

- PVC Alarms (for example, Pairs, Vent Rhythm)
- Beat Detection Alarms (for example, Pause, Pacer Not Capt)
- Rate Alarms (for example, Extreme Tachy, High/Low HR)

## **Alarm Announcing**

The monitor displays and announces the most recent equal or highest priority alarm unless the alarm is in a timeout period.

- Life threatening (red) alarms are announced first, since they have the highest priority.
- If there are no life threatening alarm conditions active, the highest priority alarm in any chain is announced.
- If alarm conditions in different chains are detected, the alarm condition that occurred most recently is announced. The exception is Irregular HR, which only occurs if no other alarms are occurring.

An activated alarm has no effect on subsequent alarm condition detection, but does prevent the activation of any alarm lower on the same chain. For example, if there is an active Vent Bigeminy alarm, a PVCs > xx/min will not become active because it is lower on the same chain. However, a high HR alarm will become active because it is on another chain.

Higher priority alarms will supersede the previous alarm, causing the indicators to occur again. For example, if a Vent Trigeminy alarm is active and a Pair PVCs occurs, the Pair alarm will be activated. Only one arrhythmia alarm can be active for a patient at any one time.

The alarms in each category are prioritized according to the level of seriousness.

---

---

### **Warning**

**All ECG alarms (includes arrhythmia alarms) will not occur if the HR source is other than ECG. This can also be the case if Auto Mode is selected as HR source.**

---

---

# Alarm Priority Chains

## Enhanced Arrhythmia

The diagram below shows the alarm priority chains for enhanced arrhythmia. The alarms in each category are prioritized according to the level of seriousness.

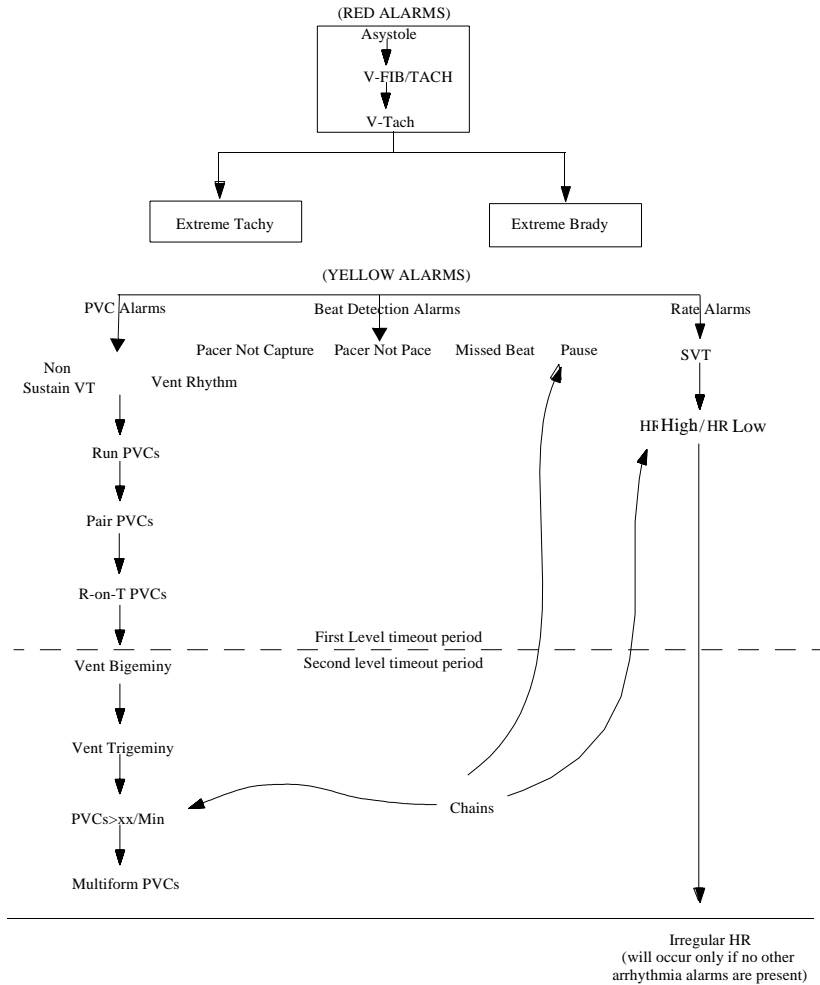

## Basic Arrhythmia

The diagram below shows the alarm priority chains for basic arrhythmia. The alarms in each category are prioritized according to the level of seriousness.

Alarm Chaining

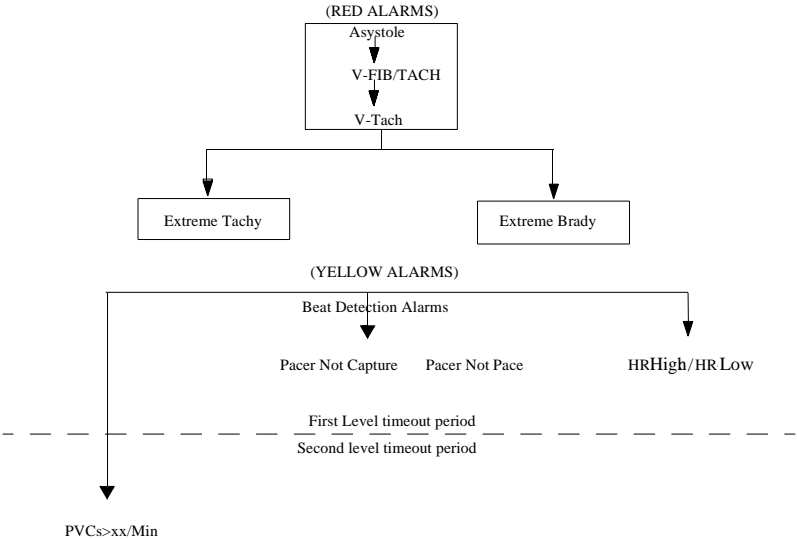



---

## Selecting the Arrhythmia Setup

**Step 1.** Highlight the PVC numeric and press on the TouchStrip.

OR

**Step 1.** Press the **Setup** key.

**Step 2.** Move the highlight to “**Arrhythmia**”.

**Step 3.** Press on the TouchStrip.

OR

**Step 1.** Go into ECG setup (see “Selecting the ECG Setup” on page 131).

**Step 2.** Move the highlight to “**Arrhythmia**”.

**Step 3.** Press on the TouchStrip.

When you are finished with the Arrhythmia Setup, press the **Main Screen** key.

---

## Switching Arrhythmia Analysis On and Off

In arrhythmia setup (see “Selecting the Arrhythmia Setup” on page 159):

**Step 1.** Select **Arrhythmia On/Off**. This defines whether Arrhythmia analysis is to be performed, or not.

**Step 2.** A message and a **Confirm** key appear at the bottom of the screen.

Press **Confirm** to change the status of Arrhythmia On/Off (for example, if On is shown on the screen, pressing Confirm will switch the arrhythmia analysis Off)

Note

1. When arrhythmia analysis is switched off, only the HR-related alarms in the following list will be detected:
    - Asystole
    - Ventricular fibrillation/Ventricular tachycardia
    - Extreme Tachycardia
    - Extreme Bradycardia
    - High heart rate
    - Low heart rate
  2. When arrhythmia analysis is switched off, HR High and HR Low alarms are normal yellow alarms and no timeout periods are active.
  3. When arrhythmia analysis is switched off, the ST measurement is automatically switched off too.
- 

---

## Selecting Single- or Multi-Lead Analysis

Your monitor supports both single- and multi-lead arrhythmia analysis. To choose between the two, do the following:

**Step 1.** Go into ECG setup (“Selecting the ECG Setup” on page 131).

**Step 2.** Move the highlight to **Analysis**.

**Step 3.** Press on the TouchStrip. The choices **SingleLd** and **MultiLd** pop up.

**Step 4.** Highlight your choice and press on the TouchStrip.

When you are finished with the ECG Setup, press the **Main Screen** key.

---

## Reviewing Beat Labels

In arrhythmia setup (see “Selecting the Arrhythmia Setup” on page 159):

**Step 1.** Press the SmartKey **Arrhy Annot** or select **Annotate Wave**.

You get a wave that is delayed by 6 seconds along with the beat labels. If you don't agree with how beats are labelled, you can cause arrhythmia to relearn the ECG by selecting **Relearn Arrhythmia** or pressing the **Relearn** SmartKey (see “Relearning Arrhythmia” below).

---

## Relearning Arrhythmia

In arrhythmia setup (see “Selecting the Arrhythmia Setup” on page 159):

**Step 1.** Press the SmartKey **Relearn** or select **Relearn Arrhythmia**.

**Step 2.** Wait until the beat labelling on the ECG wave changes from L (for Learning) to labeling appropriate to the wave (see Step 3 on page 151 for a list of labels).

---

### Warning

---

**If you initiate learning during ventricular rhythm, the ectopics may be incorrectly learned as the normal QRS complex. This may result in missed detection of subsequent events of V-Tach and V-Fib.**

---

---

**EASI Monitoring During INOP Conditions:** If one of the derived EASI leads has an INOP condition (for example, **LEADS OFF**), a flat line is displayed. After 10 seconds, the directly acquired EASI AI, AS, or ES lead (depending on which is available) is displayed with the corresponding lead label. This causes an arrhythmia relearn.

## Changing the Arrhythmia Alarm Limits

The following Alarms have limits which can be adjusted:

Alarm	Range
Asystole Alarm Threshold	2.5 to 4.0 sec
Pause Alarm Threshold	1.5 to 2.5 sec
<b>Vtach:</b> HR setting Run setting	<b>20 - 300 bpm</b> <b>3 - 99 PVCs</b>
PVCs/min	1 - 99 PVCs/min
Ventricular Rhythm <sup>a</sup>	3 - 99 PVCs
<b>SVT:</b> <sup>a</sup> HR setting Run setting	<b>120 - 300 bpm</b> <b>3 - 99 SVs</b>

a. only available with the enhanced arrhythmia capability

In arrhythmia setup (see “Selecting the Arrhythmia Setup” on page 159):

**Step 1.** Select the alarm to be adjusted.

**Step 2.** Select the appropriate setting

The following diagram illustrates the conditions under which the following PVC events are generated:

- Ventricular Tachycardia
- Non-Sustained Ventricular Tachycardia
- Ventricular Rhythm
- Run PVCs
- Pair PVCs

Each of the PVC events are detected on the basis of the current ventricular heart rate and/or the number of consecutive PVCs counted (referred to as runs).

Each event is represented by a zone bounded by 2 or more lines. Each line represents a user adjustable limit (in Setup) or range (Config Mode) except for the Pair PVC condition.

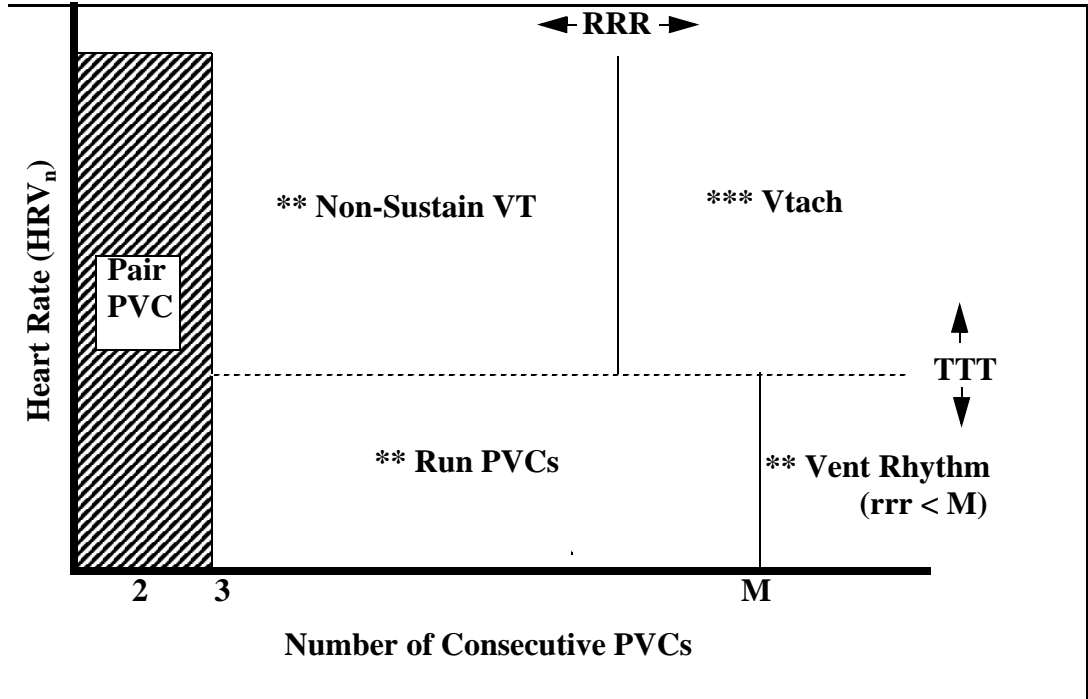

Adjustable Limits:

- TTT is the V-Tach Heart Rate limit
- RRR is the V-Tach Run limit
- M is the Ventricular run limit

## Switching Arrhythmia Alarms On and Off

### Switching Alarms On and Off Individually

The following alarms can be individually switched on and off:

- NON-Sustain VT<sup>1</sup>
- Vent Rhythm<sup>1</sup>
- Run PVCs<sup>1</sup>
- Pair PVCs<sup>1</sup>
- Bigeminy<sup>1</sup>
- Trigeminy<sup>1</sup>
- PVCs/min
- Multiform PVCs<sup>1</sup>
- Pacer not capture
- Pacer not pace
- Pause<sup>1</sup>
- Missed Beat
- SVT<sup>1</sup>
- R-on-T PVCs<sup>1</sup>
- Irregular HR<sup>1</sup>

In arrhythmia setup (see “Selecting the Arrhythmia Setup” on page 159):

**Step 1.** Select the alarm from the list.

**Step 2.** Select the appropriate setting, **On** or **Off**.

### Switching All Yellow Alarms On or Off

In addition, all arrhythmia yellow alarms listed in “Switching Alarms On and Off Individually” above can be switched on and off together:

In arrhythmia setup (see “Selecting the Arrhythmia Setup” on page 159), to switch all yellow alarms off:

**Step 1.** Select **All Yellow Off**,

and to switch all yellow alarms on:

**Step 1.** Select **All Yellow On**.

---

1. only available with the enhanced arrhythmia capability

## Status Messages

The monitor displays two types of status messages:

- Rhythm Messages -- to indicate the patient's rhythm.
- Ectopic Status Messages -- to indicate the presence of ectopic beats (if present).

These status messages are shown directly in the first ECG wave channel and are updated every second.

*Note*—If you have basic arrhythmia capability, you will get only messages for the basic alarms (see “Levels of Arrhythmia Analysis” on page 149).

### Rhythm Status Messages

The label E or B in the second column below indicates whether the message appears with enhanced (E) arrhythmia capability only or also with basic (B) arrhythmia capability.

Message	Basic /Enh.	Description
ASYSTOLE	B	No QRS for 4 consecutive seconds in absence of vent fib or chaotic signal
VENT FIB/TACH	B	A fibrillatory wave for 4 consecutive seconds
V-TACH	B	A dominant rhythm of adjacent Vs and a HR > the V-Tach Heart Rate Limit
SUST V-TACH	B	Ventricular Tachycardia rhythm for more than 15 seconds
VENT RHYTHM	B	A dominant rhythm of adjacent PVCs and a HR less than or equal to the V-Tach Heart Rate Limit
VENT BIGEMINY	E	A dominant rhythm of N, V, N, V (N=supraventricular beat, V=ventricular beat)
VENT TRIGEMINY	E	A dominant rhythm of N, N, V, N, N, V (N=supraventricular beat, V=ventricular beat)

## Status Messages

Message	Basic /Enh.	Description
PACED RHYTHM	B	A dominant rhythm of paced beats
IRREGULAR HR	E	Consistently irregular rhythm
SINUS BRADY* SINUS RHYTHM* SINUS TACHY*	B	A dominant rhythm of SV beats preceded by P-waves
SV BRADY* SV RHYTHM* SV TACHY*	B	A dominant rhythm of SV beats not preceded by P-waves
UNKNOWN RHYTHM	B	Rhythm cannot be determined
LEARNING ECG	B	Algorithm is learning the ECG beat morphology
LEARNING RHYTHM	B	Algorithm is learning the rhythm of the classified beats

\* The Sinus and SV rhythm messages are updated based on the current heart rate, taking into account the patient category, adult, pediatric, or neonatal. In order to make a transition from one rhythm status to another (for example, from Sinus Rhythm to Sinus Brady) the HR must be in the new range for 5 beats.

The table below indicates the ranges for Sinus and SV rhythms.

Rhythm	Adult Range	Ped Range	Neo Range
Brady	15 to 60	15 to 80	15 to 90
Normal	60 to 100	80 to 160	90 to 180
Tachy	> 100	> 160	> 180



## Ectopic Status Messages

The label E or B in the second column below indicates whether the message appears with enhanced (E) arrhythmia capability only or also with basic (B) arrhythmia capability.

Message	Basic /Enh	Explanation
(No message displayed)	B	No ectopic activity within the last minute
RUN PVCs [longest run in last minute]	E	More than 2 consecutive PVCs within the last minute
PAIR PVCs [number of pairs in last minute]	E	Pair PVCs within the last minute
PACER NOT CAPT [number of pacer not captured episodes in last minute]	B	Pause with pace pulse (paced patient only) within the last minute
PACER NOT PACE [number of pauses with no pacer in last minute]	B	Pause without pace pulse (paced patient only) within the last minute
PAUSE [number of pauses in last minute]	E	Pause with HR < 120 or Pause for 1 second for a HR > 120 within the last minute
R-ON-T PVCs	E	R-ON-T detected within the last minute
MULTIFORM PVCs [number of PVCs in last minute]	E	Multiform PVCs detected within the last minute
FREQUENT SVPBs [number of SVPBs in last minute]	B	SVPB count within last minute is greater than 5
SVPBs [number of SVPBs in last minute]	B	1-5 SVPBs in the last minute with a sinus rhythm and no Vs

Message	Basic /Enh	Explanation
SV BEATS [number of SVs in last minute]	B	SV count within last minute (if 0 this message is blank) and rhythm status is PACED
PACED BEATS [number of paced beats in last minute]	B	Paced beat count within last minute (if 0 this message is blank) and rhythm status is not PACED

## Troubleshooting the Arrhythmia Analysis

If a technical alarm message (an INOP) appears at the top right of the screen, check the list below for actions to take.

### Cannot analyze ECG

Improve lead position and/or reduce patient motion.

If you are not getting a reliable HR because the signal is below a minimum amplitude, unstable, or contains artifact, *and* you have tried to improve the system performance by choosing another lead and changing electrodes, you may consider turning arrhythmia analysis off.

### Some ECG Alarms Off

This message appears (if configured to do so) when the on/off settings of the yellow arrhythmia alarms differ from the current QuickSet.

# Monitoring ST Segment

This chapter describes the ST/AR ST algorithm and how to set up the ST measurement. It includes the following sections:

- Introduction . . . . .170
- Adjusting the measurement points . . . . .172
- Switching ST On and Off . . . . .174
- Changing the ST Alarm Limits. . . . .175
- Switching ST Alarms On and Off. . . . .175
- Troubleshooting the ST Measurement . . . . .175

## Introduction

The intended use of the ST Segment Monitoring is to monitor ST segment elevation or depression for each available ECG lead and produce alarms simultaneously. ST values update with every measurement period and enunciate alarms as they are detected. ST Segment monitoring is restricted to adult patients only and cannot be switched on when a patient category other than adult is selected.

With EASI monitoring, ST analysis is performed on up to 12 leads. Assessment of EASI-derived 12-lead ST measurements is recommended for adult patients that meet the following parameters:

- Ages: 33 to 82 years
- Heights: 147 to 185 cm (58 to 73 in)
- Weights: 53 to 118 kg (117 to 261 lbs)
- Height-to-Weight Ratios: 1.41 to 2.99 cm/kg (0.25 to 0.54 in/lb)

You can perform ST analysis on both non-paced and atrially paced patients.

## The Measurement

The ST measurement for each beat complex is the vertical *difference* between two measurement points. The **isoelectric point** provides the baseline for the measurement and the **ST point** provides the other measurement point. It is positioned with reference to the J-point.

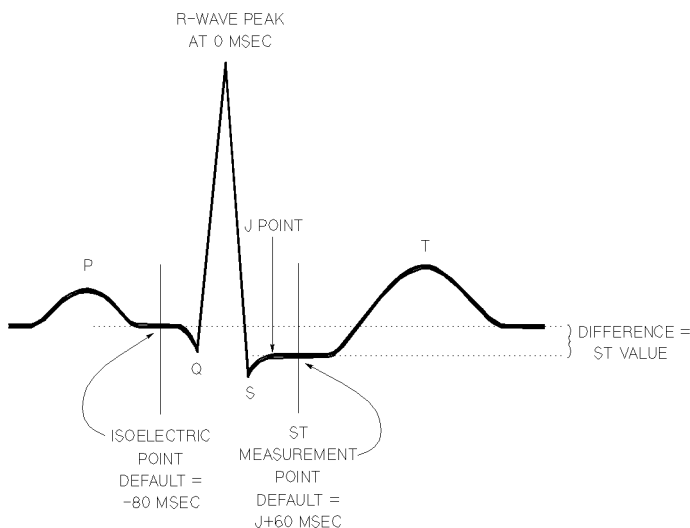

---

### Warning

---

**This device provides ST level change information; the clinical significance of the ST level change information should be determined by a physician.**

---

## How the Algorithm Works

ST analysis uses the ST/AR arrhythmia beat classification to select only normal and atrially paced beats for its analysis.

The ST/AR ST algorithm processing includes special ST filtering, beat selection and statistical analysis, calculation of ST segment elevations and depressions, and wave generation.

## Displayed ST Data

ST data displays as a value on the main screen and in the **ST Adjust Points** window. A positive value indicates ST segment elevation; a negative value indicates depression.

## Selecting the ST Setup

**Step 1.** Highlight one of the ST values under the first ECG channel and press on the TouchStrip.

OR

**Step 1.** Press the **Setup** key.

**Step 2.** Move the highlight to **ST Analysis**.

**Step 3.** Press on the TouchStrip.

OR,

**Step 1.** Get into the ECG Setup.

**Step 2.** Move the highlight to **ST Analysis**.

**Step 3.** Press on the TouchStrip.

When you are finished with the ST Setup, press the **Main Screen** key.

---

## Adjusting the measurement points

In the ST setup you can adjust the ST measurement points to ensure accurate data. There are three measurement cursors:

- The ISO measurement cursor positions the isoelectric point in relation to the R-wave peak.
- The J-point cursor positions the J-point in relation to the R-wave peak. The purpose of the J-point is to correctly position the ST measurement point.
- The ST measurement cursor positions the ST point a fixed distance from the J point.

*Note*—The ST measurement points may need to be adjusted if the patient's heart rate or ECG morphology changes significantly.

**Step 1.** Get into the ST Setup (see “Selecting the ST Setup” on page 172).

**Step 2.** Select **Adjust Points**.

**Step 3.** If you need to adjust the ISO (isoelectric) point:

- Using the arrow keys, position the bar in the middle of the flattest part of the baseline (between the P and Q waves or in front of the P wave)

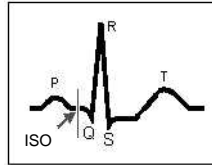

**Step 4.** To adjust the J point, if necessary:

- Use the **Select Point** softkey to select the bar marking the J point (when selected it appears white)
- Using the arrow keys, position the bar at the end of the QRS complex and the beginning of the ST segment.

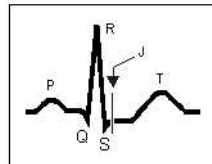

**Step 5.** To adjust the ST point, if necessary:

- Use the **Select Point** softkey to select the dotted bar marking the ST point (when selected it appears white)
- Select either the **J + 60** or **J + 80** softkey to position the bar at the midpoint of the ST segment.

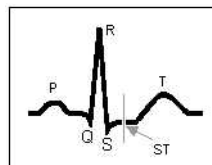

**Step 6.** After making all adjustments, use the **Apply Changes** softkey to activate the new settings.

## Switching ST On and Off

In the ST setup you can switch ST monitoring on and off for individual or all ECG leads. You would turn ST monitoring off if:

- You are unable to get any lead that is not noisy.
- Arrhythmias such as atrial fib/flutter cause irregular baseline.
- The patient is continuously ventricularly paced.
- The patient has left bundle branch block.

**Step 1.** Get into the ST Setup(see “Selecting the ST Setup” on page 172).

**Step 2.** If you want to switch all ST monitoring on or off, select **ST Analysis** and then select **On** or **Off**.

**Step 3.** Switch individual leads on or off by selecting the lead then selecting **On** or **Off**.

---

Note

ST monitoring is automatically switched off if:

- Arrhythmia analysis is switched off, or
  - The Patient Category is not Adult
-



---

## Changing the ST Alarm Limits

For each lead, high and low alarm limits can be set.

In ST setup (see “Selecting the ST Setup” on page 172):

**Step 1.** Select the alarm to be adjusted.

**Step 2.** Select the appropriate setting. Set the high and low alarm limits based on your assessment of the patient's clinical condition, unit protocols, or physician orders or medication specified limits. A good guideline is + 1.0 mm or - 1.0 mm from the patients's ST, or follow your unit protocol.

These limits can also be set automatically by the monitor around the patient's current ST value using the AutoLimits function (see “Setting Automatic Alarm Limits” on page 59).

---

## Switching ST Alarms On and Off

In ST setup (see “Selecting the ST Setup” on page 172):

**Step 1.** Select **Alarms**.

**Step 2.** Select the appropriate setting, **On** or **Off**.

---

## Troubleshooting the ST Measurement

If a technical alarm message (an INOP) appears at the top right of the screen, check below for actions to take.

**Cannot analyze ST**

Review the ECG signal quality and the placement of the Iso and J points.

## Troubleshooting the ST Measurement

# Measuring Respiration Rate (RESP)

This chapter covers measuring respiration and how to set up your respiration measurement.

At the end of the chapter you will find information on how to deal with common measurement problems (troubleshooting).

- Preparing to Measure Respiration. . . . .178
- Placing the Electrodes for Measuring Respiration . . . . .179
- Selecting the Respiration Setup . . . . .181
- Selecting the Respiration Source and Switching Respiration On/Off .181
- Changing how Respiration is Detected. . . . .182
- Setting Up the Respiration Wave . . . . .184
- Setting Up the Respiration Alarm. . . . .184
- Troubleshooting the Respiration Measurement . . . . .186

---

---

## **Warning**

---

---

**This device is not intended for use as an apnea monitor.**

---

---

---

Note                      The respiration measurement does not recognize obstructive and mixed apneas — it only indicates an alarm when a pre-adjusted time has elapsed since the last detected breath.

---

---

Note                      Implantable pacemakers which are minute ventilation rate-adaptive can occasionally interact with the impedance measurement of cardiac monitors causing the pacemakers to pace at their maximum programmed rate.

---

---

## Preparing to Measure Respiration

---

### Caution

---

Use only non-OR ECG accessories listed in “ECG Accessories” on page 426. You cannot measure respiration if you are using an OR ECG cable set.

---

If you are already measuring ECG, and are not using an orange (OR) cable set, you do not need to use additional electrodes, but extra care must be taken in the electrode placement.

**Step 1.** Plug the patient cable into the ECG/RESP connector. See “ECG

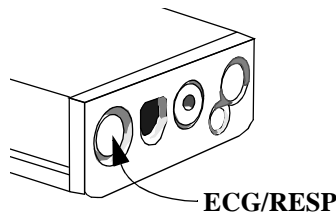

Accessories” on page 426 for information on RESP accessories.

**Step 2.** Prepare the patients skin, prior to placing the electrodes.

The skin is a poor conductor of electricity, so the preparation of the patient’s skin is important in getting good electrode to skin contact.

Recommendations:

- Shave hair from sites, if necessary.
- Wash sites thoroughly with soap and water. (never use ether or pure alcohol, because this increases skin resistance).
- Dry briskly to increase capillary blood flow in the tissues and remove skin cells and oil.
- Attach clip or snap to electrode before placing them.

**Step 3.** Place the electrodes on the patient. If you are not using pre-gelled electrodes, use electrode gel before placement.

Select a site where the signal will not be interfered with by either movement or bones. For information on placing electrodes for measuring ECG see “Placing

the Electrodes for Measuring ECG” on page 125, and for measuring respiratory see “Placing the Electrodes for Measuring Respiration” on page 179.

**Step 4.** Attach the electrodes to the patient cable.

**Step 5.** Switch the monitor on, if it is not already on.

---

## Placing the Electrodes for Measuring Respiration

If the patient is using the thoracic muscles, you can use the electrode placement shown here:

### 5-Electrode Set

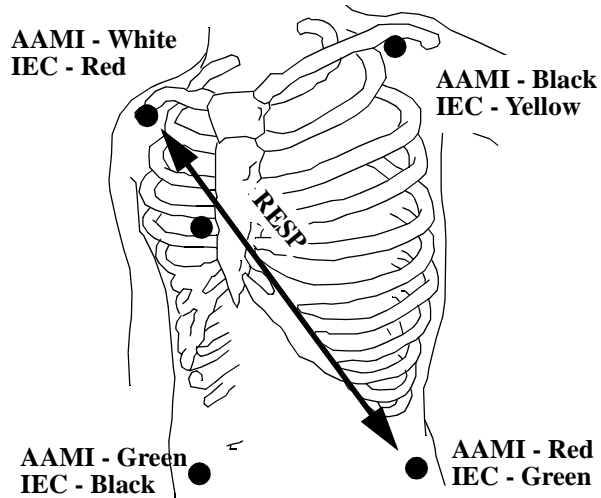

### 3-Electrode Set

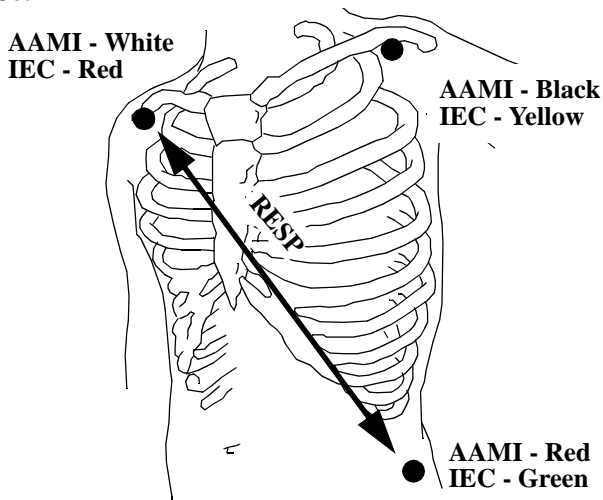

---

Note

Some patients, due to their clinical condition, expand their chest laterally. In these cases it is best to place the two respiratory electrodes laterally in the right midaxillary and left lateral chest areas at the maximum point of breathing movement to optimize the respiratory wave. In this case, you will not be able to measure ECG at the same time (the ECG measurement is taken from the same electrode set)

---

### EASI Lead Placement

When monitoring ECG with an EASI lead set, Respiration is measured between the electrodes I and A. See page 130 for a diagram showing EASI lead placement.

---

## Selecting the Respiration Setup

**Step 1.** Highlight the Resp numeric and press on the strip.  
OR

**Step 1.** Press the **Setup** key.

**Step 2.** Move the highlight to “Resp”.

**Step 3.** Press on the strip.

When you are finished with the Resp Setup, press the **Main Screen** key.

---

## Selecting the Respiration Source and Switching Respiration On/Off

If Respiration and CO<sub>2</sub> are measured, two respiration rates are available. One of the respiration rates must be selected for monitoring and alarming. To select the respiration rate source:

**Step 1.** Select respiration setup (see “Selecting the Respiration Setup” on page 181).

**Step 2.** Select **Resp Source**

**Step 3.** Select the appropriate setting:

AwRR	The respiration rate from the CO <sub>2</sub> measurement is used for monitoring and alarming. The Respiration measurement is turned off.
RR	The respiration rate from the Respiration measurement is used for monitoring and alarming. The AwRR channel from the CO <sub>2</sub> measurement is turned off.
Auto	The monitor automatically selects a source; AwRR if available, RR if AwRR not available.
Off	Both respiration sources are switched off.

---

## Changing how Respiration is Detected

In RESP Setup (see “Selecting the Respiration Setup” on page 181).

**Step 1.** Select **Auto/Man**. This defines how the respiration is counted.

**Step 2.** Select the appropriate setting:

Auto	<p>The monitor counts the respiration and adjusts the detection level automatically depending on the wave height, the presence of cardiac artifact and the absence of valid breaths.</p> <p>Select this for situations</p> <ul style="list-style-type: none"><li>• where breathing is spontaneous with or without continuous positive airway pressure (CPAP)</li><li>• with ventilated patients, except Intermittent Mandatory Ventilation (IMV)</li><li>• when the respiration rate is not close to the heart rate.</li></ul> <p><i>Note</i>—If the ECG is switched off, the respiration detection level is set higher to prevent the detection of cardiac overlay as respiration.</p>
Manual	<p>You set the detection level for counting the respiration. <b>It is important to remember that if the depth of breathing changes, you may need to change the detection level.</b></p> <p>Select this for situations:</p> <ul style="list-style-type: none"><li>• when the respiration rate and the heart rate are close.</li><li>• when respiration is weak: heart activity or movements in the chest wall due to the heart can cause artifacts (try repositioning the electrodes to improve the signal).</li></ul> <p>The manual mode is more sensitive than the auto mode to changes and artifacts. Check the wave on the screen to make sure that it represents the patients breathing pattern.</p> <p>See also “Adjusting the Manual Respiration Detection Level” on page 183.</p>



## Adjusting the Manual Respiration Detection Level

If you have selected Manual detection:

**Step 1.** Select Respiration setup (see “Selecting the Respiration Setup” on page 181).

**Step 2.** Select **Manual Up** or **Manual Down**. This changes the trigger level. The respiration detection level is shown as a horizontal line across the respiratory wave. Each downward stroke which crosses the line is counted as a respiration.

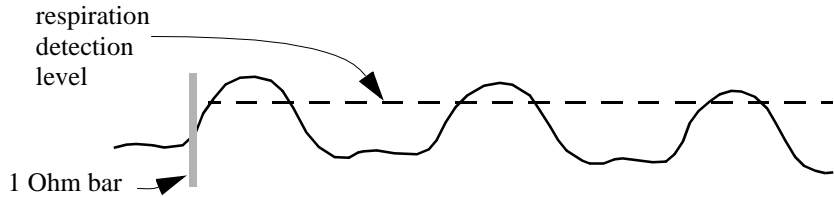

---

### Warning

---

**If you do not set the detection level for the respiration correctly in manual operation, it may not be possible to detect apnea.**

**If you set the detection level too low, the monitor is more likely to detect cardiac activity, and to falsely interpret cardiac activity as respiratory activity in the case of apnea.**

**If the detected respiration rate is close to the heart rate, this is indicated by the text HR=RR in the respiration channel.**

---

## Setting Up the Respiration Wave

See “Selecting a Wave for the Screen” on page 44 for information on how to get the respiration wave onto the screen.

---

### **Warning**

---

#### **Changing the Size of the Respiration Wave**

**Check the respiration detection level after you have increased or decreased the size of the respiration wave.**

---

---

In RESP setup (see “Selecting the Respiration Setup” on page 181):

- Step 1.** Select **Size Up** to increase the size of the wave.  
Select **Size Down** to decrease the size of the wave.

#### **Changing the Speed of the Respiration Wave**

In RESP setup (see “Selecting the Respiration Setup” on page 181):

- Step 1.** Select **Resp Speed**. This defines the speed at which the wave is drawn across the screen in millimeters per second (mm/s).  
**Step 2.** Select the appropriate setting.

---

## Setting Up the Respiration Alarm

#### **Changing the Respiration Alarm Limits**

In RESP setup (see “Selecting the Respiration Setup” on page 181):

- Step 1.** Select **High Limit** if you want to set the upper alarm limit for the respiration rate.  
Select **Low Limit** if you want to set the lower alarm limit for the respiration rate.  
**Step 2.** Select the appropriate setting.

## Changing the Apnea Alarm Delay

In RESP setup (see “Selecting the Respiration Setup” on page 181):

- Step 1.** Select **Apnea** to set the time limit before the alarm is indicated if the patient stops breathing .
- Step 2.** Select the appropriate setting.

---



---

### Warning

---



---

**The safety and effectiveness of the respiration measurement method in the detection of apnea, particularly the apnea of prematurity and apnea of infancy, has not been established.**

---



---

## Enabling or Disabling Respiration and Apnea Alarms

In RESP setup (see “Selecting the Respiration Setup” on page 181):

- Step 3.** Select **Alarms** . This defines whether the alarms derived from the respiration signal are enabled.
- Step 4.** Select the appropriate setting

On	The alarms are enabled
Off	The alarms are disabled. The crossed bell symbol (X) will be displayed instead of the alarm limits.

## Troubleshooting the Respiration Measurement

### If the RR Numeric is Still being Displayed

Check at the top left of the screen for a technical alarm message (an INOP).

#### **RESP ERRATIC**

Make sure that the electrode is making good contact to the skin.

### If the RR Numeric Shows -?-

Check at the top left of the screen for a technical alarm message (an INOP).

#### **RESP EQUIP MALF**

Contact your biomedical department.  
The respiration electronics is faulty.

#### **RESP LEAD OFF**

Make sure that the patient cable is connected, the lead is connected to the electrode, and the electrode is attached.

# Measuring Non-invasive Blood Pressure (NBP)

This chapter covers measuring NBP and how to set up your NBP measurement.

At the end of the chapter you will find information on how to deal with common measurement problems (troubleshooting).

- Preparing to Measure NBP . . . . .188
- Starting and Stopping NBP Measurements... . . . .192
- Selecting the NBP Setup. . . . .197
- Switching the NBP Measurement On. . . . .197
- Setting Up the NBP Alarms . . . . .198
- Troubleshooting the NBP Measurement. . . . .200

---

## Preparing to Measure NBP

---

### **Warning**

**Before starting a NBP measurement, make sure that you have selected the correct patient size setting for your patient.**

---

---

---

### **Warning**

**Do not use the NBP cuff on a limb that has an intravenous infusion or catheter in place. This could cause tissue damage around the catheter when the infusion is slowed or blocked during cuff inflation.**

---

---

---

### **Warning**

**Non-invasive blood pressure measurements must not be performed on patients with sickle-cell disease or any condition where skin damage has occurred or is expected.**

---

---

---

### **Warning**

**Clinical judgement must be used to decide whether or not to perform frequent unattended blood pressure measurements on patients with severe blood clotting disorders because of the risk of hematoma in the limb fitted with the cuff.**

---

---

---

### **Warning**

**Inspect the application site frequently to ensure skin quality and inspect the extremity of the limb with the cuff for normal color, warmth and sensitivity. If the skin quality changes, or if the extremity circulation is being affected move the cuff to another site or stop the blood pressure measurements immediately.**

---

---

**Step 1.** Make sure that you can use NBP on the patient. The measurement needs a regular arterial pressure pulse, if this is hard to detect, the measurement becomes unreliable and the measurement time increases.

The following conditions interfere with the detection of the arterial pressure pulse:

**Patient Movement:** if the patient is moving, shivering or having convulsions.

**Cardiac Arrhythmias**

**Heart-lung machine.**

**Pressure changes:** if the patient's blood pressure is changing rapidly over the period of time during which the arterial pressure is being measured.

**Severe shock:** or hypothermia, where blood flow to the peripheries is reduced.

**Heart rate extremes:** measurements cannot be made at a heart rate less than 40bpm or greater than 300bpm

**Obesity:** a thick layer of fat surrounding a limb dampens the oscillations coming from the artery, and accuracy is reduced.

**Step 2.** Plug the air tubing into the NBP connector.

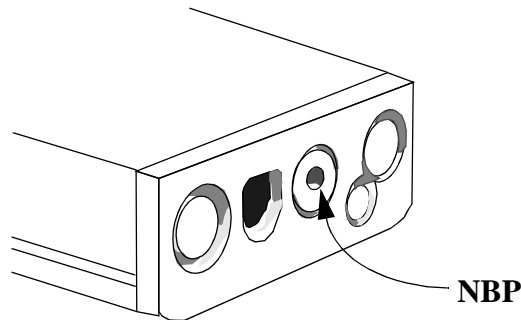

**Step 3.** Make sure that you are using the correct sized cuff.

The specified cuffs and tubings are defibrillator proof and can be used during electrosurgery.

**Long Life Reusable and Disposable Blood Pressure Cuffs<sup>a</sup>**

<b>Patient Category</b>	<b>Limb Circumference</b>	<b>Bladder Width</b>	<b>P/N Reusable</b>	<b>P/N Disposable</b>	<b>Tubing</b>
Infant	10 to 15cm	5.5cm	M1571A	M1874A	M1598B (1.5m) or M1599B (3m)
Pediatric	14 to 21.5cm	8cm	M1572A	M1875A	
Small Adult	20.5 to 28cm	10.5cm	M1573A	M1876A	
Adult	27 to 35cm	13cm	M1574A	M1877A	
Large Adult	34 to 43cm	16cm	M1575A	M1878A	
Adult (thigh)	42 to 54cm	20cm	M1576A	M1879A	

a. Always follow the specific instructions delivered with the cuff if this is possible. This information may be more recent than the information given here.

**Disposable Cuffs for Neonates/Infants<sup>a</sup>**

<b>Size</b>	<b>Limb Circumference</b>	<b>Bladder Width</b>	<b>Part Number</b>	<b>Tubing</b>
1	3.1 to 5.7cm	2.2cm	M1866A	M1596B (1.5m) or M1597B (3m)
2	4.3 to 8.0cm	2.8cm	M1868A	
3	5.8 to 10.9cm	3.9cm	M1870A	
4	7.1 to 13.1cm	4.7cm	M1872A	

a. Always follow the specific instructions delivered with the cuff if this is possible. This information may be more recent than the information given here.

The width of the cuff should be in the range from 37% to 47% of the limb circumference.



The inflatable part of the cuff should be long enough to encircle at least 80% of the limb.

The wrong size of cuff can cause inaccurate measurements.

**Step 4.** Apply the blood pressure cuff to the patient's arm or leg. The limb used for taking the measurement should be at the same level as the patient's heart. If this is not possible, you will have to correct the measurements (the corrections are given later, "Understanding the NBP Numerics" on page 196).

- Make sure that the cuff is completely deflated.
- Avoid placing the cuff on any extremity with an arterial catheter, or intravascular venous infusion line.
- Make sure that the arrow  (labelled 'ARTERIA') is over the correct artery.

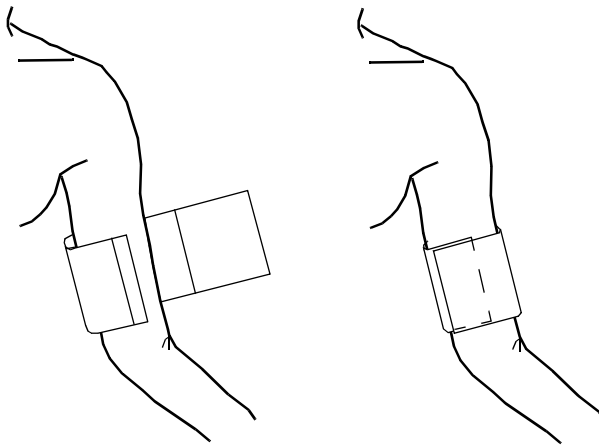

- Make sure that the cuff is not wrapped too tightly around the limb. If the cuff is too tight, it may cause discoloration, and possibly even ischemia of the extremities.
- Make sure that the edge of the cuff falls within the range marked <-> (on disposable cuffs the range is marked by a blue line without arrows). If it does not, use a better fitting cuff.

**Step 5.** Connect the cuff to the air tubing.

## Starting and Stopping NBP Measurements...

- Make sure that air can pass through the tubing, and that it is not squeezed or kinked, or in any way compressed or restricted.
- Inspect the application site regularly to ensure skin quality and inspect the extremity of the limb with the cuff for normal color, warmth and sensitivity. If the skin quality changes, or if the extremity circulation is being affected move the cuff to another site or stop the blood pressure measurements immediately. Check the application site more frequently if you are making automatic or STAT measurements.

---

### **Caution**

---

If liquid is spilled on the equipment or accessories, particularly if there is a chance that this liquid could get inside the tubing or the Measurement Server, contact your biomedical department

---

---

---

## **Starting and Stopping NBP Measurements...**

There are three types of NBP measurement:

- A single measurement.
- A repeated measurement where NBP is measured as many times as possible over a five minute period.
- An automatic measurement, where NBP is measured automatically at fixed intervals.

## Making a Single NBP Measurement

**Step 1.** Select NBP setup (see “Selecting the NBP Setup” on page 197)

**Step 2.** Make sure that manual measurement is enabled.

If it isn't

- a. Select **Auto/Man**. This enables or disables the manual measurement.
- b. Select the appropriate setting

Auto	NBP measurements will be made automatically, at fixed intervals. The time between measurements is set by the Repeat Time. <i>Note</i> —Selecting Auto does not start the measurement cycle.
Manual	NBP measurements are started by the user.

**Step 3.** To start an NBP measurement

- press the **Start/Stop** key on the Measurement Server (note that this key may have been disabled by your biomedical engineer), **or**
- press the **Start/Stop** SmartKey on the monitor (you may have to press ◀ or ▶ to find this SmartKey, if it is configured), **or**
- select **Start/Stop NBP** in NBP Setup (see “Selecting the NBP Setup” on page 197).



To stop the current measurement immediately:

- press the **Start/Stop** SmartKey, **or**
- press the **Start/Stop** key on the Measurement Server again, **or**
- press the **Stop All** SmartKey.
- select **Start/Stop NBP** in NBP Setup (see “Selecting the NBP Setup” on page 197).



## Making STAT NBP Measurements

**Note:** Prolonged series of repeating non-invasive blood pressure measurements can cause purpura, ischemia and neuropathy in the limb with the cuff.

To start a repeating NBP measurement

- press the “**NBP STAT**” SmartKey on the monitor (you may have to press ◀ or ▶ to find this SmartKey, if it is configured), **or**



## Starting and Stopping NBP Measurements...

- select “**Start/Stop STAT**” in NBP Setup (see “Selecting the NBP Setup” on page 197).

To stop the measurement immediately,

- press the “**NBP STAT**” SmartKey again, or
- press the **Start/Stop** SmartKey, or
- press the **Start/Stop** key on the Measurement Server, or
- press **Start/Stop NBP** in the NBP Setup menu.
- press the **Stop All** SmartKey.



## Making Automatic NBP Measurements

Note: Prolonged series of automatic non-invasive blood pressure measurements can cause purpura, ischemia and neuropathy in the limb with the cuff.

**Step 1.** Select NBP setup (see “Selecting the NBP Setup” on page 197)

**Step 2.** Make sure that automatic measurement is enabled.

If it isn't:

- a. Select **Auto/Man**. This enables or disables the automatic measurement.
- b. Select the appropriate setting.

Auto	NBP measurements will be made automatically, at fixed intervals. The time between measurements is set by the Repeat Time. <i>Note</i> —Selecting Auto does not start the measurement cycle.
Manual	NBP measurements are started by the user.

**Step 3.** Make sure the repeat time is correct.

If it isn't

- a. Select **Repeat Time**. This defines the time between two automatic measurements. The time is between the start of one measurement and the start of the next.
- b. Select the appropriate setting.

**Step 4.** To start the automatic NBP measurement

- press the “**Start/Stop**” key on the Measurement Server (note that this key might have been disabled by your biomedical engineer), or

- press the “**Start/Stop**” SmartKey on the monitor (you may have to press ◀ or ▶ to find this SmartKey, if it is configured), or
- select “**Start/Stop NBP**” in NBP Setup (see “Selecting the NBP Setup” on page 197).



While the automatic NBP measurement is active, the repeat time is displayed beside the measurement mode (see “Understanding the NBP Numerics” on page 196)

To stop the current measurement immediately,

- press the **Start/Stop** SmartKey,
- press the **Start/Stop** key again, or
- reselect **Start/Stop NBP** in the NBP Setup menu.

To stop the automatic measurement cycle altogether, press the **Stop All** SmartKey.



If you change the QuickSet or patient category, any currently active automatic NBP measurement and cycle will be stopped.

## Using the NBP Cuff to Occlude Blood Vessels

The NBP cuff can be used to occlude the vessels of a patient’s limb to allow a vein to be punctured and blood samples to be drawn. To start cuff inflation:

**Step 1.** Select NBP Setup (see “Selecting the NBP Setup” on page 197)

**Step 2.** Select **Venipuncture**.

**Step 3.** Puncture vein and draw blood sample.

**Step 4.** Select **Venipuncture** again to deflate the cuff.

OR

**Step 1.** Press the **Venipuncture** SmartKey.

**Step 2.** Puncture vein and draw blood sample.

**Step 3.** Press the Smartkey again to deflate the cuff.



## Starting and Stopping NBP Measurements...

During venipuncture, the NBP display shows the inflation pressure of the cuff.

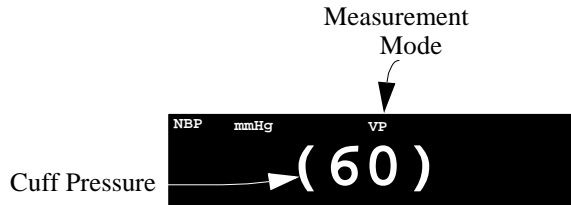

The cuff will deflate automatically after a set time (adult/pediatric 170 seconds, neonatal 85 seconds) if you do not deflate it.

## Understanding the NBP Numerics

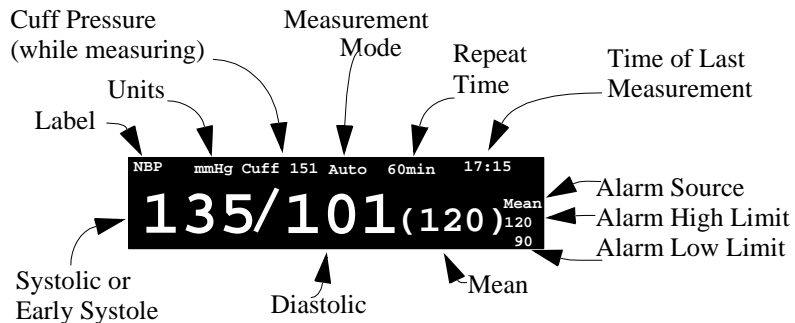

**Note:** Depending on the size of the NBP numeric, not all of the elements shown above may be visible.

If you have set up parallel alarm sources, the selected sources are displayed instead of the alarm limits.

The pressure in the cuff is displayed instead of the units and the repeat time, while the measurement is being made.

An early systolic value is displayed alone, at an early stage in the measurement to give you a preliminary indication of the systolic blood pressure.

- If the cuff is placed higher than the heart level,
  - add 0.75mmHg (0.10kPa) to the displayed value for each centimeter difference
  - add 1.9mmHg (0.25kPa) for each inch difference.
- If the cuff is placed lower than the heart level,
  - deduct 0.75mmHg (0.10kPa) from the displayed value for each centimeter difference or
  - deduct 1.9mmHg (0.25kPa) for each inch difference.

Electro-surgical equipment may distort the measured NBP values, but does not affect the safety of the patient or the equipment.

During defibrillation, the NBP values may be temporarily interrupted or distorted. After defibrillation, the monitor will continue to monitor as before; the operating mode and user settings are not affected.

## Selecting the NBP Setup

**Step 1.** Highlight the NBP numeric and press on the TouchStrip.  
OR

**Step 1.** Press the **Setup** key.

**Step 2.** Move the highlight to “NBP”.

**Step 3.** Press on the TouchStrip.

When you are finished with the NBP Setup, press the **Main Screen** key.

## Switching the NBP Measurement On

In NBP setup (see “Selecting the NBP Setup” on page 197):

**Step 1.** Select **NBP On/Off**. This defines whether NBP is to be measured or not.

**Step 2.** Select the appropriate setting:

On	NBP measurements can be made.
Off	NBP measurements cannot be made.

## Setting Up the NBP Alarms

### Changing the alarm limits.

In NBP setup (see “Selecting the NBP Setup” on page 197):

**Step 1.** Select **Alarms from.** to define the measurement for which the alarm limits are being set.

**Step 2.** Select one of the following:

<b>sys</b>	Use this when you want to monitor the systolic pressure for alarm conditions.
<b>dia</b>	Use this when you want to monitor the diastolic pressure for alarm conditions.
<b>mean</b>	Use this when you want to monitor the mean pressure for alarm conditions.
<b>Sys&amp;Dia</b>	Use this when you want to monitor the systolic and diastolic pressures in parallel for alarm conditions Only one alarm will be given at any time, systolic pressure alarm conditions will have priority.
<b>Dia&amp;Mean</b>	Use this when you want to monitor the diastolic and mean pressures in parallel for alarm conditions. Only one alarm will be given at any time, mean pressure alarm conditions will have priority.
<b>Sys&amp;Mean</b>	Use this when you want to monitor the systolic and mean pressures in parallel for alarm conditions. Only one alarm will be given at any time, mean pressure alarm conditions will have priority.
<b>S&amp;D&amp;M</b>	Use this when you want to monitor all three pressures in parallel for alarm conditions. Only one alarm will be given at any time, mean pressure alarm conditions will have priority over all, systolic pressure alarm conditions will have priority over diastolic pressure alarm conditions.

Select and set the **High Limit and Low Limit** for the pressure(s) you have selected.



The alarm limit ranges are the same as the measurement ranges given in the table below.

	<b>Adult</b>	<b>Pediatric</b>	<b>Neonatal</b>
Systolic Measurement and Alarm Limit Range	30 to 270mmHg (4.0 to 36.0kPa)	30 to 180mmHg (4.0 to 24.0kPa)	30 to 130mmHg (4.0 to 17.0kPa)
Diastolic Measurement and Alarm Limit Range	10 to 245mmHg (1.5 to 32.0kPa)	10 to 150mmHg (1.5 to 20.0kPa)	10 to 100mmHg (1.5 to 13.0kPa)
Mean Measurement and Alarm Limit Range	20 to 255mmHg (2.5 to 34.0kPa)	20 to 160mmHg (2.5 to 21.0kPa)	20 to 120mmHg (2.5 to 16.0kPa)
Overpressure Safety Limits (for more than 2 seconds)	max. 300mmHg (40.0kPa)	max. 300mmHg (40.0kPa)	max. 150mmHg (20.0kPa)
Heart Rate	40 to 300bpm	40 to 300bpm	40 to 300bpm

## Enabling the alarms

In NBP setup (see “Selecting the NBP Setup” on page 197):

**Step 1.** Select **Alarms**. This defines whether the pressure alarms derived from selected measurement are enabled.

**Step 2.** Select the appropriate setting.

On	The alarms are enabled
Off	The alarms are disabled. The crossed bell symbol ( <del>🔔</del> ) will be displayed instead of the alarm limits.

## Troubleshooting the NBP Measurement

### If the NBP Numeric Shows -?-

Check at the top left of the screen for a technical alarm message (an INOP).

#### **CUFF NOT DEFLATED**

Disconnect the cuff from the Measurement Server, or remove from the patient.

You can Silence the INOP, but it remains until the next measurement is started or the **Stop All** SmartKey is pressed.

*Note*—This INOP arises when:

*Adult or pediatric patients:* The NBP cuff pressure has been greater than 15mmHg (2kPa) for more than 3 minutes.

*Neonatal patients:* The NBP cuff pressure has been greater than 5mmHg (0.7kPa) for more than 1.5 minutes.

#### **NBP CUFF OVERPRESS**

Disconnect the cuff from the Measurement Server, or remove from the patient. Make sure that the rubber tube to the NBP cuff is not kinked.

You can Silence the INOP, but it remains until the next measurement is started or the **Stop All** SmartKey is pressed.

*Note*—This INOP arises when NBP cuff pressure increased above overpressure safety limits.

**NBP EQUIP MALF**

Make sure that the rubber tube to the NBP cuff, or the cuff itself, is not kinked. Check the tubing and cuff for leakages.

If it is NOT kinked and there are no leaks, contact your biomedical department. The NBP hardware is faulty.

You can Silence the INOP, but it remains until the next measurement is started or the **Stop All** SmartKey is pressed.

**NBP INTERRUPTED**

Check the tubing and cuff for leakages. Try repeating the measurement.

If the INOP occurs repeatedly, contact your biomedical department.

You can Silence the INOP, but it remains until the next measurement is started or the **Stop All** SmartKey is pressed.

*Note*—This INOP arises when the measurement needed longer than the maximum time for inflation, deflation or the total measurement.

**NBP MEASURE FAILED**

Check that the patient category on the monitor is correct.

Check the condition and suitability of the patient (see “Preparing to Measure NBP” on page 188).

You can Silence the INOP, but it remains until the next measurement is started or the **Stop All** SmartKey is pressed.

*Note*—This INOP arises when no values could be measured.



# Measuring Pressure, Invasively (PRESS)

This chapter covers measuring invasive pressure and how to set up your invasive pressure measurement.

At the end of the chapter you will find information on how to deal with common measurement problems (troubleshooting).

- Preparing to Measure Pressure . . . . .204
- Selecting the Pressure Setup . . . . .209
- Switching the Pressure Measurement On . . . . .209
- Setting Up the Pressure Wave . . . . .210
- Setting Up the PRESS Alarms . . . . .211
- Calibrating a Disposable Transducer (M1567A/M1568A) . . . . .213
- Calibrating a CPJ840J6 Transducer . . . . .214
- Troubleshooting the Pressure Measurement. . . . .218

---

## Preparing to Measure Pressure

---

### **Caution**

---

Use only pressure transducers listed in “PRESS Accessories” on page 434.

---

The specified transducers are designed to have special protection against electric shocks (particularly regarding allowable leakage currents), and are defibrillator proof and can be used during electrosurgery.

*Note*—The pressure values may be temporarily interrupted or distorted when a patient is being defibrillated. Normal monitoring continues after defibrillation. The operating mode and user settings are not affected.

Whenever you begin using a reusable transducer, or at regular intervals according to the schedule in your Hospital Procedures Policy, have your biomedical engineering department do a mercury calibration. How to do a mercury calibration is described in “Calibrating a CPJ840J6 Transducer” on page 214.

---

### **Warning**

---

**Disposable pressure transducers are not to be reused.**

---

**Step 1.** Plug the pressure cable into the M3001A Measurement Server or M3015A/M3016A Measurement Server Extension.

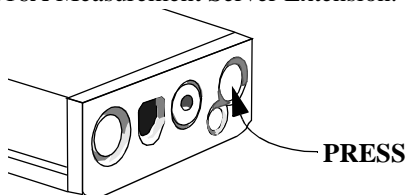

*Note*—With each M3001A Measurement Server or Measurement Server Extension you can measure either invasive pressure or temperature. These measurements cannot be measured at the same time in one Server or Server Extension.

**Step 2.** Prepare the pressure line and transducer by flushing the system with the solution to be infused.

Make sure that the system is free of air bubbles.

**Step 3.** Connect the patient catheter to the pressure line.

Make sure that there is no air present in the catheter, line or transducer dome.

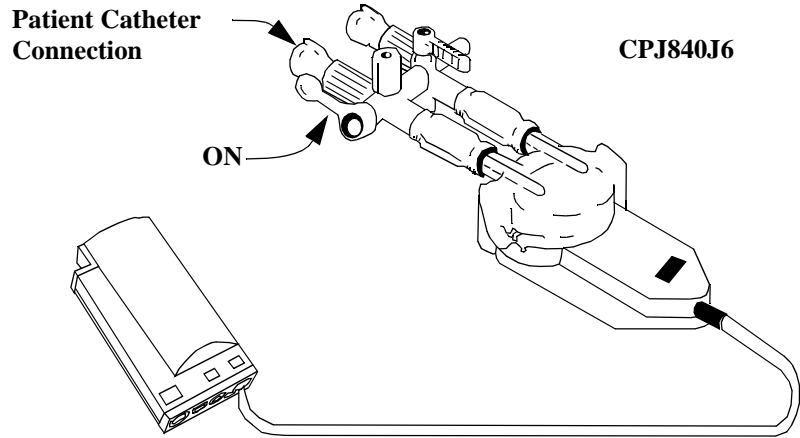

---

**Caution**

---

If air bubbles appear in the pressure line or transducer, flush the system with the solution to be infused again.

---

---

**Step 4.** If you are using an infusion pressure cuff with the pressure line, attach the pressure cuff to the fluid to be infused and inflate it according to your standard hospital procedure, then start the infusion.

**Step 5.** Position the transducer so that it is level with the heart, approximately at the level of the midaxillary line.

## Selecting a Label (and the Label Dependent Settings)

**Step 1.** Make sure the correct label has been selected.

*Note*—The label automatically uses the scales, color, and alarm limits and other settings for that label.

The settings for pulse derived from the pressure measurement are not affected by changing the label.

If more than one pressure is measured, labels that are assigned to one pressure channel cannot be selected for the other pressure channel to avoid duplicate labels.

From the pressure setup menu (see “Selecting the Pressure Setup” on page 209)

- a. Select **Label**.
- b. Select the appropriate setting:

<b>Label</b>	<b>Description</b>
PI	Non-specific pressure label.
ABP	Arterial Blood Pressure
ART	Arterial Blood Pressure
Ao	Aortic Pressure
CVP	Central Venous Pressure
ICP	Intracranial Pressure
LAP	Left Atrial Pressure
PAP	Pulmonary Artery Pressure
RAP	Right Atrial Pressure
UAP	Umbilical Arterial Pressure
UVP	Umbilical Venous Pressure

The label list contains only entries that are selectable, so the user cannot create a label conflict by changing the label. The only way to create a label conflict (duplicate labels) is to connect a Measurement Server Extension to a Measurement Server with the same label. If there is a label conflict, one of the pressures stays off, even if there is a transducer connected, and the status message “Change label ABP of pressure 1” appears.



---

**Caution**

---

If liquid (other than the solution used to infuse the pressure line and transducer) is spilled on the equipment or accessories, particularly if there is a chance that this liquid could get inside the transducer or the Measurement Server, contact your biomedical department.

---

---

**Zeroing the Transducer**

If you are measuring intracranial pressure, you should perform your zero (and calibration) after you have connected the transducer, and before you connect the patient catheter to the pressure line (the most recent zero and calibration are stored in the M3001A Measurement Server or the M3015A/M3016A Measurement Server Extension and will be used automatically).

---

**Warning**

---

**Invasive pressure alarms (and pulse alarms, if these are being derived from the invasive pressure) are turned off while the transducer is zeroing. The alarms turn back on 30 seconds after the zeroing is finished.**

---

---

---

**Warning**

---

**Zero the invasive pressure transducer before starting the measurement, if the patient is moved, and at least once a day. (You can find the date and time of the last zero by highlighting and holding the Zero SmartKey, without pressing, on the monitor, or holding the highlight on “Zero” in the PRESS Setup menu, without pressing). If you do not zero the transducer frequently there will not be a valid zero for the instrument to use and the pressure readings will not be accurate.**

---

---

**Step 2.** Zero the transducer.

- a. Turn off the patient stopcock.
- b. Vent the transducer to atmospheric pressure.
- c. Press the **ZERO** key on the Measurement Server (note that this key might have been disabled by your biomedical engineer),

OR

Highlight and select Zero in the PRESS Setup menu.



OR

Press the **Zero** SmartKey on the monitor (you may have to press ◀◀ or ▶▶ to find this SmartKey, if it is configured).

**Note:** If you have a Measurement Server Extension (M3015A or M3016A) connected, using the **Zero** SmartKey or the **ZERO** key on the Measurement Server will zero both pressures if they are switched on.

---

---

**Warning**

**Before using the Zero SmartKey or the ZERO key on the Measurement Server to zero both pressures, make sure that both pressure transducers are vented to atmospheric pressure.**

**As the Zero SmartKey or the ZERO key on the Measurement Server zeroes all connected pressures, a non-pulsatile pressure such as CVP could otherwise be inadvertently zeroed, which would lead to wrong pressure readings.**

---

---

When the prompt tone and the message *PRESS zero done at date and time* appear, close the stopcock to atmospheric pressure, and open the stopcock to the patient.

If the zero does not complete successfully there are a number of possible causes. The probable cause is listed just above the SmartKeys:

- |   |   |
|---|---|
| <b>unable to zero - equipment malfunction</b> | If this message persists contact your biomedical department. The pressure hardware is faulty.   |
| <b>unable to zero - excessive offset</b>      | Make sure that there is no pressure applied to the transducer (zero can only be performed if the applied pressure is between -200mmHg and 200mmHg (-26kPa and 26kPa)).<br><br>If this does not work, replace the transducer and contact your biomedical department. |
| <b>unable to zero - no transducer</b>         | Make sure that the transducer is connected and try again.   |
| <b>unable to zero - pulsatile pressure</b>    | Make sure that the transducer is not connected to the patient, that the stopcock is open to the atmosphere, and try again.  |

- unable to zero - timed out** Try pressing the Zero key again.  
If this does not work, replace the transducer and contact your biomedical department.
- unable to zero - unstable signal** Make sure there are no disturbances to the transducer, and repeat the zeroing.

## Selecting the Pressure Setup

**Step 1.** Highlight the PRESS numeric and press on the TouchStrip.  
OR

**Step 1.** Press the **Setup** key.

**Step 2.** Move the highlight to pressure label (e.g. ABP, PAP,...).

**Step 3.** Press on the TouchStrip.

When you are finished with the PRESS Setup, press the **Main Screen** key.

## Switching the Pressure Measurement On

The pressure measurement is switched on automatically when you plug in the pressure transducer.

If the transducer is connected, you can switch the measurement on or off in the pressure setup (see “Selecting the Pressure Setup” on page 209):

**Step 1.** Select **PRESS On/Off**. This defines whether the pressure is to be measured or not.

**Step 2.** Select the appropriate setting:

On	The pressure will be measured. You can only switch the pressure on if a transducer is connected.
Off	The pressure will not be measured. <i>Note</i> —If the pulse is being generated from the pressure, this will not be measured either.

If you get a prompt message saying **PRESS equip malf - cannot switch on**, you should contact your biomedical department. The pressure hardware is faulty.

---

## Setting Up the Pressure Wave

See “Selecting a Wave for the Screen” on page 44 for information on how to get the pressure wave onto the screen.

### Changing the Size of the Pressure Wave

In the pressure Setup (see “Selecting the Pressure Setup” on page 209):

**Step 1.** Make sure the correct label has been selected. The scale you set is valid only for that label.

**Step 2.** Select **scale** to set the size of the axis for the wave.

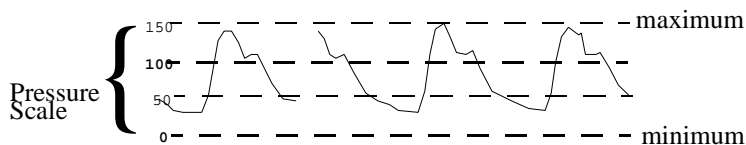

Select the appropriate setting you want for the scale. The choices range from -20 mmHg to 300 mmHg.

- A positive value sets the top gridline. The bottom gridline is set at zero.
- A negative value sets the bottom gridline. The middle gridline is set at zero.

### Optimizing the Waveform

In the pressure Setup (see “Selecting the Pressure Setup” on page 209):

- Select **Optimum scale** to let the monitor select the best scale for the current wave. Both the minimum and maximum are set automatically by **Optimum scale**. Selecting **Optimum scale** again re-optimizes the scale.

## Non-Physiological Artifact Suppression

Some clinical procedures may affect blood pressure, for example, a flush procedure or a blood sample. Your monitor may be configured to suppress these non-physiological artifacts for a specified duration (**ArtifSuppr**) is configured to 30, 60, or 90 seconds). The monitor shows the INOP message **<Pressure label> ARTIFACT** and high limit alarms are suppressed during the configured period.

## Changing the Speed of the Pressure Wave

The speed of the pressure wave is the same as the speed for the ECG wave.

In the pressure Setup (see “Selecting the Pressure Setup” on page 209):

**Step 1.** Select **Speed**. This defines the speed at which all of the waves (with the exception of respiratory waves) are drawn across the screen, in millimeters per second (mm/s).

**Step 2.** Select the speed.

---

## Setting Up the PRESS Alarms

### Changing the alarm limits.

In PRESS setup (see “Selecting the Pressure Setup” on page 209):

---

#### **Warning**

---

**Make sure the correct label has been selected before you set the alarm limits.**

**The alarm limits you set are valid only for the current label. Changing the label could change the alarm limits.**

---

**Step 1.** Select **Alarms from** to define the measurement for which the alarm limits are being set.

**Step 2.** Select one of the following:

Sys	Use this when you want to monitor the systolic pressure for alarm conditions.
Dia	Use this when you want to monitor the diastolic pressure for alarm conditions.
Mean	Use this when you want to monitor the mean pressure for alarm conditions.
Sys&Dia	Use this when you want to monitor the systolic and diastolic pressures in parallel for alarm conditions Only one alarm is given at any time, systolic pressure alarm conditions will have priority.
Dia&Mean	Use this when you want to monitor the diastolic and mean pressures in parallel for alarm conditions. Only one alarm is given at any time, mean pressure alarm conditions will have priority.
Sys&Mean	Use this when you want to monitor the systolic and mean pressures in parallel for alarm conditions. Only one alarm is given at any time, mean pressure alarm conditions will have priority.
S&D&M	Use this when you want to monitor all three pressures in parallel for alarm conditions. Only one alarm is given at any time, mean pressure alarm conditions will have priority over all, systolic pressure alarm conditions will have priority over diastolic pressure alarm conditions.

**Step 3.** Select and set the **High Limit** and **Low Limit** for the pressure(s) you have selected.

## Enabling the alarms

In PRESS setup (see “Selecting the Pressure Setup” on page 209):

**Step 1.** Select **Alarms**. This defines whether the pressure alarms derived from selected measurement are enabled.

**Step 2.** Select the appropriate setting.

On	The alarms are enabled
Off	The alarms are disabled. The crossed bell symbol ( <del>🔔</del> ) will be displayed instead of the alarm limits.

**Setting  
PRESS as  
the source  
for the Pulse**

See “Selecting the Source for the Heart Rate Numeric” on page 132, and “Changing the Heart Rate Alarm Limits” on page 134.

**Calibrating a Disposable Transducer (M1567A/M1568A)**

(M1567A and M1568A are not available for use in the USA.)

Calibrating transducers can only be enabled and disabled by the biomedical engineering department. See “Enabling PRESS Transducer Calibration” on page 363.

**Entering a  
Known  
Calibration  
Factor**

The calibration factor for disposable transducers should be indicated on the transducer.

Select the pressure setup by moving the highlight to the PRESS numeric and pressing on the TouchStrip.

**Step 1.** Zero the transducer.

- a. Turn off the patient stopcock.
- b. Vent the transducer to atmospheric pressure.
- c. Press the **ZERO** key on the Measurement Server

OR

Press the Zero key on the monitor.

- d. When the prompt tone and the message *PRESS zero done at date and time* appear, close the stopcock to atmospheric pressure
- e. Make sure that the connection that would lead to the patient is off.

**Step 2.** Select **Cal. Factor** from the menu.

**Step 3.** Select the calibration factor of the transducer from the list.

**Step 4.** Press the confirm softkey.

When the prompt tone and the message *PRESS calibration done at date and time* appear, you can start measuring again.

---

## Calibrating a CPJ840J6 Transducer

A mercury calibration should be done by the biomedical engineering department when a new transducer is used. You can find the date and time of the last calibration by highlighting **Cal. Press** or **Cal. Factor** in the pressure Setup window (if you cannot select either of these, zero the transducer and try again).

Calibrating transducers can only be enabled and disabled by the biomedical engineering department. See “Enabling PRESS Transducer Calibration” on page 363.

If you already know the calibration factor for the transducer, enter it as described in “Entering a Known Calibration Factor” on page 213.



## Doing a Mercury Calibration

To do this calibration, you will need

- A standard sphygmomanometer.
- A sterile 10cc syringe with heparinised solution.
- A 3-way stopcock.
- Approximately 25cm of tubing.

---

### Warning

---

**Never perform the invasive pressure calibration while a patient is being measured.**

---

---

**Step 1.** Zero the transducer.

- Turn off the patient stopcock.
- Vent the transducer to atmospheric pressure.
- Press the **ZERO** key on the Measurement Server

OR

Press the Zero SmartKey on the monitor. **Note:** If you have a Measurement Server Extension connected, using the SmartKey or the **ZERO** key on the Measurement Server will zero both pressures if they are switched on.

- When the prompt tone and the message *PRESS zero done at date and time* appear, close the stopcock to atmospheric pressure
- Make sure that the connection that would lead to the patient is off.

**Step 2.** Connect the syringe and manometer.

- a. Attach the tubing to the manometer.
- b. Connect the 3-way stopcock to the stopcock that would not be connected to the patient catheter when you were measuring a patient.
- c. Attach the syringe to one port
- d. Attach the tubing from the manometer to the other port.
- e. Open the port to the manometer.

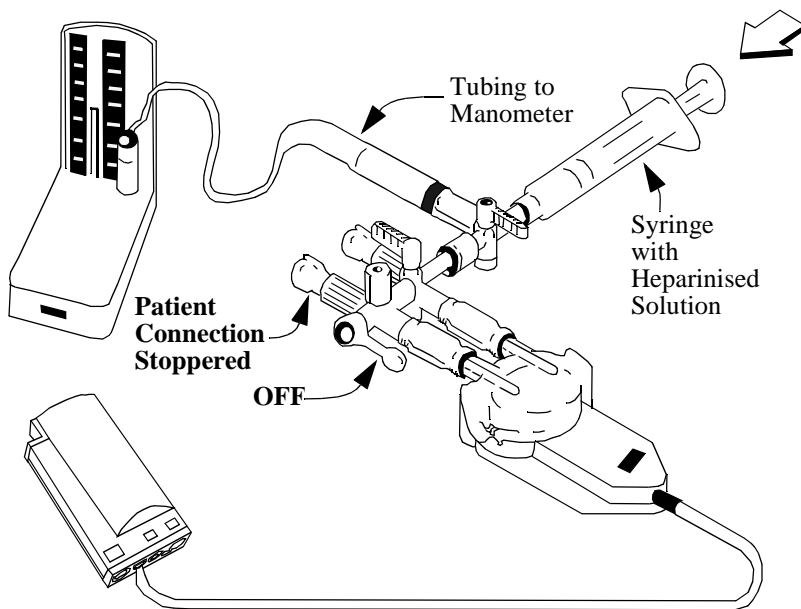

**Step 3.** Move the syringe barrel in and raise the mercury to 200mmHg (30kPa). (200mmHg is the recommended calibration pressure. You can use any calibration pressures from the list given under **Cal. Press**)

**Step 4.** Recalculate the calibration factor.

- a. Select the pressure setup by moving the highlight to the PRESS numeric and pressing on the strip.
- b. Select **Cal. Press.** from the menu.
- c. Select the calibration pressure from the list.
- d. Press the confirm softkey.

**Step 5.** When the prompt tone and the message *PRESS calibration done at date and time* appear, remove the manometer tubing, syringe and extra stopcock.

**Step 6.** It is recommended that you replace the dome and tubing of the transducer with sterile ones.

**Step 7.** Reconnect the patient and start measuring again.

There are a number of possible reasons why the calibration might not complete successfully. The probable cause is listed just above the SmartKeys:

<b>unable to calibrate - equipment malfunction</b>	If this message persists contact your biomedical department. The pressure hardware is faulty.
<b>unable to calibrate - out of range</b>	Make sure that you have selected the value for <b>Cal. Press</b> that you are applying to the transducer, and repeat the calibration.
<b>unable to calibrate - no transducer</b>	Make sure that the transducer is connected and try again.
<b>unable to calibrate - unstable signal</b>	Make sure there are no disturbances to the transducer, and repeat the calibration.

## Troubleshooting the Pressure Measurement

### If the Pressure Numeric is Displayed

Check at the top left of the screen for a technical alarm message (an INOP).

**PRESS<sup>1</sup> REDUCE SIZE**      Increase the scale for the pressure wave. (see “Changing the Size of the Pressure Wave” on page 210).

**PRESS<sup>1</sup> ARTIFACT**      A non-physiological event is detected (for example, a flush or blood sample). Artifact suppression is configured (to 30, 60 or 90 seconds) and high limit alarms are suppressed during the configured period.

<sup>1</sup>PRESS is replaced by the selected pressure label.

### If the Pressure and Pulse Numerics Show -?-

Check at the top left of the screen for a technical alarm message (an INOP).

**PRESS<sup>1</sup> EQUIP MALF**      If this message persists contact your biomedical department. The pressure hardware is faulty.

**PRESS<sup>1</sup> NO TRANSDUCER**      Make sure that the pressure transducer is connected to the Measurement Server.

If you Silence this INOP, the measurement (and the pulse if it is derived from the pressure) will be switched off.

**PRESS<sup>1</sup> OVERRANGE**      Make sure that the measurement has been properly prepared and zeroed, and that the transducer is level with the heart (see “Preparing to Measure Pressure” on page 204).

*Note*—This INOP arises when the pressure measured was greater than 361mmHg or less than -41mmHg

**PRESS<sup>1</sup> ZERO + CHECK CAL** Perform a zero (see “Zeroing the Transducer” on page 207), and check the calibration of the transducer (see “Calibrating a CPJ840J6 Transducer” on page 214).

<sup>1</sup>PRESS is replaced by the selected pressure label.

### If the Pulse Numeric Shows -?-

- If the pulse is being derived from an SpO<sub>2</sub> measurement, see “If the Pulse Numeric Shows -?-” on page 234.
- If the pulse is being derived from an ECG measurement, see “If the HR Numeric Shows -?-” on page 144.

If the pulse is being derived from an invasive pressure measurement: Check at the top left of the screen for a technical alarm message (an INOP).

**PRESS<sup>1</sup> NOISY SIGNAL** Change the source for the pulse to SpO<sub>2</sub> or ECG (see “Selecting the Source for the Heart Rate Numeric” on page 132).

*Note*—This INOP arises when the pulse detector finds a pulse rate above 350bpm.

**PRESS<sup>1</sup> NON-PULSATILE** Change the source for the pulse to SpO<sub>2</sub> or ECG (see “Selecting the Source for the Heart Rate Numeric” on page 132).

*Note*—This INOP arises when the pressure being measured is less than 25 beats per minute.

<sup>1</sup>PRESS is replaced by the selected pressure label.

## Troubleshooting the Pressure Measurement

# Measuring the Oxygen Saturation of Arterial Blood (SpO<sub>2</sub>)

This chapter covers measuring SpO<sub>2</sub> and how to set up your SpO<sub>2</sub> measurement.

At the end of the chapter you will find information on how to deal with common measurement problems (troubleshooting)

- Preparing and Measuring SpO<sub>2</sub> .....222
- Selecting the SpO<sub>2</sub> Setup .....229
- Switching the SpO<sub>2</sub> Measurement On .....229
- Setting Up the Tone Modulation .....230
- Setting Up the SpO<sub>2</sub> Alarms. ....231
- Setting Up the Pleth Wave .....233
- Troubleshooting the SpO<sub>2</sub>/PLETH Measurement .....234

## Preparing and Measuring SpO<sub>2</sub>

The SpO<sub>2</sub> parameter measures the functional arterial oxygen saturation. That is, the percentage of oxygenated hemoglobin in relation to the sum of oxyhemoglobin and deoxyhemoglobin.

---

### Caution

---

Always handle the  $\mu$ transducer and cable with care. The transducer has sensitive electronic components in it that can be damaged by harsh treatment. Always protect the cable from sharp edged objects.

Wear and tear due to patient movement and normal transducer cleaning mean that the SpO<sub>2</sub> transducers have a limited lifetime. If you handle your transducer with care, you can expect to be able to use it for up to two years. Philips Medical Systems' warranty agreement does not apply to defects arising from improper use.

---

---

---

### Warning

---

- 1. Using an SpO<sub>2</sub> transducer during MR imaging can cause severe burns. To minimize this risk, ensure that the cable is positioned so that no inductive loops are formed. If the transducer does not appear to be operating properly, remove it immediately from the patient.**
  - 2. Never apply an SpO<sub>2</sub> transducer at ambient temperatures higher than 37°C because this can cause severe burns after prolonged application.**
- 
- 

---

### Caution

---

1. Injected dyes, such as methylene blue, or intravascular dyshemoglobins, such as methemoglobin, may lead to inaccurate measurements.
  2. The “patient category” setting of the monitor is used to optimize the calculation of the SpO<sub>2</sub> and Pulse numerics. Check the correct patient category setting (adult/pediatric and neonatal) before using the SpO<sub>2</sub> measurement to avoid inaccurate readings
  3. Known possible sources of interference are:
    - high levels of ambient light
    - excessive patient movement and vibration
    - electromagnetic interference
- 
-



**Step 1.** Select the correct type and size of transducer from the chart (no other transducers may be used).

**Caution**

Use only SpO<sub>2</sub> transducers listed in “SpO<sub>2</sub> Accessories” on page 429.

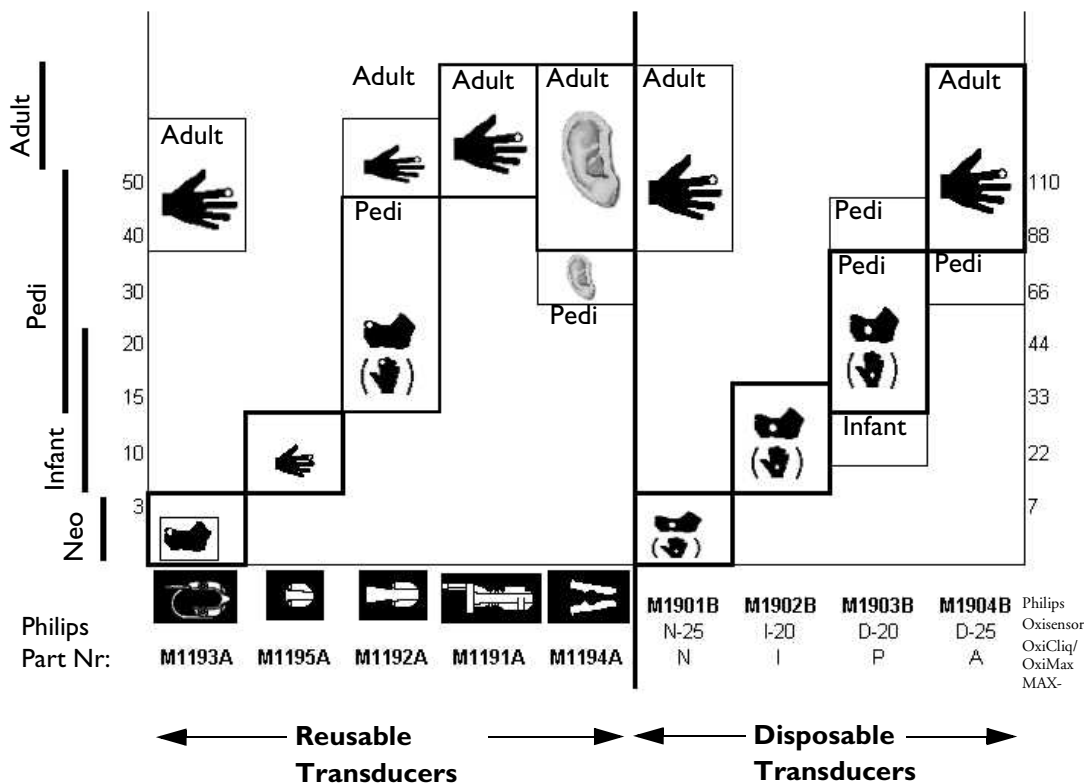

**Best Choice**

**Good Choice**

Find the patient’s weight on the vertical axis of the chart. The heavy-bordered areas at this weight indicate that the transducer on the horizontal axis is a “best choice” for this patient. The areas with light borders indicate a “good choice”. The recommended application site is shown as a white dot in the picture.

*For example*, the best reusable transducer for 35kg pediatric is the M1192A, applied to the toe or finger. Alternatively, you could use M1194A applied to the ear.

The two types of transducer are:

- |                   |  |
|-------------------|--|
| <b>Disposable</b> | Disposable transducers must not be reused on different patients. They can be reused/relocated on the same patient. |
| <b>Reusable</b>   | These can be reused on different patients after being disinfected (see “SpO <sub>2</sub> Transducer” on page 295). |

See “SpO<sub>2</sub> Accessories” on page 429 for a list of the transducers and accessories.

---

---

**Warning**

---

---

**Do not use OxiCliq disposable transducers in a high humidity environment, such as in neonatal incubators or in the presence of fluids, which may contaminate transducer and electrical connections causing unreliable or intermittent measurements.**

---

---

**Step 2.** If you have selected a disposable transducer, remove the protective backing.

---

---

**Warning**

---

---

**Do not use disposable transducers on patients who have allergic reactions to the adhesive.**

---

---

**Step 3.** Apply the transducer to the appropriate part of the patient’s body. If possible, position the transducer at the same height as the heart. Failure to apply the transducer correctly may cause incorrect measurements.

---

**Warning**

---

1. Avoid placing the transducer on any extremity with an arterial catheter, or intravascular venous infusion line.
  2. Make sure the light emitter and the photo detector are directly opposite each other and that all of the light from the emitter passes through the patients tissue.
  3. For Neonatal patients, make sure the adapter cable for disposable transducers is outside the incubator. (The humid atmosphere inside the incubator can cause inaccurate measurements).
- 

- Remove colored nail polish from the application site.
- Make sure there is a pulsatile flow present at the application site.
- Make sure the site is not subject to vibration or excessive motion.
- Make sure that the application site is neither too thick, nor too thin. If this is the case you will get an “SpO<sub>2</sub> Non-Pulsatile” INOP message.
- Using the transducer in the presence of bright lights may result in inaccurate measurements. In such cases, cover the site with an opaque material.
- Keep power cables away from the transducer cable and connector. (Electrical interference can cause inaccurate SpO<sub>2</sub> and Pulse rate measurements, or INOPs).

Follow the SpO<sub>2</sub> transducer’s instructions for use, adhering to all warnings and cautions.

Descriptions for how to apply the reusable transducers are given below.

**Step 4.** Attach the transducer cable to the Measurement Server (M3001A).

For disposable transducers, plug the transducer into the adapter cable and plug this cable into the Measurement Server.

For reusable transducers, plug the transducer directly into the Measurement Server.

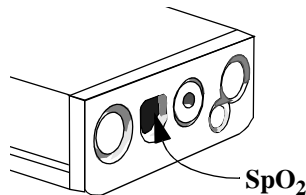

---

**Caution**

---

Do not use more than 1 extension cable (M1941A).

---

---

**Step 5.** While measuring SpO<sub>2</sub>, you should be aware of the following things:

---

**Warning**

---

**Inspect the application site every 2 to 3 hours to ensure skin quality and correct optical alignment. If the skin quality changes, move the transducer to another site.**

---

---

---

**Caution**

---

If you are printing via the infra-red printer port, make sure that the SpO<sub>2</sub> transducer is more than 50cm away, as the infra-red light may result in inaccurate measurements.

---

---

---

## Applying the Reusable Transducers

### The Adult Finger Transducer (M1191A)

Push the transducer over the fingertip so that

- The fingertip touches, but does not protrude from the end of the transducer,
- The transducer should be placed so that the cable is on the back of the hand.

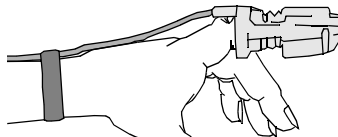

This ensures that the light sources cover the base of the fingernail, giving the best measurement results.

The cable can be held in place by the accompanying wristband. Keep the cable between the transducer and the wristband fairly loose, to protect the transducer and to maintain good measuring conditions.

**The Pediatric  
Finger  
Transducer  
(M1192A)**

Push the transducer over the fingertip so that the fingertip touches, but does not protrude from the end of the transducer.

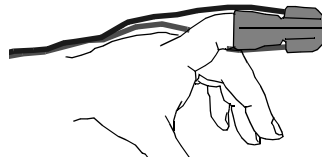

The cable can be held in place by tape if the patient is moving. Keep the cable between the transducer and the tape fairly loose, to protect the transducer and to maintain good measuring conditions.

**The Infant  
Finger  
Transducer  
(M1195A)**

The M1195A Infant Finger Transducer is suitable for fingers or toes with a diameter of from 7 to 8 mm (0.27 to 0.31"). Please select a finger or toe which is within this size range.

---



---

**Warning**

**If the sensor is applied to a finger or toe that is too small for the M1195A, the sensor may fall off the patient.**

**If the sensor is applied to a finger or toe that is too large for the M1195A, excessive pressure may be applied to the finger or toe which as a result can cause venous congestion distal from the application site, leading to interstitial edema, hypoxaemia and tissue malnutrition. Skin irritations or lacerations may occur as a result of the sensor being attached to one location for too long. To avoid skin irritations and lacerations, periodically inspect the sensor application site and change the application site at least every 4 hours.**

---



---

Push the transducer over the fingertip so that the fingertip touches, but does not protrude from the end of the transducer.

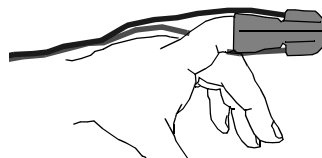

## Applying the Reusable Transducers

The cable can be held in place by tape if the patient is moving. Keep the cable between the transducer and the tape fairly loose, to protect the transducer and to maintain good measuring conditions.

### **The Neonatal Foot/Hand Transducer (M1193A)**

**Step 1.** Position the transducer on the foot or on the hand. Make sure that the optical components are opposite each other.

**Step 2.** Hold the transducer, and stretch the strap so that the transducer will be held firmly. Do not stretch the strap more than 2.5cm (1 inch).

---

---

### **Warning**

**Do not pull the strap too tightly, as this results in venous pulsation which may severely obstruct circulation and leads to inaccurate measurements.**

---

---

**Step 3.** Put the stretched strap into the slot on the top of the transducer, and hold it there.

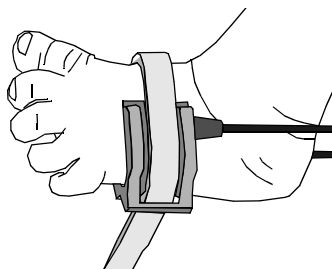

**Step 4.** Holding the stretched strap in the slot, thread the end through the latch.

**Step 5.** If the strap is too long, thread it through the second latch and secure it so that it is not in the way.

You can also attach the strap before slipping it onto the foot, this ensures that the strap is not too tight.

### **The Clip Transducer (M1194A)**

The clip transducer can be used as an alternative if the adult finger transducer does not produce satisfactory results. The preferred application site is the ear lobe, although other application sites with higher perfusion (such as the nostril) can be used.

You should be aware that the physiologically lower perfusion in the ear reduces the accuracy of the measurement. Do not use the ear transducer for patients with a small ear lobe as incorrect measurements may result.

Clip the transducer onto the fleshy part of the ear lobe as shown in the diagram below. The transducer should be located where perfusion is highest, normally

with the clip well over the edge of the earlobe so that the measuring parts are on the inner part of the earlobe.

The plastic fixing mechanism helps to minimize artifact created by patient motion. Do not position the probe on cartilage or where it presses against the head.

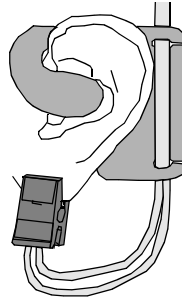

---

## Selecting the SpO<sub>2</sub> Setup

**Step 1.** Highlight the SpO<sub>2</sub> numeric and press on the TouchStrip.  
OR

**Step 1.** Press the **Setup** key.

**Step 2.** Move the highlight to “SpO<sub>2</sub>”.

**Step 3.** Press on the strip.

When you are finished with the SpO<sub>2</sub> Setup, press the **Main Screen** key.

---

## Switching the SpO<sub>2</sub> Measurement On

The SpO<sub>2</sub> measurement is switched on automatically when you plug in the SpO<sub>2</sub> transducer.

If the transducer is connected, you can switch the measurement on or off in SpO<sub>2</sub> setup (see “Selecting the SpO<sub>2</sub> Setup” on page 229):

**Step 1.** Select **SpO<sub>2</sub> On/Off**. This defines whether SpO<sub>2</sub> is to be measured or not.

**Step 2.** Select the appropriate setting:

On	SpO <sub>2</sub> will be measured. You can only switch the SpO <sub>2</sub> on if a sensor is connected.
Off	SpO <sub>2</sub> will not be measured.

---

## Setting Up the Tone Modulation

If tone modulation is switched on, the pitch of the QRS tone is related to the SpO<sub>2</sub> level. That is, if the SpO<sub>2</sub> level drops, the pitch of the QRS tone gets lower.

See also “Selecting the Source for the Heart Rate Numeric” on page 132 for information about the source of the QRS tone. If no other source is available, the QRS tone will be derived from the plethysmograph (the SpO<sub>2</sub> pulsatile wave).

### Switching the Tone Modulation On

In SpO<sub>2</sub> setup (see “Selecting the SpO<sub>2</sub> Setup” on page 229):

**Step 1.** Select **Tone Mod**. This defines whether the tone modulation is active or not.

**Step 2.** Select the appropriate setting:

On	The QRS tone will be modulated.
Off	The QRS tone will not be modulated.

### Changing the Volume of the QRS Tone

See also “Selecting the Volume of the Tone” on page 133.

In SpO<sub>2</sub> setup (see “Selecting the SpO<sub>2</sub> Setup” on page 229):



**Step 1.** Select **Volume**. This defines the volume of the tone that is to be heard each time a pulse is detected.

**Step 2.** Select the appropriate setting:  
from 0 = “off” to 10 = “very loud”

---

## Setting Up the SpO<sub>2</sub> Alarms

SpO<sub>2</sub> offers high and low limit alarms, and a high priority desaturation alarm. You cannot set the low alarm limit below the desaturation alarm limit.

---

### Warning

**If the INOP suppression for SpO<sub>2</sub> (during NBP measurements when measuring NBP on the same arm) is switched on, indication of a critical patient status such as sudden pulse loss or hypoxia may be delayed by up to 60 seconds.**

---

### Changing the alarm limits

In SpO<sub>2</sub> setup (see “Selecting the SpO<sub>2</sub> Setup” on page 229):

**Step 1.** Select **High Limit** if you want to set the upper alarm limit for the measurement.

Select **Low Limit** if you want to set the lower alarm limit for the measurement.

**Step 2.** Select the appropriate setting.

---

### Warning

**Select the upper alarm limit for SpO<sub>2</sub> in accordance with accepted clinical practices.**

**High oxygen levels may predispose a premature infant to retrolental fibroplasia, if this is a consideration do NOT set the high alarm limit to 100% (Changing the high SpO<sub>2</sub> alarm limit to 100% is equivalent to switching it off).**

---

### Adjusting the Desaturation Alarm Limit

The Desat alarm is a high priority (red) alarm notifying you of potentially life threatening drops in oxygen saturation.

**Step 1.** In the Setup SpO<sub>2</sub> menu, select **Desat Limit**.

**Step 2.** Select the appropriate setting.

### Enabling the alarms

In SpO<sub>2</sub> setup (see “Selecting the SpO<sub>2</sub> Setup” on page 229):

**Step 1.** Select **Alarms**. This defines whether the alarms derived from selected measurement is enabled.

**Step 2.** Select the appropriate setting.

On	The alarms are enabled.
Off	The alarms are disabled. The crossed bell symbol (X) will be displayed instead of the alarm limits.

### Testing the Alarm

You can test the SpO<sub>2</sub> alarm function manually:

**Step 1.** Connect an SpO<sub>2</sub> transducer and make sure the SpO<sub>2</sub> Measurement is switched on (“Switching the SpO<sub>2</sub> Measurement On” on page 229).

**Step 2.** Select a high limit below 100% (for example, 99%).

**Step 3.** Switch on test signals (see “Testing that the System Functions” on page 305).

The test signal will simulate an SpO<sub>2</sub> value of 100% and an **\*\*SpO<sub>2</sub> HIGH** alarm condition will be generated.

---

## Setting Up the Pleth Wave

See “Selecting a Wave for the Screen” on page 44 for information on how to get the pleth wave onto the screen.

The size of the pleth wave indicates the signal quality of the SpO<sub>2</sub> measurement. The size of the pleth wave is influenced by changes in perfusion at the transducer site, and by automatic scaling by the monitor.

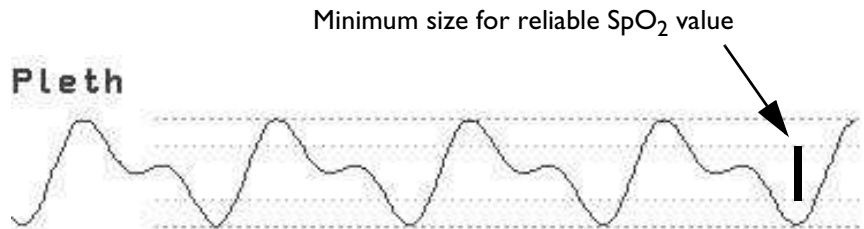

*Note*—The size of the pleth wave is NOT proportional to the pulse volume.

### Changing the Speed of the PLETH Wave

The speed of the pleth wave is the same as the speed for the ECG wave. See “Changing the Speed of the ECG Wave” on page 143.

### Setting PLETH as the source for the Pulse

See “Selecting the Source for the Heart Rate Numeric” on page 132, and “Changing the Heart Rate Alarm Limits” on page 134.

---

*Note*

In the case of very low pulse rates or strong arrhythmia, the pulse rate from Pleth may differ from the heart rate calculated from ECG.

---

## Troubleshooting the SpO<sub>2</sub>/PLETH Measurement

### If the Pulse Numeric Shows -?-

- If the pulse is being derived from an invasive pressure measurement, see “If the Pressure and Pulse Numerics Show -?-” on page 218.
- If the heart rate is being derived from an ECG measurement, see “If the HR Numeric Shows -?-” on page 144.

If the pulse is being derived from a PLETH measurement:

Check at the top left of the screen for an SpO<sub>2</sub> technical alarm message (an INOP).

### If the SpO<sub>2</sub> and Pulse Numerics Show -?-

Check at the top left of the screen for a technical alarm message (an INOP).

#### SpO<sub>2</sub> EQUIP MALF

Contact your biomedical department.

The SpO<sub>2</sub> hardware is faulty or the transducer cable is damaged.

#### SpO<sub>2</sub> ERRATIC

Make sure the SpO<sub>2</sub> transducer is correctly placed.

If this does not solve the problem, contact your biomedical department to make sure that the transducer is working.

#### SpO<sub>2</sub> INTERFERENCE

Cover the SpO<sub>2</sub> transducer so that it does not get as much light.

If this does not solve the problem, make sure that the transducer cable is not damaged, or close to power cords or other possible sources of electrical interference.

*Note*—This INOP arises when the level of ambient light is so high that the transducer cannot measure the pulse or if the transducer or its cable is picking up electrical interference.

<b>SpO<sub>2</sub> NO TRANSDUC</b>	<p>Make sure the SpO<sub>2</sub> transducer is connected.</p> <p>If you Silence this INOP, the measurement will be switched off.</p>
<b>SpO<sub>2</sub> NOISY SIGNAL</b>	<p>Try to reduce patient movement, or to relieve the cable strain on the transducer (for example, the wrist strap for the finger transducer)</p> <p><i>Note</i>—This INOP arises when excessive patient movement or electrical interference are causing irregular pulse patterns.</p>
<b>SpO<sub>2</sub> NON-PULSATILE</b>	<p>Try changing the application site of the transducer, or stimulating circulation at the current site.</p> <p><i>Note</i>—This INOP arises when the pulse is too weak or is not detectable (for example, where the transducer has slipped out of place, or the application site is too thin). It will also arise during an NBP measurement when NBP is being measured on the same arm as SpO<sub>2</sub>, unless the INOP suppression has been selected (see “Selecting INOP Suppression during NBP Measurements” on page 360).</p>
<b>SpO<sub>2</sub> TRANSDUC MALF</b>	<p>Contact your biomedical department.</p> <p>The SpO<sub>2</sub> transducer or transducer cable is faulty.</p>

## Troubleshooting the SpO<sub>2</sub>/PLETH Measurement

# Measuring Temperature (TEMP)

This chapter covers measuring temperature and how to set up your temperature measurement.

At the end of the chapter you will find information on how to deal with common measurement problems (troubleshooting).

- Preparing to Measure Temperature . . . . .238
- Selecting the TEMP Setup . . . . .239
- Switching the TEMP Measurement On . . . . .239
- Changing the TEMP Label . . . . .240
- Selecting the D TEMP Setup . . . . .240
- Switching the DTEMP Measurement On . . . . .241
- Selecting the Differential Temperature Source . . . . .241
- Setting Up the TEMP Alarms . . . . .242
- Troubleshooting the TEMP Measurement . . . . .243

---

## Preparing to Measure Temperature

---

### Caution

---

Use only temperature probes listed in “TEMP Accessories” on page 437.

---

**Step 1.** Select the correct type and size of probe. See “TEMP Accessories” on page 437 for a list of the probes that can be used with the Measurement Server.

If you are using a rectal probe (21075A/B, or 21076A/B), you should use it with a protective rubber cover, if possible.

**Step 2.** If you have selected a disposable probe, plug the temperature cable into the Measurement Server or Measurement Server Extension, and connect the probe to the cable.

If you have selected a reusable probe, plug the probe directly into the Measurement Server or Measurement Server Extension. Note: with each

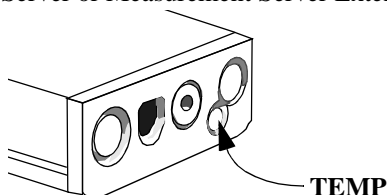

Measurement Server or Measurement Server Extension you can measure either invasive pressure or temperature. These measurements cannot be measured at the same time in one Server or Server Extension.

**Step 3.** Apply the probe to the appropriate part of the patient’s body.



---

## Selecting the TEMP Setup

**Step 1.** Highlight the TEMP numeric and press on the TouchStrip.  
OR

**Step 1.** Press the **Setup** key.

**Step 2.** Move the highlight to “TEMP”.

**Step 3.** Press on the strip.

When you are finished with the TEMP Setup, press the **Main Screen** key.

---

## Switching the TEMP Measurement On

The temperature measurement is switched on automatically when you plug in the temperature transducer.

If the transducer is connected, you can switch the measurement on or off in TEMP setup (see “Selecting the TEMP Setup” on page 239):

**Step 1.** Select **TEMP On/Off**. This defines whether the temperature is to be measured or not.

**Step 2.** Select the appropriate setting:

On	Temperature will be measured. You can only switch the temperature on if a probe is connected.
Off	Temperature will not be measured.

If you get a prompt message saying **TEMP equip malf - cannot switch on**, you should contact your biomedical department. The temperature hardware is faulty.

## Changing the TEMP Label

If more than one Temperature is measured, labels that are assigned to one temperature channel cannot be selected for the other temperature channel to avoid duplicate labels.

From the TEMP Setup menu (see “Selecting the TEMP Setup” on page 239)

**Step 1.** Select **Label1**.

**Step 2.** Select the appropriate setting:

T1	non-specific temperature label.
Tart	arterial temperature
Tcore	core temperature
Tesop	esophageal temperature
Tnaso	nasopharyngeal temperature
Trect	rectal temperature
Tskin	skin temperature
Tven	venous temperature

*Note*—The label automatically uses the color, alarm limits and other settings for that label.

---

## Selecting the $\Delta$ TEMP Setup

**Step 1.** Highlight the  $\Delta$  TEMP numeric and press on the TouchStrip.  
OR

**Step 1.** Press the **Setup** key.

**Step 2.** Move the highlight to “ $\Delta$  TEMP”.

**Step 3.** Press on the strip.

When you are finished with the  $\Delta$  TEMP Setup, press the **Main Screen** key.

---

## Switching the $\Delta$ TEMP Measurement On

The  $\Delta$  TEMP calculation is switched on automatically when you plug in two temperature probes.

If the probes are connected, you can switch the calculation on or off in  $\Delta$ TEMP setup (see “Selecting the D TEMP Setup” on page 240):

**Step 1.** Select  $\Delta$  TEMP On/Off. This defines whether the temperature difference is to be calculated or not.

**Step 2.** Select the appropriate setting:

On	Temperature difference will be calculated. You can only switch the $\Delta$ TEMP on if two probes are connected.
Off	Temperature will not be measured.

---

## Selecting the Differential Temperature Source

In  $\Delta$  TEMP setup (see “Selecting the D TEMP Setup” on page 240):

**Step 1.** Select  $\Delta$  T Source.

**Step 2.** select the appropriate setting:

T2 – T1	The value for T1 will be subtracted from the value for T2 to give the $\Delta$ TEMP.
T1 - T2	The value for T2 will be subtracted from the value for T1 to give the $\Delta$ TEMP.

## Setting Up the TEMP Alarms

### Changing the alarm limits.

In TEMP setup (see “Selecting the TEMP Setup” on page 239):

**Step 1.** Select `High Limit` if you want to set the upper alarm limit for the measurement. Note that changing the label could change the alarm limits.

**Step 2.** Select `Low Limit` if you want to set the lower alarm limit for the measurement.

**Step 3.** Select the appropriate setting.

### Enabling the alarms.

In TEMP setup (see “Selecting the TEMP Setup” on page 239):

**Step 4.** Select **Alarms**. This defines whether the alarms are enabled.

**Step 5.** Select the appropriate setting.

On	The alarms are enabled
Off	The alarms are disabled. The crossed bell symbol ( <del>🔔</del> ) will be displayed instead of the alarm limits.

---

Note

There are no alarms for the  $\Delta$  TEMP measurement.

---

---

## Troubleshooting the TEMP Measurement

### If the TEMP Numeric Shows -?-

Check at the top left of the screen for a technical alarm message (an INOP).

**TEMP<sup>1</sup> EQUIP MALF** Contact your biomedical department.  
The temperature hardware is faulty.

**TEMP<sup>1</sup> NO TRANSDUCER** Make sure the TEMP probe is connected to the Measurement Server.

If you Silence this INOP, the measurement will be switched off.

**TEMP<sup>1</sup> OVERRANGE** Make sure that the application site of the transducer is not in contact with something hot or cold.

*Note*—This INOP arises when the temperature is less than  $-1^{\circ}\text{C}$  ( $30^{\circ}\text{F}$ ), or greater than  $45^{\circ}\text{C}$  ( $113^{\circ}\text{F}$ ).

<sup>1</sup>TEMP is replaced by the selected temperature label.

## Troubleshooting the TEMP Measurement

# Measuring Carbon Dioxide Using the Mainstream Method (M3016A)

There are two measurement methods for CO<sub>2</sub>:

- the Mainstream measurement using the M3016A Extension (Option #A01) to the Multi-Measurement Server.
- the Microstream (sidestream) measurement using the M3015A Extension to the Multi-Measurement Server.

This chapter covers measuring CO<sub>2</sub> using the Mainstream method and how to set up your CO<sub>2</sub> measurement. (For information on the Microstream CO<sub>2</sub> measurement refer to “Measuring Carbon Dioxide Using the Microstream Method (M3015A)” on page 257.)

At the end of the chapter you will find information on how to deal with common measurement problems (troubleshooting)

- Preparing to Measure CO<sub>2</sub> .....247
- Selecting the CO<sub>2</sub> Setup .....249
- Switching the CO<sub>2</sub> Measurement On .....249
- Setting Up the CO<sub>2</sub> and AwRR Alarms .....252
- Changing the AwRR alarm limits. ....252
- Troubleshooting the CO<sub>2</sub> Measurement .....254

---

Note

FDA clearance does not authorize the use of the device in airplanes including helicopters.

---

## The CO<sub>2</sub> Measurement

The M3016A Option #A01 Measurement Server Extension, together with the M1460A transducer and M1465A/14363A Airway adapter, measures the partial pressure of carbon dioxide in the patient's airway. It is intended for use with ventilated adult, pediatric and neonatal patients. From the partial pressure measurement the end tidal carbon dioxide (EtCO<sub>2</sub>) is derived. EtCO<sub>2</sub> is the peak CO<sub>2</sub> value measured during one expiration. The EtCO<sub>2</sub> measurement uses a technique based on the absorption of infrared radiation by some gases. It indicates the change in:

- The elimination of CO<sub>2</sub>
- The delivery of O<sub>2</sub> to the lungs

and can be used to control the ventilation of the patient.

---

---

### Warning

**The EtCO<sub>2</sub> readings do not always correlate closely with paCO<sub>2</sub> values, especially in neonatal patients and patients with pulmonary disease, pulmonary embolism or inappropriate ventilation.**

---

---

The CO<sub>2</sub> measurement extension provides the system with an EtCO<sub>2</sub> value, a CO<sub>2</sub> waveform, and the following additional values

- Inspired Minimum CO<sub>2</sub> (ImCO<sub>2</sub>) - the smallest value sensed during inspiration (displayed as a numeric).
- Airway Respiration Rate (AwRR) - the number of breaths per minute (displayed as a numeric).
- The uncorrected instantaneous CO<sub>2</sub> value - displayed in Calibration Mode.



---

---

## Preparing to Measure CO<sub>2</sub>

---

---

**Warning** CO<sub>2</sub> should not be measured in the presence of aerosolized pharmaceuticals.

**Before CO<sub>2</sub> measurement is used for the first time, the altitude must be set to the correct value. An incorrect altitude setting will result in incorrect CO<sub>2</sub> readings.**

---

---

**Step 1.** Attach the transducer connector to the CO<sub>2</sub> connector on the measurement extension and wait 20 minutes to ensure that the transducer has reached operating temperature and is in a stable thermal condition.

*Note*—If this transducer has not been calibrated at this monitor before, then switch on Calibration Mode in the CO<sub>2</sub> Setup and calibrate the transducer as described in Step 2.e. onwards below. An accuracy check is recommended at least once a week or whenever the CO<sub>2</sub> readings are in doubt.

**Step 2.** Perform an accuracy check using the calstick and, if necessary, calibrate the transducer:

- Switch on Calibration Mode in the CO<sub>2</sub> Setup (see “Selecting the CO<sub>2</sub> Setup” on page 249).
- Check that the calibration value displayed next to **Start Cal 1:** in CO<sub>2</sub> Setup is the same as that indicated on the calstick. (If not, calibrate the transducer as described in step e. onwards below.)
- Place the transducer on the low cell of the calstick (labelled 0.0 mmHg or “ZERO”). The reading on the screen should be zero within  $\pm 1$  mmHg within 1 minute.
- Place the transducer on the high cell of the calstick. The reading on the screen should be within  $\pm 1$  mmHg of the value on the calstick within 1 minute.

If both readings are in range, you can leave Calibration Mode, attach the transducer to the patient’s breathing circuit and begin monitoring (see Step 3). If either of the readings is out of range, the transducer must be calibrated:

## Preparing to Measure CO<sub>2</sub>

- e. Check that the windows on the calstick are clean and clear.
- f. Place the transducer on one of the calstick cells and select **Start Cal 1**.
- g. Enter the calibration value printed on the calstick then press the Confirm softkey. The calibration starts.
- h. When the message **CO<sub>2</sub> CAL 1 calibration done - start CAL 2 calibration** appears (and the INOP message **CO<sub>2</sub> WAIT CAL 2**), put the transducer on the other cell and select **Start Cal 2** then press the Confirm softkey.
- i. When the **CO<sub>2</sub> calibration completed - leave CAL Mode** message appears, calibration is complete and you can switch off Calibration mode.

**Step 3.** Referring to the diagram below, attach the transducer to the patient's breathing circuit.

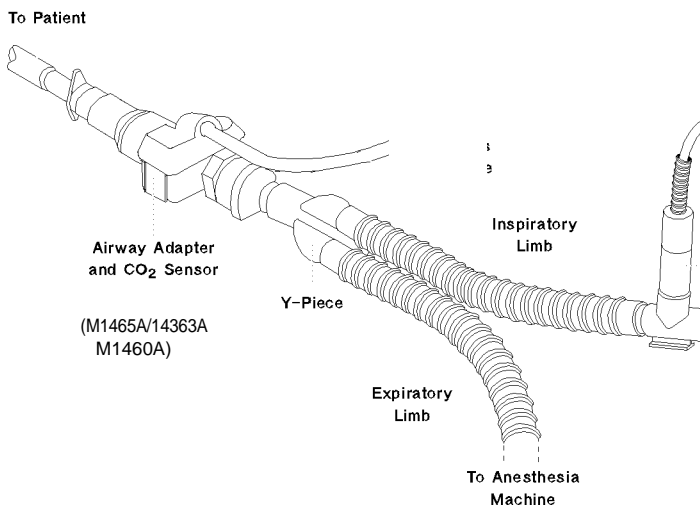

---

---

### Warning

**Support the transducer and Airway adapter to prevent stress on the endotracheal tube.**

**Use only sterilized airway adapters to avoid infection.**

---

---

- Open the latch and place the transducer onto the Airway adapter. Place the airway adapter in the patient's breathing circuit between the endotracheal tube and the Y-piece.
- The **CO<sub>2</sub> SENSOR WARM UP** message may again be displayed until the transducer reaches operating temperature.

To remove the transducer from the airway adapter, open the latch and pull out the airway adapter.

---

## Selecting the CO<sub>2</sub> Setup

**Step 1.** Highlight the CO<sub>2</sub> numeric or wave and press on the TouchStrip.  
OR

**Step 1.** Press the **Setup** key.

**Step 2.** Move the highlight to **CO<sub>2</sub>**.

**Step 3.** Press on the strip.

When you are finished with the CO<sub>2</sub> Setup, press the **Main Screen** key.

---

## Switching the CO<sub>2</sub> Measurement On

The CO<sub>2</sub> measurement is switched on automatically when you plug in the CO<sub>2</sub> transducer.

If the transducer is connected, you can switch the measurement on or off in CO<sub>2</sub> setup (see “Selecting the CO<sub>2</sub> Setup” on page 249):

**Step 1.** Select **CO<sub>2</sub> On/Off**. This defines whether CO<sub>2</sub> is to be measured or not.

**Step 2.** Select the appropriate setting:

On	CO <sub>2</sub> will be measured. You can only switch the CO <sub>2</sub> on if a sensor is connected.
Off	CO <sub>2</sub> will not be measured.

---

## Selecting the Respiration Rate Source and Switching AwRR On/Off

If Respiration and CO<sub>2</sub> are measured, two respiration rates are available. One of the respiration rates must be selected for monitoring and alarming; the other respiration source is then switched off. To select the respiration rate source:

**Step 1.** Select CO<sub>2</sub> setup (see “Selecting the CO<sub>2</sub> Setup” on page 249).

**Step 2.** Select **Resp Alarms**

**Step 3.** Select **Resp Source**

**Step 4.** Select the appropriate setting:

AwRR	The respiration rate from the CO <sub>2</sub> measurement is used for monitoring and alarming. The Respiration measurement is switched off.
Resp	The respiration rate from the Respiration measurement is used for monitoring and alarming. The AwRR channel from the CO <sub>2</sub> measurement is switched off.
Auto	The monitor automatically selects a source; AwRR if available, RR if AwRR not available.
Off	Both respiration sources are switched off.

---

## Setting up the Corrections

The CO<sub>2</sub> absorption is influenced by the temperature and the water vapor in the patient's breath. See the Chapter "Configuration" for how to set the humidity correction.

The CO<sub>2</sub> absorption is also influenced by barometric pressure and by the proportions of O<sub>2</sub> and N<sub>2</sub>O in the mixture.

An adjustment for barometric pressure is made during installation of the monitor when the altitude of operation is entered.

For O<sub>2</sub> a standard correction of 45% is made.

To make a correction for N<sub>2</sub>O:

**Step 1.** In CO<sub>2</sub> setup (see "Selecting the CO<sub>2</sub> Setup" on page 249), select **N<sub>2</sub>O Corr.**

**Step 2.** Set N<sub>2</sub>O correction to **On** if the ventilation gas mixture contains N<sub>2</sub>O and to **Off** if the gas mixture contains no N<sub>2</sub>O.

## Setting Up the CO<sub>2</sub> and AwRR Alarms

For the CO<sub>2</sub> measurement, alarms are given for high EtCO<sub>2</sub>, low EtCO<sub>2</sub> and high ImCO<sub>2</sub>.

For the Airway Respiration Rate, alarms are given for high AwRR, low AwRR and apnea. For these alarms to be given, AwRR must be selected as respiration rate source. (See “Selecting the Respiration Rate Source and Switching AwRR On/Off” on page 250.)

### Changing the CO<sub>2</sub> alarm limits

In CO<sub>2</sub> setup (see “Selecting the CO<sub>2</sub> Setup” on page 249):

- Step 1.** Select **EtCO<sub>2</sub> High** or **ImCO<sub>2</sub> High** if you want to set one of the upper alarm limits for the measurement.  
Select **EtCO<sub>2</sub> Low** if you want to set the lower alarm limit for the measurement.
- Step 2.** Select the appropriate setting.

### Enabling the CO<sub>2</sub> alarms

In CO<sub>2</sub> setup (see “Selecting the CO<sub>2</sub> Setup” on page 249):

- Step 3.** Select **CO<sub>2</sub> Alarms**. This defines whether the alarms derived from CO<sub>2</sub> are enabled.
- Step 4.** Select the appropriate setting.

On	The alarms are enabled
Off	The alarms are disabled. The crossed bell symbol (X) will be displayed instead of the alarm limits.

### Changing the AwRR alarm limits

In CO<sub>2</sub> setup (see “Selecting the CO<sub>2</sub> Setup” on page 249) select **AwRR Alarms**:

- Step 1.** Select **High Limit** if you want to set the upper alarm limit for the measurement.  
Select **Low Limit** if you want to set the lower alarm limit for the measurement.
- Step 2.** Select the appropriate setting.

**Changing the Apnea Alarm Delay**

In CO<sub>2</sub> setup (see “Selecting the CO<sub>2</sub> Setup” on page 249) select **AwRR Alarms**:

- Step 1.** Select **Apnea Time** to set the time limit before the alarm is indicated if the patient stops breathing.
- Step 2.** Select the appropriate setting.

**Warning**

**The safety and effectiveness of the respiration measurement method in the detection of apnea, particularly the apnea of prematurity and apnea of infancy, has not been established.**

**Enabling or Disabling AwRR and Apnea Alarms**

In CO<sub>2</sub> setup (see “Selecting the CO<sub>2</sub> Setup” on page 249) select **AwRR Alarms**:

- Step 1.** Select **Alarms**. This defines whether the alarms derived from the airway respiration signal are enabled.
- Step 2.** Select the appropriate setting.

On	The alarms are enabled
Off	The alarms are disabled. The crossed bell symbol (X) will be displayed instead of the alarm limits.

## Troubleshooting the CO<sub>2</sub> Measurement

### If the CO<sub>2</sub> Numerics Show -?-

Check at the top left of the screen for a technical alarm message (an INOP).

#### CO<sub>2</sub> EQUIP MALF

Contact your biomedical department.

The CO<sub>2</sub> hardware or the transducer is faulty.

#### CO<sub>2</sub> NO TRANSDUCER

There is no CO<sub>2</sub> transducer connected. If you replace the transducer, the new transducer must be calibrated (see “Preparing to Measure CO<sub>2</sub>” on page 247).

If you Silence this INOP, the measurement will be switched off.

#### CO<sub>2</sub> FAILED CAL

Check that the transducer is on the correct Cal cell and that the power has not failed. Repeat the calibration. If the INOP reappears, try another transducer. If the problem persists, contact your biomedical engineer or Philips Service representative.

#### CO<sub>2</sub> CHECK CAL

CO<sub>2</sub> value is outside the expected range (< -4 mmHg or >150 mmHg). Check accuracy and recalibrate the transducer, if necessary.

#### CO<sub>2</sub> WAIT CAL2

Calibration on the first calstick cell is complete. The Monitor is waiting for calibration on the second calstick cell to be started.

#### CO<sub>2</sub> CAL RUNNING

The CO<sub>2</sub> calibration is running.

#### CO<sub>2</sub> CAL MODE

Cal. mode is switched on but no calibration has been started.



**If the CO<sub>2</sub> Numeric is Displayed with a ?**

**CO<sub>2</sub> SENSOR WARM UP**      The sensor has not yet reached operating temperature.

**If the CO<sub>2</sub> Wave is Clipped**

**CO<sub>2</sub> CHANGE SCALE**      The EtCO<sub>2</sub> value is greater than the scale currently selected. Select a larger scale to see the whole wave.

**If the CO<sub>2</sub> Readings are Low**

- Perform an accuracy check (see “Preparing to Measure CO<sub>2</sub>” on page 247) and recalibrate the transducer if required.
- Check the humidity correction setting which is displayed in the CO<sub>2</sub> setup. In BTPS mode (body temperature pressure saturated) the readings correspond to the CO<sub>2</sub> partial pressure in humidified gases. These readings are about 6 to 12% lower than the readings in STPD (standard temperature pressure dry) mode. For changing the humidity correction mode see “Extra Configuration for the CO<sub>2</sub> Measurement” on page 365.
- Check the altitude setting. If the actual altitude is higher than the set altitude, the CO<sub>2</sub> readings are typically 5% lower than normal for every 1000m difference.

**If the CO<sub>2</sub> Readings are High**

- Perform an accuracy check (see “Preparing to Measure CO<sub>2</sub>” on page 247) and recalibrate the transducer if required.
- Check the humidity correction setting which is displayed in the CO<sub>2</sub> setup. In STPD (standard temperature pressure dry) mode, the readings correspond to the CO<sub>2</sub> partial pressure in dry gases. These readings are about 6 to 12% higher than the readings in BTPS mode (body temperature pressure saturated). For changing the humidity correction mode see “Extra Configuration for the CO<sub>2</sub> Measurement” on page 365.
- Check the altitude setting. If the actual altitude is lower than the set altitude, the CO<sub>2</sub> readings are typically 5% higher than normal for every 1000m difference.

## Troubleshooting the CO<sub>2</sub> Measurement

# Measuring Carbon Dioxide Using the Microstream Method (M3015A)

There are two measurement methods for CO<sub>2</sub>:

- the Mainstream measurement using the M3016A Extension (Option #A01) to the Multi-Measurement Server.
- the Microstream<sup>1</sup> (sidestream) measurement using the M3015A Extension to the Multi-Measurement Server.

This chapter covers measuring CO<sub>2</sub> using the Microstream method and how to set up your CO<sub>2</sub> measurement. (For information on using the Mainstream method refer to the chapter “Measuring Carbon Dioxide Using the Mainstream Method (M3016A)”).

At the end of this chapter you will find information on how to deal with common measurement problems (troubleshooting).

- Preparing to Measure CO<sub>2</sub> .....259
- Selecting the Accessories .....259
- Selecting the CO<sub>2</sub> Setup .....262
- Switching the CO<sub>2</sub> Measurement On .....262
- Setting Up the CO<sub>2</sub> and AwRR Alarms .....264
- Changing the AwRR alarm limits. ....265
- Troubleshooting the CO<sub>2</sub> Measurement .....266

---

1. The following are trademarks of Oridion Medical Inc.: “Microstream”, “FilterLine”, “CapnoLine”, “Smart CapnoLine”, and “NIV Line”.

## The CO<sub>2</sub> Measurement

The M3015A Measurement Server Extension measures the partial pressure of carbon dioxide in a patient's expired gas using Microstream technology.

In intubated patients, a sample of the respiratory gas is drawn from the patient's breathing circuit through an airway adapter and a gas sampling tube. In non-intubated patients, the gas sample is drawn through a nasal or oral-nasal cannula.

When using the appropriate accessories, the Microstream CO<sub>2</sub> measurement can be used with adult, pediatric, and neonatal patients.

From the partial pressure measurement, the end tidal carbon dioxide (EtCO<sub>2</sub>) is derived. EtCO<sub>2</sub> is the peak CO<sub>2</sub> value measured during one expiration. The EtCO<sub>2</sub> measurement uses a technique based on the absorption of infrared radiation by some gases. It indicates the change in:

- The elimination of CO<sub>2</sub>
- The delivery of O<sub>2</sub> to the lungs

and can be used to control the ventilation of a patient.

---

---

### Warning

**The EtCO<sub>2</sub> readings do not always correlate closely with paCO<sub>2</sub> values, especially in neonatal patients and patients with pulmonary disease, pulmonary embolism or inappropriate ventilation.**

---

---

The CO<sub>2</sub> measurement extension provides the system with an EtCO<sub>2</sub> value, a CO<sub>2</sub> waveform, and the following additional values

- Inspired Minimum CO<sub>2</sub> (ImCO<sub>2</sub>) - the smallest value sensed during inspiration (displayed as a numeric).
- Airway Respiration Rate (AwRR) - the number of breaths per minute (displayed as a numeric).

---

## Preparing to Measure CO<sub>2</sub>

### Selecting the Accessories

---

Note                      The M3015A can be operated with the special Microstream accessories only.

---

A variety of Microstream accessories is available for all application areas.

Various sizes of Microstream accessories for adult, pediatric and neonatal patients are available.

For intubated patients, a “FilterLine Set”, (which is a ready-made combination of an airway adapter and a Microstream “FilterLine” sample tube) is available for use with non-humidified ventilation, while the “FilterLine H” or a “FilterLine H Set” should be used for humidified ventilation.

In non-intubated patients, the gas sample is taken through a “CapnoLine H” or a “Smart CapnoLine” (which is a combined oral-nasal CapnoLine H). In parallel to the measurement of CO<sub>2</sub>, Oxygen (O<sub>2</sub>) may be delivered to the patient to support gas exchange. This is done by using an “CapnoLine H O<sub>2</sub>” or a “Smart CapnoLine O<sub>2</sub>” (a combined oral-nasal-O<sub>2</sub>-CO<sub>2</sub> CapnoLine H).

An NIV sample line is used for mask-ventilated patients.

For M3015A Microstream CO<sub>2</sub> Extension accessories, see “Microstream CO<sub>2</sub> Accessories (Sidestream)” on page 436.

---

---

### Warning

**Use only Microstream accessories (as listed in the Accessories section) to ensure correct functioning of the Microstream CO<sub>2</sub> measurement.**

**Do not re-use, clean or sterilize Microstream CO<sub>2</sub> accessories as they are intended for single-patient, one-time use.**

---

---

## **Setting up Microstream CO<sub>2</sub>**

For instructions on how to apply Microstream accessories, please refer to the user instructions that are supplied with the accessories.

---

---

### **Warning**

- **Danger - explosion hazard - sidestream measurement should not be used in the presence of flammable anesthetics such as:**
    - Flammable anesthetic mixture with air
    - Flammable anesthetic mixture with Oxygen or Nitrous Oxide
  - **CO<sub>2</sub> should not be measured in the presence of aerosolized pharmaceuticals.**
  - **When using a nasal sample line, if one or both nostrils are partially or completely blocked, or the patient is breathing through the mouth, the displayed EtCO<sub>2</sub> values may be significantly too low.**
  - **When using the Sidestream CO<sub>2</sub> measurement on patients who are receiving or have recently received anesthetics, the outlet must be connected to a scavenging system or to the anesthesia machine/ventilator to prevent exposure of medical staff to anesthetics.**
- 
-

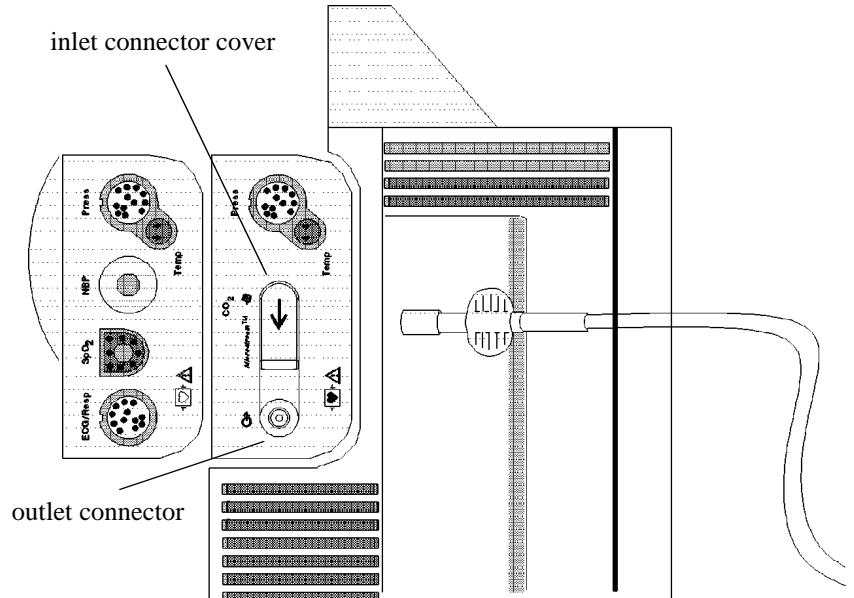

## Removing Exhaust Gases from the System

The sample gas can be removed to a scavenging system using the Exhaust Tube (M1015-40001). The exhaust tube is attached to the Measurement Extension at the Outlet connector (see diagram above).

## Selecting the CO<sub>2</sub> Setup

**Step 1.** Highlight the CO<sub>2</sub> numeric or wave and press on the TouchStrip.  
OR

**Step 1.** Press the **Setup** key.

**Step 2.** Move the highlight to “CO<sub>2</sub>”.

**Step 3.** Press on the strip.

When you are finished with the CO<sub>2</sub> Setup, press the **Main Screen** key.

---

## Switching the CO<sub>2</sub> Measurement On

The CO<sub>2</sub> measurement is switched on automatically when you connect the CapnoLine or FilterLine to the measurement extension.

If the FilterLine is connected, you can switch the measurement on or off in CO<sub>2</sub> setup (see “Selecting the CO<sub>2</sub> Setup” on page 262):

**Step 1.** Select CO<sub>2</sub> **On/Off**. This defines whether CO<sub>2</sub> is to be measured or not.

**Step 2.** Select the appropriate setting:

On	CO <sub>2</sub> will be measured. You can only switch the CO <sub>2</sub> on if a FilterLine is connected.
Off	CO <sub>2</sub> will not be measured.



## Selecting the Respiration Rate Source and Switching AwRR On/Off

If Respiration and CO<sub>2</sub> are measured, two respiration rates are available. One of the respiration rates must be selected for monitoring and alarming; the other respiration source is then switched off. To select the respiration rate source:

**Step 1.** Select CO<sub>2</sub> setup (see “Selecting the CO<sub>2</sub> Setup” on page 262).

**Step 2.** Select **Resp Alarms**

**Step 3.** Select **Resp Source**

**Step 4.** Select the appropriate setting:

AwRR	The respiration rate from the CO <sub>2</sub> measurement is used for monitoring and alarming. The Respiration measurement is switched off.
RESP	The respiration rate from the Respiration measurement is used for monitoring and alarming. The AwRR channel from the CO <sub>2</sub> measurement is switched off.
Auto	The monitor automatically selects a source; AwRR if available, RR if AwRR not available.
Off	Both respiration sources are switched off.

## Setting up the N<sub>2</sub>O Correction

The CO<sub>2</sub> absorption is influenced by the proportion of N<sub>2</sub>O in the gas mixture.

To make a correction for N<sub>2</sub>O:

**Step 1.** In CO<sub>2</sub> setup (see “Selecting the CO<sub>2</sub> Setup” on page 262), select **N<sub>2</sub>O Corr.**

**Step 2.** Set N<sub>2</sub>O correction to **On** if the gas mixture contains N<sub>2</sub>O and to **Off** if the gas mixture contains no N<sub>2</sub>O.

---

Note

Newer CO<sub>2</sub> hardware does not require the N<sub>2</sub>O correction. If the N<sub>2</sub>O correction is not available in the CO<sub>2</sub> Setup, this indicates that the CO<sub>2</sub> measurement in your Measurement Server Extension does not require N<sub>2</sub>O correction.

---

---

## Setting Up the CO<sub>2</sub> and AwRR Alarms

For the CO<sub>2</sub> measurement, alarms are given for high EtCO<sub>2</sub>, low EtCO<sub>2</sub> and high ImCO<sub>2</sub>.

For the Airway Respiration Rate, alarms are given for high AwRR, low AwRR and apnea. For these alarms to be given, AwRR must be selected as respiration rate source. (See “Selecting the Respiration Rate Source and Switching AwRR On/Off” on page 263.)

### Changing the CO<sub>2</sub> alarm limits

In CO<sub>2</sub> setup (see “Selecting the CO<sub>2</sub> Setup” on page 262):

**Step 1.** Select **EtCO<sub>2</sub> High** or **ImCO<sub>2</sub> High** if you want to set one of the upper alarm limits for the measurement.

Select **EtCO<sub>2</sub> Low** if you want to set the lower alarm limit for the measurement.

**Step 2.** Select the appropriate setting.

## Enabling the CO<sub>2</sub> alarms

In CO<sub>2</sub> setup (see “Selecting the CO<sub>2</sub> Setup” on page 262):

**Step 1.** Select **CO<sub>2</sub> Alarms**. This defines whether the alarms derived from CO<sub>2</sub> are enabled.

**Step 2.** Select the appropriate setting.

On	The alarms are enabled
Off	The alarms are disabled. The crossed bell symbol (X) will be displayed instead of the alarm limits.

## Changing the AwRR alarm limits

In CO<sub>2</sub> setup (see “Selecting the CO<sub>2</sub> Setup” on page 262) select **AwRR Alarms**:

**Step 1.** Select **High Limit** if you want to set the upper alarm limit for the measurement.

Select **Low Limit** if you want to set the lower alarm limit for the measurement.

**Step 2.** Select the appropriate setting.

## Changing the Apnea Alarm Delay

In CO<sub>2</sub> setup (see “Selecting the CO<sub>2</sub> Setup” on page 262) select **AwRR Alarms**:

**Step 1.** Select **Apnea Time** to set the time limit before the alarm is indicated, if the patient stops breathing.

**Step 2.** Select the appropriate setting.

---



---

### Warning

**The safety and effectiveness of the respiration measurement method in the detection of apnea, particularly the apnea of prematurity and apnea of infancy, has not been established.**

**The selected apnea alarm delay may be prolonged by up to 17 seconds, if an apnea occurs during the automatic zero process.**

---



---

### Enabling or Disabling AwRR and Apnea Alarms

In CO<sub>2</sub> setup (see “Selecting the CO<sub>2</sub> Setup” on page 262) select **AwRR Alarms**:

- Step 1.** Select **Alarms**. This defines whether the alarms derived from the airway respiration signal are enabled.
- Step 2.** Select the appropriate setting.

On	The alarms are enabled
Off	The alarms are disabled. The crossed bell symbol (X) will be displayed instead of the alarm limits.

---

## Troubleshooting the CO<sub>2</sub> Measurement

### If no CO<sub>2</sub> Numeric and Wave are Displayed

The hardware of the Measurement server Extension might be incompatible with your monitor. Contact your biomedical department.

### If the CO<sub>2</sub> Numerics Show -?-

Check at the top left of the screen for a technical alarm message (an INOP).

**CO<sub>2</sub> EQUIP MALF**

Contact your biomedical department.

Either

1) the CO<sub>2</sub> hardware or firmware in the M3015A Measurement server extension is incompatible with the M3001A Measurement Server or M3046A monitor,

Or

2) the CO<sub>2</sub> hardware is faulty.

<b>CO<sub>2</sub> UPDATE FW</b>	<p>The software in the Measurement Extension does not match the software in the Measurement Server. This is only likely to occur after a repair or upgrade.</p> <p>Contact your biomedical department</p>
<b>CO<sub>2</sub> NO TUBING</b>	<p>The FilterLine is disconnected, or an incorrect line is attached.</p> <p>If you Silence this INOP, the measurement will be switched off.</p>
<b>CO<sub>2</sub> SENSOR WARM UP</b>	<p>The measurement has not yet reached operating temperature.</p>
<b>CO<sub>2</sub> OCCLUSION</b>	<p>The FilterLine or exhaust tube is blocked to the extent that a measurement sample cannot be taken.</p> <p>Check the FilterLine and exhaust tube, then disconnect and reconnect the FilterLine. If the INOP is still displayed, use a new FilterLine.</p>
<b>CO<sub>2</sub> OVERRANGE</b>	<p>The CO<sub>2</sub> value is higher than the measurement range.</p>
<b>CO<sub>2</sub> PURGING</b>	<p>The Measurement Extension is purging the FilterLine. This occurs when an occlusion is detected in the line or airway adapter. If the occlusion is not removed by purging, the Measurement Extension will go into Standby Mode and a “CO<sub>2</sub> OCCLUSION” INOP will be displayed.</p>

**If the CO<sub>2</sub> numerics are displayed with a ?**

**CO<sub>2</sub> AUTO ZERO**

The automatic zero process is running. This takes typically 10 seconds up to a maximum of 30 seconds. During this time the CO<sub>2</sub> values may not be accurate. If the auto zero takes longer than 15 seconds, an INOP is triggered and the numerics will show -?-.

**If the CO<sub>2</sub> Wave is Clipped**

**CO<sub>2</sub> CHANGE SCALE**

The EtCO<sub>2</sub> value is greater than the scale currently selected. Select a larger scale to see the whole wave.

**If the CO<sub>2</sub> Values are Low**

- If the patient is not intubated and a nasal FilterLine is used, the CO<sub>2</sub> values will always tend to be lower than with intubated patients. If values appear extremely low, check whether the patient is breathing through the mouth or whether one nostril is blocked.
- For intubated patients:
  1. Check that the FilterLine is connected firmly to the airway adapter and the CO<sub>2</sub> input on the M3015A. Loose connections can cause leakage resulting in low readings.
  2. Check the humidity correction setting which is displayed in the CO<sub>2</sub> setup. In BTPS (body temperature pressure saturated) mode the readings correspond to the CO<sub>2</sub> partial pressure in humidified gases. These readings are about 6% lower than the readings in STPD (standard temperature pressure dry) mode. To change the humidity correction setting see “Extra Configuration for the CO<sub>2</sub> Measurement” on page 365.
  3. If above checks do not change the situation, try a new FilterLine.

If values are still low, contact your biomedical department or Philips representative to have the accuracy of the instrument checked.

**If the CO<sub>2</sub>  
values are  
High**

- Check the humidity correction setting which is displayed in the CO<sub>2</sub> setup. In STPD (standard temperature pressure dry) mode, the readings correspond to the CO<sub>2</sub> partial pressure in dry gases. These readings are about 6% higher than the readings in BTPS mode (body temperature pressure saturated). For changing the humidity correction mode see “Extra Configuration for the CO<sub>2</sub> Measurement” on page 365.

If values are still high, contact your biomedical department or Philips representative to have the accuracy of the instrument checked.

## Troubleshooting the CO<sub>2</sub> Measurement



# Examining Trends and Events

This chapter covers what you need to know so you can look at and print measurement data collected over a period of time.

- Viewing the Trend .....272
- Printing and Recording the Trend Data .....273
- Storing Events.....274
- Reviewing Events .....275
- Stopping Printouts .....278

---

## Viewing the Trend

**Step 1.** Press on the strip below the **Trends** SmartKey (you may have to press ◀ or ▶ to find this SmartKey, if it is configured).



OR

**Step 1.** Press the **Setup** key.

**Step 2.** Move the highlight to **Trends**.

**Step 3.** Press on the strip.

### Selecting a Short or Long Term Trend

A short term trend has data at one minute intervals (for a maximum of ten hours). To look at the more recent data in greater detail, press the **Short Trends** softkey.

A long term trend has data at five minute intervals (for a maximum of 48 hours). If you want to look at a long term trend, press the **Long Trends** softkey.

### Viewing the Earlier or Later Data

To view earlier data than shown in the trend window, press the ◀ or the ◀◀ softkey.

To view later data than shown in the trend window, press the ▶ or the ▶▶ softkey.

### Viewing the Data for other Measurements

Use the scroll bar at the right side of the trend window to look at measurements that do not fit into the window.

- To move the highlight use the up and down arrows, or glide your finger along the TouchStrip.
- to scroll the window hold your finger on the up and down arrows, or glide your finger along the TouchStrip, and hold it at the top or the bottom of the TouchStrip.

---

## Printing and Recording the Trend Data

---

### Caution

---

Make sure that the printer or recorder is connected and switched on before you start printing or recording.

---

If you are already viewing the trend (see “Viewing the Trend” on page 272), you may need to press the **More** softkey to get the printing/recording softkeys.

If you need information about attaching a printer or recorder, see “Connecting a Printer” on page 335, or “Connecting a Local Recorder” on page 339.

### Printing the Page of Data from the Screen

Press the **Print Page** softkey. This will print the data on the screen, and will fill the page with trend data from before and after screen data.

### Printing a Set of Trend Data

There are two softkeys with data intervals and resolution for a printout shown on them

**Step 1.** Make sure the trend information you are interested in is in the window.

This information will be at the centre of the printout, assuming there is enough information before and after it.

**Step 2.** Press the softkey for the data interval you want to print (for example **Print 2h@1min**).

The duration and resolution of the data on the printout can be set by your biomedical engineer.

### Recording Trend Data

Press the **Record** softkey. This starts a recording of all parameters covering the time span of the trend data displayed on the screen.

## Erasing all the Trend Data

**Step 1.** Press the **Erase Trends** softkey. You will now be asked to confirm the deletion.

**Step 2.** If you are sure you want to delete the Trends, press the **Confirm** softkey. Otherwise press the **Cancel** softkey.

---

## Storing Events

You can store the current screen as an Event, with numerics, INOPs, and alarms and the last 20 seconds of wave data for all displayed waves.

### Storing an Event Manually

Press the **Store Screen** SmartKey (you may have to press ◀ or ▶ to find this SmartKey, if it is configured).



- You can store up to 10 events if the monitor has not stored any events automatically.
- If the monitor is configured to store events automatically, at least the five most recent manual events will always be kept.
- Manually storing an event might overwrite the oldest automatically-stored event, if more than five events have already been stored automatically.

### Inserting a Reference Signal in the Event

Immediately before storing the Event:

**Step 1.** Press the **Setup** key.

**Step 2.** Scroll down to **Calibration Signals**, and select it.

- A square wave signal with 1mV amplitude is inserted into any ECG wave;
- Two sawtooth signals with 1 Ohm amplitude are inserted into any RESP wave, and
- A stepped signal is inserted into any PRESS wave, with steps at 0, 20, 50, 100 and 150mmHg (0.0, 2.0, 5.0, 10.0, 15.0, 20.0kPa). The overall height of the PRESS reference signal depends on the label.

## Storing an Event Automatically

Setting up the automatic storage of events can only be done by the biomedical engineering department. See “Setting Up So that Events are Stored Automatically” on page 373

---

## Reviewing Events

To get the list of stored Events:

**Step 1.** Press the **Review Events** SmartKey (you may have to press ◀ or ▶ to find this SmartKey, if it is configured).



OR

**Step 1.** Press the **Setup** key.

**Step 2.** Select **Review Events** from the Setup menu.

Automatically recorded events are listed with the alarm message which triggered them, an arrow symbol next to the time means that there was more than one alarm at this time.

Symbol for more than one alarm

Symbol for kept event

Event Review			
Oct 03 20:16:05	**HR HIGH		Printed
Oct 03 19:44:17	***ASYSTOLE		Reviewed
Oct 03 19:10:48↑	**SpO2 LOW K		Printing
Oct 03 18:34:23	**TEMP HIGH		
Oct 03 17:00:00	Manual Event		Waiting
Oct 03 16:05:29	Manual Event		

## Keeping an Event for Future Reference

If necessary, you can store one event for future reference, without the risk of it being overwritten by new events. To do this, select the event and press the **Keep Event** softkey. K marks the currently kept event.

Each Event indicates whether it has been reviewed, printed or kept.

---

Note Because Events can be overwritten, the Event List cannot be regarded as a complete record of all the events that have occurred.

---

You can delete all of the Events by pressing the **Delete List** softkey. You will have to confirm that you want to delete the list by pressing the **Confirm** softkey.

### Reviewing the Numerics for an Event

**Step 1.** Highlight the Event you want to look at in the Event Review List.  
**Step 2.** Press the **Show Event** softkey.

Wave Indicator

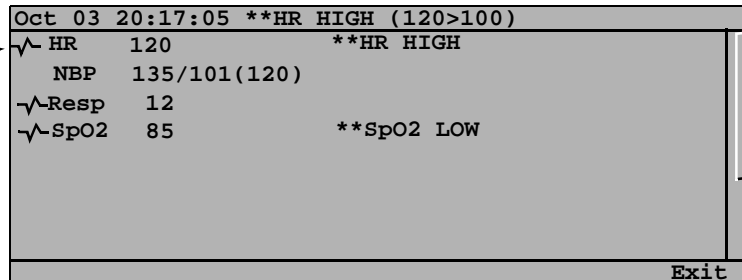

Events with a wave symbol to the left have wave strips associated with them (20 seconds). You can view a wave by highlighting that measurement and pressing the **Show Strip** softkey.

### Reviewing the Wave Strips for an Event

**Step 1.** Highlight the Event you want to look at in the Event Review List.  
**Step 2.** Press the **Show Strip** softkey.  
The first wave strip for the Event will be displayed. Press the **Next Strip** softkey to view the next wave stored with the Event.

To view other parts of the strip, press the ◀ or the ▶ softkey.

## Printing or Recording an Event

---

### Caution

---

Make sure that the printer or recorder is connected and switched on before you start printing.

---

**Step 1.** Highlight the Event you want to print or record in the Event Review List.

**Step 2.** If only a printer is available, press the **Print Event** softkey.

This prints the numerics and waves for the Event.

If only a recorder is available, the softkey **Record Event** will be visible. Press this softkey to record the selected event on the local recorder.

If both printer and recorder are available, press the **Print/Record** softkey to choose between printing or recording.

(If you need information about attaching a printer or recorder, see “Connecting a Printer” on page 335, or “Connecting a Local Recorder” on page 339.)

## Deleting an Event

**Step 1.** Highlight the Event you want to delete in the Event Review List.

**Step 2.** Press the **Delete Event** softkey.

## Deleting all the Events

**Step 1.** Press the **Delete List** softkey.

You will now be asked to confirm the deletion.

**Step 2.** If you are sure you want to delete the Events, press the **Confirm** softkey. Otherwise press the **Cancel** softkey.

## Stopping Printouts

### Stopping the Current Printout

- Step 1.** Press the **Setup** key.
- Step 2.** Move the highlight to **Printer**.
- Step 3.** Press on the strip to select the Printer window.
- Step 4.** Press the **Stop Printout** softkey

### Stopping All Printouts

- Step 1.** Press the **Setup** key.
- Step 2.** Move the highlight to **Printer**.
- Step 3.** Press on the strip to select the Printer window.
- Step 4.** Press the **Stop All** softkey
- Step 5.** Press the **Confirm** softkey.



# Cleaning

This chapter covers what you need to know to clean your monitor and accessories and how to keep your monitor in the best working condition.

- General Notes on Cleaning . . . . . 280
- Cleaning the Monitor, Server, Server Extension and Mounting. . . . . 286
- Cleaning, Disinfecting and Treating the Transducers for the Prevention of Cross Contamination . . . . . 287
- ECG Cables and Leads . . . . . 287
- NBP Cuff . . . . . 289
- PRESS Transducer . . . . . 292
- SpO<sub>2</sub> Transducer. . . . . 295
- TEMP Probes . . . . . 296
- Mainstream CO<sub>2</sub> Transducer and Reusable Airway Adapters . . . . . 297
- Microstream CO<sub>2</sub> (Sidestream) Accessories . . . . . 300

---

## General Notes on Cleaning

This Philips monitor (including the rubber bezel protector), together with its transducers and accessories can be cleaned, disinfected, or treated to prevent cross contamination using a variety of methods and substances. The recommended substances and methods listed in this chapter have been tested by Philips and you should use only these substances and methods to clean, disinfect and treat the equipment for the prevention of cross contamination. The use of other substances can cause stains or damage to the product.

To clean, disinfect and treat the transducers or accessories for the prevention of cross contamination, please refer to the specific instructions delivered with the product.

Damage caused by using substances or processes which have not been tested or approved by Philips will not be covered under warranty.

---

### Caution

---

After cleaning, disinfecting and treating for the prevention of cross contamination, check the monitor, transducers and accessories carefully. If there are signs of deterioration or damage, do not use them for further measurements.

---

---

---

### Warning

---

**Philips Medical Systems makes no claims regarding the efficacy of the listed chemicals or methods as a means for controlling infection. Consult your hospital's Infection Control Officer or Epidemiologist. For comprehensive details on cleaning agents and their efficacy refer to "Guidelines for Prevention of Transmission of Human Immunodeficiency Virus and Hepatitis B Virus to Health Care and Public-Safety Workers" issued by the U.S. Department of Health and Human Services, Public Health Service, Centers for Disease Control, Atlanta, Georgia, February 1989.**

---

---

## Cleaning

To keep your equipment free of dust and dirt, clean it with a lint-free cloth, moistened with either warm water (40°C/104°F. max) and soap, a diluted non-caustic detergent or one of the approved cleaning agents listed below.

**Cleaning Agents**

<b>Material Compatibility</b>	<b>Category</b>			
Product	Soap	Tensides	Ammonia based	Alcohol based
Monitor Measurement Server Mounting Hardware	yes	yes	yes	yes
ECG-Safety Trunk- Cables and purple non- shielded Lead Sets	yes	yes	yes	no
ECG one-piece cables	yes	yes	yes	yes
Reusable NBP Cuffs (Series M157X A) and NBP-Tubings	yes	yes	yes	yes
Reusable Invasive Pressure Transducer	yes	yes	no	no
Reusable Pulse Oximetry Transducer (Series M119X A)	yes	yes	yes	yes
Reusable Temperature Probes	yes	no	no	yes
Reusable M1460A CO <sub>2</sub> Transducer	yes	yes	no	yes
Reusable CO <sub>2</sub> Airway Adapter (M1465A/ 14360A)	yes	yes	no	no

### Recommended Cleaning Agents and Brands

<b>Soaps</b>	mild soaps
<b>Tensides</b> (dishwasher detergents)	Edisonite Schnellreiniger <sup>®</sup> , Alconox <sup>®</sup>
<b>Ammonias</b>	Dilution of Ammonia <3%, Window cleaner
<b>Alcohol</b>	Ethanol 70%, Isopropanol 70%, Window cleaner

---

#### Caution

---

To avoid damage to the product, observe the following general precautions for cleaning. You should only deviate when this is explicitly described in the cleaning instruction for the individual transducer or accessory.

---

---

- Do not use strong solvents such as acetone or trichloroethylene.
- Always dilute according to the manufacturers instructions, or use lowest possible concentration.
- Never use abrasive material (such as steel wool or silver polish).
- Do not allow liquid to enter into the product.
- Never submerge any part of the system.
- Do not pour liquid onto the system during cleaning.
- Do not allow cleaning agent to remain on any of the equipment surfaces - wipe it off immediately with a cloth dampened with water.

### Disinfecting

We recommend that you disinfect the product only when necessary as determined by your hospital's policy, to avoid long term damage to the product. We also recommend that the products being disinfected be cleaned first, as described under "Cleaning" on page 280

### Disinfecting Substances

Material Compatibility	Category				
	Alcohol based	Aldehyde based	Bleach	Iodine Based	Phenol based
Product					
Monitor Measurement Server Mounting Hardware	yes	yes	no	no	no
ECG-Safety Trunk-Cables and purple non-shielded Lead Sets	no	yes	no	no	no
ECG one-piece cables	yes	yes	no	no	no
Reusable NBP Cuffs (Series M157X A) and NBP-Tubings	yes	yes	no	no	no
Reusable Invasive Pressure Transducer	no	yes	no	no	no
Reusable Pulse Oximetry Transducer (Series M119X A) and Adapter Cables (M194XA)	yes	yes	no	no	yes
Reusable Temperature Probes	yes <sup>1</sup>	yes <sup>2</sup>	yes	no	no
Reusable M1460A CO <sub>2</sub> Transducer	yes	yes	yes	no	no
Reusable CO <sub>2</sub> Airway Adapter	yes	yes	yes	no	no

### Recommended Disinfecting Substances

<b>Alcohol based</b>	Ethanol 70%, Isopropanol 70% Cutasept <sup>®</sup> , Hospisept <sup>®</sup> , Kodan <sup>®</sup> , Tinktur forte, Sagrosept <sup>®</sup> , Spitacid <sup>®</sup> , Sterilium fluid <sup>®</sup> .  <i>Note</i> —only Ethanol 70% and Isopropanol 70% are tested and qualified
<b>Aldehyde based</b>	Dilution of formaldehyde (35-37%) Cidex <sup>®</sup> , Gigasept <sup>®</sup> .  <i>Note</i> —only Cidex is tested and qualified
<b>Bleach</b>	Dilution of sodium hypochlorite (laundry bleach); concentration ranging from 500ppm (1:100 dilution of household bleach) to 5000ppm (1:10 dilution of household bleach), Hydrogen peroxide 3%, Chlorox <sup>®</sup> (1:10 dilution), Dakin's Solution.
<b>Phenol based</b>	Wofasept <sup>®</sup> , Sporicidin <sup>®</sup> .

---

#### Caution

---

To avoid damage to the product, observe the following general precautions for disinfection. You should only deviate when this is explicitly stated in the disinfecting instruction of a specific product.

---

---

- Do **not** use Povodine<sup>®</sup>, Sagrotan<sup>®</sup>, or Mucocit<sup>®</sup>, Kohrsolin<sup>®</sup> disinfecting agents, or strong solvents.
- If you want to use a different substance or brand, verify the material compatibility in advance.
- Always dilute according to the manufacturers instructions or use lowest possible concentration.
- Do not allow liquid to enter the case.
- Never submerge any part of the system.
- Do not pour liquid onto the system during disinfection.
- Do not allow disinfecting agent to remain on any of the equipment surfaces - wipe it off immediately with a cloth dampened with water.

## Preventing Cross Contamination

We recommend that you treat for the prevention of cross contamination only when necessary as determined by your hospital's policy, to avoid long term damage to the product. We also recommend that the products being treated for the prevention of cross contamination be first cleaned as described under "Cleaning".

### Methods for Preventing Cross Contamination

Material Compatibility	Category			
	Autoclave	Gas (EtO)	Formaldehyde	Radiation
Product Monitor Measurement Server Mounting Hardware	no	no	no	no
ECG-Safety Trunk-Cables and purple non-shielded Lead Sets	no	yes	no	no
ECG one-piece cables	no	yes	no	no
Reusable NBP Cuffs (Series M157X A) and NBP-Tubings	no	yes	no	no
Reusable Invasive Pressure Transducer	no	yes	no	no
Reusable Pulse Oximetry Transducer (Series M119X A)	no	yes	no	no
Reusable Temperature Probes	no	yes	no	no
Reusable M1460A CO <sub>2</sub> Transducer	no	no	no	no
Reusable CO <sub>2</sub> Airway Adapter	yes	yes	no	no

#### Gas (EtO)

The recommended gas mixture is a 12%/88% ethylene oxide/freon 12 mixture.

---

**Caution**

---

Be sure all safety precautions regarding aeration after EtO exposure are followed.

The temperature used to prevent cross contamination must not exceed 60°C (140°F.).

Make sure the product is completely dry.; if not, it can result in the formation of ethylene glycol.

---

---

---

## Cleaning the Monitor, Server, Server Extension and Mounting

Clean the case with a lint-free cloth, moistened with water and soap, a diluted non-caustic detergent or one of the substances listed in “Cleaning” or “Disinfecting”.

Take extra care when cleaning the screen of the monitor because it is more sensitive to rough cleaning methods than the housing. Hewlett-Packard Display Cleaner (Part Number 8500-2163) is recommended for cleaning the screen.

---

**Caution**

---

Do not permit any liquid to enter the Monitor case and avoid pouring on the Monitor while cleaning.

Do not immerse any part of the equipment in liquid.

Water or cleaning solution must not enter the NBP connector of the Measurement Server, as this could damage the equipment.

Wipe around the connector socket, not over it.

---

---



---

## **Cleaning, Disinfecting and Treating the Transducers for the Prevention of Cross Contamination**

---

### **Caution**

---

Always follow the specific instructions delivered with the transducer if this is possible. This information may be more recent than the information given here. The information given in this chapter is intended as a guideline if the individual cleaning instructions are not available.

---

---

For material compatibility please refer to the “Cleaning Agents” on page 281, “Disinfecting Substances” on page 283 and “Methods for Preventing Cross Contamination” on page 285, or to the methods and substances proposed in the individual cleaning instructions.

---

## **ECG Cables and Leads**

---

### **Caution**

---

Always follow the specific instructions delivered with the transducer if this is possible. This information may be more recent than the information given here. The information given in this chapter is intended as a guideline if the individual cleaning instructions are not available.

---

---

Replace the cable if you see signs of deterioration or damage. Under these circumstances, do not use the cable for further patient monitoring.

### **Cleaning the ECG Cables**

To keep your cable free of dust and dirt clean it with a lint free cloth, moistened with either warm water (40°C/104°F maximum) and soap, a diluted non-caustic detergent or one of the approved cleaning agents listed below.

If you see signs of deterioration or damage, replace the cable do not use it for further patient monitoring.

***Recommended Cleaning Agents and Brands***

<b>Soaps</b>	mild soaps
<b>Tensides</b>	dishwasher detergents: Edisonite Schnellreiniger <sup>R</sup> , Alconox <sup>R</sup>
<b>Ammonias</b>	Dilution of Ammonia <3%, Windowcleaner
<b>Alcohol</b>	Ethanol 70%, Isopropanol 70%, Windowcleaner

**Disinfecting the ECG Cables**

We recommend that you disinfect the cable only when necessary as determined by your hospital’s policy, to avoid long term damage to the cable. We also recommend that the cable be cleaned first as described in “Cleaning the ECG Cables”.

***Recommended Disinfecting Substances***

<b>Alcohol based</b>	Ethanol 70%, Isopropanol 70%
<b>Aldehyde based</b>	Cidex <sup>R</sup>

**Treating the ECG Cables to Prevent Cross Contamination**

We recommend that you treat for the prevention of cross contamination only when necessary as determined by your hospitals policy, to avoid long term damage to the cable. We also recommend that the cable be cleaned first as described in “Cleaning the ECG Cables” on page 287.

The cable has been tested to withstand Ethylene Oxide (EtO) gas for the prevention of cross contamination. Be sure that all safety precautions regarding aeration after EtO exposure are followed.

---

**Caution**

---

Do not autoclave the cable or use bleaches containing sodium hypochlorite (for example, Clorox<sup>TM</sup>).

---

---

## NBP Cuff

---

### Caution

---

Always follow the specific instructions delivered with the cuff if this is possible. This information may be more recent than the information given here. The information given in this chapter is intended as a guideline if the individual cleaning instructions are not available.

---

---

### Cleaning the Disposable NBP Cuff

---

### Caution

---

Water or cleaning solution must not enter the NBP connector on the Measurement Server, as this could damage the equipment. When you are washing the cuff (or whenever it is disconnected) always fit the cap to the end of the rubber tube. This helps prevent liquid getting into the tubing accidentally, which could be sucked into the Measurement Server.

---

---

---

### Warning

---

**Disposable cuffs are single use devices, intended for use with one patient only. Do not use the same cuff on different patients.**

---

---

Disposable cuffs can be cleaned with soap solution to control infection.

Check the cuff and tubing. If there are signs of deterioration or damage, do not use for further patient measurements.

## **Cleaning and Treating the Reusable NBP Cuff for the Prevention of Cross Contamination**

These procedures apply only to the M1571A, M1572A, M1573A, M1574A, M1575A, and M1576A reusable cuffs.

---

### **Caution**

---

Water or cleaning solution must not enter the NBP connector on the Measurement Server, as this could damage the equipment. When you are washing the cuff (or whenever it is disconnected) always fit the cap to the end of the rubber tube. This helps prevent liquid getting into the tubing accidentally, which could be sucked into the Measurement Server.

---

---

Do not dry clean the cuff.

#### **To wash the cuff:**

- a. Remove the rubber bag.
- b. Wash the cuff in soapy water.
- c. Rinse the cuff and leave to air dry
- d. Reinsert the rubber bag (see below for instructions).

#### **To treat the cuff for the prevention of cross contamination:**

- a. Remove the rubber bag.
- b. Treat conventionally by autoclaving, gas or radiation sterilizing in hot air ovens, or by disinfection by immersion. The following recommended disinfectants may be used:
  - Cidex
  - Sporidicin
  - Microzid
  - Isopropyl alcohol 70%
  - Ethanol 70%
  - Buraton liquid
- c. If you treat the cuff for the prevention of cross contamination by immersion in a solution, allow the cuff to dry thoroughly.
- d. Reinsert the rubber bag (see below for instructions).

**To reinsert the bag in the cuff:**

**Step 3.** Roll the bag up from both sides in the direction of the tubing.

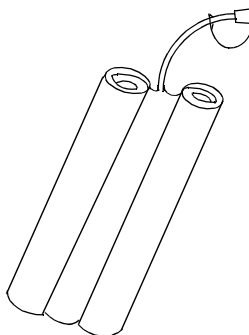

**Step 4.** Insert the rolled up bag, tubing first, into the opening on the short side of the cuff

**Step 5.** Push the tubing through the hole on the long side of the cuff.

**Step 6.** Hold the tube and the cuff and shake the complete cuff until the bag is in position.

**Step 7.** Check the cuff and tubing. If there are signs of deterioration or damage, do not use for further patient measurements.

---

---

## PRESS Transducer

---

### Caution

---

Always follow the specific instructions delivered with the transducer if this is possible. This information may be more recent than the information given here. The information given in this chapter is intended as a guideline if the individual cleaning instructions are not available.

---

---

### Cleaning the PRESS Transducer

---

### Caution

---

Do not reuse or treat disposable transducers or domes for the prevention of cross contamination.

---

---

**Step 1.** Remove the tubing and dome from the transducer.

**Step 2.** Wipe the transducer diaphragm with water.

---

### Caution

---

Do not immerse the connector in any liquid.

---

---

---

### Caution

---

Do not use acetone, alcohol, ammonia, chloroform or other strong solvents as these can damage the vinyl cabling.

---

---

**Step 3.** Taking care not to wet the connector, clean the transducer and cable by soaking and/or wiping them with soap and water, or a cleaning agent such as Cetylcide<sup>®</sup>, Wavicide-01<sup>®</sup>, Cidex<sup>®</sup>, Lysol<sup>®</sup>, or Vesphene<sup>®</sup>.

**Step 4.** Dry the transducer thoroughly before storing.

A slight discoloration or a temporary increase in the surface stickiness of the cable is normal.

**Step 5.** To remove any adhesive tape residue, use double seal tape remover (from the Scholl Mfg. Co.).

## Treating the PRESS Transducer for the Prevention of Cross Contamination

You can prevent cross contamination using liquid chemical or gas sterilization. Gas sterilization is described below.

### Liquid Chemical Sterilization

Select a sterilant that your hospital or institution has found to be effective for liquid chemical sterilization of operating room equipment, and one that does not damage the materials listed in the table below:

Do not use quaternary cationic detergents (such as zephiran chloride).

### Transducer Component Material

<b>Transducer component</b>	<b>Material</b>
Transducer housing	glass-filled polyester
Sensor	Fused quartz
Sensor adhesives	Silicone rubber, RTV
Cable insulation	polyvinyl chloride
Strain reliefs	Neoprene rubber
Connector shell	Glass-filled polyester
Connector insert	Glass-filled nylon, gold-plated pins
Cover seal	Silicone rubber
Screws	Stainless steel

Buffered glutaraldehyde (for example, Cidex or Hospisept) has been found to be effective.

**Step 1.** If the whole unit is to be treated for the prevention of cross contamination, make sure that the dome is removed, and immerse the transducer, but not the electrical connector, into the sterilant for the recommended treatment period.

**Step 2.** Rinse all transducer parts except the electrical connector with sterile water or saline solution.

**Step 3.** Dry the transducer thoroughly before storing.

**Step 4.** Check the transducer and cable. If there are signs of deterioration or damage, do not use the cable for further patient measurements.

### **Gas Sterilization**

For more complete asepsis, use gas sterilization.

If you are using ethylene oxide, make sure the transducer is completely dry. If the transducer is not completely dry, it can result in the formation of ethylene glycol.

For gases other than a 12% / 88% ethylene oxide/freon 12 mixture, consult the gas manufacturer for compatibility with the component materials of this transducer (see the table “Transducer Component Material” on page 293).

The sterilizer temperature must not exceed 70°C (158°F). Plastics in the pressure transducer may deform or melt above this temperature.

Follow the operating instructions provided by the manufacturer of the gas sterilizer.

Check the transducer and cable. If there are signs of deterioration or damage, do not use the cable for further patient measurements.



---

## SpO<sub>2</sub> Transducer

---

### Caution

---

Always follow the specific instructions delivered with the transducer if this is possible. This information may be more recent than the information given here. The information given in this chapter is intended as a guideline if the individual cleaning instructions are not available.

---

---

---

### Warning

---

**Do not reuse, or treat disposable SpO<sub>2</sub> transducers for the prevention of cross contamination. If the packaging of a sterile disposable transducer appears to be damaged, dispose of the transducer in the regular waste.**

---

---

---

### Caution

---

Do not autoclave the transducer.

---

---

---

### Caution

---

Do not immerse the transducer connector in liquid.

---

---

**Step 1.** Clean the transducer with a mild detergent solution, a salt solution (1%), or one of the following solutions:

Microzid (pure), Mucocit (4%), Incidin (10%), Cidex (pure), Sporicidin (1:16), Mucosol (3%), Buraton (pure), alcohol (pure), Alconox (1:84), Cetylcide (1:63).

Do not use bleaches containing Sodium Hypochlorite (for example, Clorox™).

**Step 2.** Wipe the transducer with a dry cloth, and leave to dry completely.

**Step 3.** Check the transducer and cable. If there are signs of deterioration or damage, do not use for further patient measurements.

---

## TEMP Probes

---

### **Caution**

---

Always follow the specific instructions delivered with the transducer if this is possible. This information may be more recent than the information given here. The information given in this chapter is intended as a guideline if the individual cleaning instructions are not available.

---

---

---

### **Warning**

---

**Do not reuse, or treat disposable temperature probes for the prevention of cross contamination.**

---

---

---

### **Caution**

---

Do not heat the temperature probe above 100°C (212°F).  
You can only subject the temperature probe to temperatures between 80°C (176°F) and 100°C (212°F) for short periods of time.  
Do not treat the probe in steam for the prevention of cross contamination.

---

---

Do not use a detergent that contains alcohol for disinfection.

Clean the probe by holding the tip with one hand, and with the other hand use a moist, lint-free cloth to rub the probe down in the direction of the connector.

Check the transducer and cable. If there are signs of deterioration or damage, do not use for further patient measurements.

---

## Mainstream CO<sub>2</sub> Transducer and Reusable Airway Adapters

---

### Caution

---

Always follow the specific instructions delivered with the transducer if this is possible. This information may be more recent than the information given here. The information given in this chapter is intended as a guideline if the individual cleaning instructions are not available.

---

---

### Cleaning the M1460A CO<sub>2</sub> Transducer

---

#### Caution

**The user must refer to the disinfectant manufacturer for procedures and information on effectiveness.**

---

**Step 1.** Wipe the transducer and cable with warm soapy water, Alconox, 70% isopropyl alcohol or 3% hydrogen peroxide and dry.

**Step 2.** Periodically check for cracks or deterioration.

**Step 3.** For more aggressive cleaning use the following procedure.

Clean the transducer with a soft brush and one of the following disinfecting agents prepared according to the manufacturer's recommendations:

- LpH®
- Cidex®
- Metricide 28®
- Edisonite®
- Mucocit-p 2000®
- Sagrotan K ®
- Commercial bleach, 1:10 dilution with water (see Note)

Rinse with water and soak in one of the above solutions for 20 minutes. Finally rinse with water and dry.

Note Do not immerse the connector end of the cable. Do not use ultrasonic cleaning. Do not use bleach on the Calstick

---

## **Treating the M1460A CO<sub>2</sub> Transducer for the Prevention of Cross Contamination**

---

### **Caution**

**The following are guidelines for treatment for the prevention of cross contamination. The effectiveness of the treatment should be confirmed by the user.**

---

Use the following procedure to treat the transducer for the prevention of cross contamination to a sterility assurance level of  $10^{-3}$ . This level of sterility assurance applies to the transducer and the cable. The Calstick and the connector exterior can be cleaned with the disinfectants listed in “Cleaning the M1460A CO<sub>2</sub> Transducer” on page 297

- Step 1.** Wipe down the transducer with 70% isopropyl alcohol.
- Step 2.** Soak the transducer for 10 minutes in Cidex or Metricide 28 prepared according to the manufacturer’s recommendations.
- Step 3.** Rinse the transducer in water, wipe and air dry.
- Step 4.** Soak the transducer for in Cidex or Metricide 28 according to the manufacturer’s recommendations.
- Step 5.** Rinse the transducer in sterile water and air dry.
- Step 6.** Follow hospital procedures for maintaining sterile equipment.

**Caution**

**Do not immerse the connector end of the cable. Do not autoclave, gas sterilize or heat the transducer or cables to temperatures above 70°C (158°F).**

---

**Note**

If you need to return a transducer to Philips Medical Systems, you must first decontaminate it.

---

**M1465A/  
14363A  
Airway  
Adapters**

- Step 1.** Immerse the airway adapter in warm soapy water for 5 minutes.
- Step 2.** Carefully brush the inside and between the windows using the small bristle brush provided (or equivalent - pipe cleaners or cotton swabs might also be useful).
- Step 3.** When the debris has been removed from both the inside and outside, rinse the adapter with clean water and air dry.
- Step 4.** Treat for the prevention of cross contamination (see below).
- 

**Caution**

**Do not use abrasive cleaning materials as these will damage the windows.**

**Do not use ultrasonic cleaning as this can weaken the bonds holding the windows in place.**

---

## Microstream CO<sub>2</sub> (Sidestream) Accessories

All Microstream™ accessories are **single-patient-use** only and may not be disinfected or treated for the prevention of cross contamination.

# Maintenance

This chapter covers what you need to know to keep your monitor in the best working condition.

- Maintenance Checks .....302

---

## Maintenance Checks

---

### Warning

---

**To avoid contaminating or infecting personnel, the service environment or other equipment, make sure the equipment has been appropriately disinfected and decontaminated before testing or maintaining it.**

---

### Recommended Maintenance Schedule

Maintenance	Frequency	Procedure
Inspect the system, cables and cords	Daily	See “Inspecting the Monitor, Measurement Server and Measurement Server Extension” on page 304, See “Inspecting the Cables and Cords” on page 305
Cleaning	As needed	See “Cleaning” on page 280
Safety checks according to IEC 60101-1	At least once every 2 years, after any repairs where the power supply is replaced or the monitor has been dropped, or as needed.	See the Service Guide
Synchronization of the monitor and defibrillator	Where applicable: At least once every 2 years, after any repairs where the monitor has been dropped, or as needed.	See the Service Guide



**Recommended Maintenance Schedule**

<b>Maintenance</b>	<b>Frequency</b>	<b>Procedure</b>
Functional testing procedures	When functional defects in the measurements are suspected.	See “Testing that the System Functions” on page 305
Performance Assurance (including Nurse Call Relay)	At least once every 2 years, or as needed (if you suspect the measurement values).	See the Service Guide
Replace backlight	25,000 hours (about 3 years) of continuous usage, or as needed	See the Service Guide
NBP Calibration (depending on National Laws)	Every year, or as needed	See the Service Guide
Temperature Calibration (depending on National Laws)	Every 2 years, or as needed	See the Service Guide
Sidestream CO <sub>2</sub> Calibration and Performance Test	At least once a year or after 4000 operating hours	See the Service Guide
Sidestream CO <sub>2</sub> Preventive Maintenance	At least once every 3 years or after 15,000 operating hours	See the Service Guide

All checks which require the instrument to be opened must be made by qualified service personnel. Safety and maintenance checks can also be made by Philips Medical Systems or your authorized supplier.

Contact your biomedical department whenever the monitor needs a safety, functional or performance test. These tests, and what to do if the instrument does not meet the specifications, are described in the Service Guide.

---

**Warning**

---

**Failure on the part of the responsible individual hospital or institution employing the use of this equipment to implement a satisfactory maintenance schedule may cause undue equipment failure and possible health hazards.**

---

---

## **Inspecting the Monitor, Measurement Server and Measurement Server Extension**

If you discover a problem while inspecting the monitor, the Measurement Server or the Measurement Server Extension, contact your biomedical department, Philips Medical Systems or your authorized supplier.

With the monitor switched off:

- Step 1.** Examine the exterior of the units for cleanliness and general physical condition.  
Make sure that the housings are not cracked or broken, that everything is present, that there are no spilled liquids and that there are no signs of abuse.
- Step 2.** Inspect the SmartRackLink and ensure that it is making good connection with the Measurement Server, or the Measurement Server cable.
- Step 3.** If the Measurement Server (and Server Extension, if in use) are mounted on the monitor, make sure that they are locked into place and do not slide out without releasing the locking mechanism on the back of the monitor.
- Step 4.** Inspect all accessories (cables and transducers) external to the monitor and the Measurement Server/Server Extension, referring to the manufacturer's documentation.
- Step 5.** Switch the monitor on and make sure the backlight is bright enough. Check that screen is at its full brightness ("Adjusting the Screen Brightness" on page 47) and remember that the brightness is reduced automatically if you are powering the monitor from the battery. If the brightness is not adequate, contact your biomedical department or your supplier. Philips recommends replacing the backlight every 3 years of continuous use.

## Inspecting the Cables and Cords

If you discover a problem while inspecting the cables and cords, replace the cable, or contact your biomedical department, or your supplier.

**Step 1.** Examine the power plug and cord for damage

Make sure that the prongs of the plug do not move in the casing.

If damaged, replace the entire cord with the appropriate Philips Power Cord.

**Step 2.** If the Measurement Server is not mounted directly on the monitor, inspect the cable connecting it to the monitor.

Make sure that there are no breaks in the insulation.

Make sure the connectors are properly engaged.

**Step 3.** Inspect the patient cables and leads and their strain reliefs for general condition.

Make sure there are no breaks in the insulation.

Make sure that the connectors are properly engaged at each end to prevent rotation or other strain.

**Step 4.** With transducer or electrodes applied to the patient, and the monitor switched on, flex the patient cables near each end to make sure that there are no intermittent faults.

---

### **Warning**

---

## Testing that the System Functions

**During this test, the monitor is not making any patient measurements, measurement results are not collected, and patient alarms are not active.**

**If you need to stop the test, select `Test Signals` in the Setup menu a second time.**

---

**Step 1.** Make sure that the Measurement Server is connected to the monitor, and the monitor is switched on.

**Step 2.** Press the **Setup** key.

**Step 3.** Move the highlight to **Test Signals**.

**Step 4.** Press on the strip.

## Maintenance Checks

Check that you see:

<b><u>Measurement</u></b>	<b><u>Test Signal</u></b>
<b>ECG Wave</b>	Artificial ECG Wave.
<b>ECG Numeric</b>	<i>Adult:</i> 100bpm $\pm$ 2 <i>Neo/Pedi:</i> 125bpm $\pm$ 2
<b>RESP Wave</b>	Square Wave.
<b>RESP Numeric</b>	<i>Adult:</i> 15bpm $\pm$ 2 <i>Pedi:</i> 30bpm $\pm$ 2 <i>Neo:</i> 55bpm $\pm$ 2
<b>Pressure Wave</b>	Square wave, Pulse = 100, from 0 to 120mmHg [from 0 to 15kPa]
<b>Pressure Numeric</b>	<i>Adult:</i> 120/0 (60) $\pm$ 1mmHg (15.0/0.0 (7.5) $\pm$ 0.1kPa) Pulse: 100 <i>Pedi/Neo:</i> 60/0 (30) $\pm$ 1mmHg 6.0/0.0 (3.0) $\pm$ 0.1kPa Pulse: 125
<b>Plethysmograph</b>	Simulated Pleth Wave, Pulse = 60
<b>CO<sub>2</sub> Wave</b>	Square wave from 0 to 40 mmHg (0 to 5 kPa on M3016A, 5.3 kPa on M3015A)
<b>CO<sub>2</sub> and AwRR Numerics</b>	EtCO <sub>2</sub> : 40 mmHg (5.0 kPa on M3016A, 5.3 kPa on M3015A) ImCO <sub>2</sub> : 0 mmHg (0.0 kPa) AwRR: 20 rpm

<u>Measurement</u>	<u>Test Signal</u>
<b>SpO<sub>2</sub> Numeric</b>	100% <i>Pulse:</i>
	60bpm±1
<b>NBP Numeric</b>	<i>Adult:</i>
	120/80 (90) (16/10.5 (12))
	<i>Pedi:</i>
	100/60 (80) (13.3/8 (10.7))
<b>TEMP Numeric</b>	40°C±0.1°C (104.0°F±0.2°F)

**Step 5.** If you do not see these results for the measurements that are on, contact your biomedical department.

**Step 6.** Exit the Setup menu.

## Finding Intermittent Status

If you suspect that some condition is arising intermittently on your monitor, you can check the Status Log by

**Step 1.** Press the **Setup** key.

**Step 2.** Move the highlight to **Status Log**.

**Step 3.** Press on the strip.

A list of all saved conditions which occurred for the monitor is shown.

To check the status log for the Measurement Server, press the **MeasServ Stat Log** softkey

To print the current status log, press the **Print Stat Log** softkey.

To clear the status log, press the **Clear Stat Log** softkey.

If the status log is already full, the oldest message is discarded when another condition is saved.

**Step 4.** Exit the Setup menu.

## Testing Visual and Auditory Alarms

- Step 1.** Switch on the monitor, with no ECG cable connected.
- Step 2.** Switch main alarms on if alarms are suspended.
- Step 3.** Enter the ECG Setup window. If ECG is off and/or alarms are off, switch on ECG and alarms.
- Step 4.** Check that the ECG **leads OFF** INOP is displayed in the upper left corner of the screen and an alarm tone sounds.
- Step 5.** Press Silence/Reset and check that the alarm tone disappears.

# Using Your Monitor in Patient Transport

This chapter covers what you need to know to use your monitor for patient transport.

- Using a Vehicle 12V Supply .....310
- Using New Batteries.....310
- Maintaining the Battery .....311
- Troubleshooting Battery Operation .....314

## Using a Vehicle 12V Supply

If you have an M3080A #C32 12V Adapter, you can run the monitor from a vehicle 12V supply. Refer to the documentation delivered with the adapter for details about connection to the monitor.

---

## Using New Batteries

---

### **Caution**

You should only use batteries of the type Toshiba TR36 or Moltech NJ1020. These can be ordered as M3080A #C40 or under the part number M3046-61302 (or purchased commercially, if available).

Remove the battery from the monitor if it is not used regularly. Keeping it in the monitor without using it may increase battery aging significantly.

Keep unused batteries outside the monitor and recharge them every 3 to 4 months.

---

---

Initialize a new battery by pressing on the button below the charge LEDs until the LEDs light.



---

## Maintaining the Battery

### Finding Out How Much Charge is in the Battery

**If you are using the monitor from the battery.**

The battery gauge is displayed in the right hand, bottom corner of the screen. The white area to the left of the gauge indicates the charge: the greater the area to the left, the greater the remaining charge.

**If you have the battery out of the monitor.**

On the bottom of the battery, beside the connector there are four LEDs. Between these LEDs and the connector there is a button. Press this button and the LEDs will light to indicate the charge in the battery.

**If you are operating the monitor from an ac power source.**

The Battery LED has three colors, the first two are:

**green**

Battery full (>95% charged).

**yellow**

The battery is charging.

**If you are NOT operating the monitor from an ac power source.**

The third color of the Battery LED is:

**flashing red**

The battery is nearly empty, 5 minutes operating time remains.

If the battery is very empty, this LED will flash red once when you press the **On-Off/Standby** button.

## Finding Out How Much Operating Time Remains

A new, fully charged battery operates for two and a half hours, unless you are using a lot of power (such as by measuring NBP more often than every 15 minutes). Older batteries may not have as much capacity.

To find out how much time remains,

**Step 1.** Press the **Setup** key.

**Step 2.** Move the highlight to **Battery**.

**Step 3.** Press on the strip.

A window will open displaying the full details on the current condition of the battery.

## Changing the Battery

### Removing a battery:

**Step 1.** Slide the battery compartment door toward the rear of the monitor, and open it down.

**Step 2.** Locate the tape and pull the battery out.

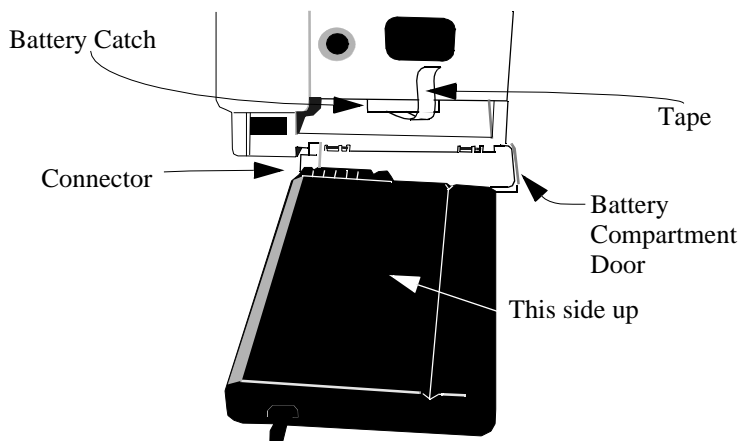

**Inserting a battery:**

With the battery door open

- Step 3.** Orient the battery with the groove up and the connector to the left (as shown on the inside of the battery compartment door).
- Step 4.** Make sure the tape is laid properly on the top of the battery.
- Step 5.** Insert the battery into the compartment and slide it in until the catch clicks into place over the end of the battery.
- Step 6.** Close up the battery door and slide it toward the front of the monitor until it clicks into place.

**If the Battery is Discharged (Flat)**

If available, use the M3080A #C30 Battery Charger to recharge the batteries. If not:

- Step 1.** Insert the battery into a monitor that is not currently being used for transport purposes.
- Step 2.** Make sure the monitor is connected to the a.c. power supply.
- Step 3.** Charge the battery until it is full (the battery LED is green, or the battery gauge shows the battery is full).  
This will take approximately 4 hours with the monitor switched off, or approximately 24 hours with the monitor switched on.

**If the Battery Needs Conditioning**

You should condition the battery

- before you use the battery for the first time
- approximately every 50th time you recharge it
- whenever the battery discharges quickly from full.
- when indicated by the battery status indicator:

Although the battery status indicator tells you  that it is time to condition the battery, it also shows how much capacity there is left in the battery for monitoring (represented by the grey bar).

Use a different battery for continued monitoring. You cannot condition a battery in a monitor that is being used.

- Step 1.** Insert the battery into a monitor that is not currently being used.
- Step 2.** Disconnect the monitor from the a.c. power supply.
- Step 3.** Turn on the monitor, until the monitor switches off automatically.
- Step 4.** Turn the monitor off using the **On Off/Standby** switch.
- Step 5.** Reconnect the monitor to the a.c. power supply.
- Step 6.** Charge the battery until it is full (the battery LED is green).
- Step 7.** Repeat steps 2 to 6.

You could also use the M3080A #C30 Battery Charger to charge the battery.

---

## Troubleshooting Battery Operation

### Understanding the Battery LED

The Battery LED is at the bottom right of the monitor.

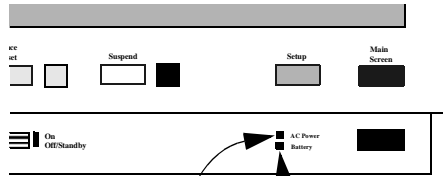

**AC Power LED**  
Green when AC Power is Connected

**Battery LED**  
**Green** - Battery full (>95%)  
**Yellow** - Battery charging  
**Blinking Red** - Battery empty

The LED has three colors:

- |                        |   |
|------------------------|---|
| <b>green</b>           | Battery full (>95% charged). This LED only lights green while the monitor is connected to an AC power supply.   |
| <b>yellow</b>          | The battery is charging. This LED only lights yellow while the monitor is connected to an AC power supply.  |
| <b>flashing red</b>    | The battery is nearly empty, 5 minutes operating time remains.<br>If the battery is very empty, this LED will flash red once when you press the <b>On-Off/Standby</b> button.   |
| <b>yellow flashing</b> | The communication between the battery and the monitor is not working. Allow up to 30 minutes for this status to change — a fully discharged battery needs to charge to a certain level before it can communicate its status. If the status does not change, or if you cannot wait 30 minutes, change the battery. This LED only lights yellow while the monitor is connected to an a.c. power supply. |

## Understanding Messages in the Battery Gauge

If the word **Malfunction** is displayed in the gauge, change the battery at the first opportunity. This indicates that the status of the battery cannot be determined.

If the word **Cond. Battery** is displayed in the gauge, replace the battery at the first opportunity. This indicates that the battery needs to be conditioned, contact your biomedical department. (See also “If the Battery Needs Conditioning” on page 313).

You might also get this message for a battery which has been left in a monitor that is connected to the a.c. power for a number of days.

## Understanding Battery Technical Alarms (INOPs)

Check at the top left of the screen for a technical alarm message (an INOP).

### BATTERY LOW

Change the Battery.

*Note*—This INOP arises when the battery has approximately 20 minutes charge left.

### BATT. MALFUNCT.

Change the battery at the first opportunity.

If you get this message with a new battery, try initializing the battery by pressing on the button below the charge LEDs until the LEDs light.

*Note*—This INOP arises when the status of the battery cannot be determined.

In the case of a new battery, this means that the communication between the battery and the monitor is not working. Allow up to 30 minutes for this status to change, with the monitor connected to the a.c. supply — a fully discharged battery needs to charge to a certain level before it can communicate its status. If the status does not change, or if you cannot wait 30 minutes, change the battery.

**BATTERY EMPTY**

Change the Battery.

*Note*—This INOP arises when the battery has less than 5 minutes charge left.

# Installing Your Monitor

This chapter covers what you need to know to get the monitor working,.

In addition, this chapter covers connecting your monitor to a printer or recorder.

- Warnings and Precautions .....318
- Preparing to Install Your Monitor .....318
- Installing Your Monitor .....325
- Connecting a Printer .....335
- Connecting a Local Recorder .....339
- Disposing of the Monitor, Measurement Server and Measurement Server Extension .....343

---

## Warnings and Precautions

This section contains important information on patient safety and installation requirements for the monitor.

### Patient Safety

See “Monitor and Measurement Server Safety Specifications” on page 394.

### Patient Leakage Current

The patient leakage current is less than 10 $\mu$ A at 230V/50Hz. The equipment has floating inputs (Type CF) and are protected against the effects of defibrillation and electrosurgery.



The heart symbol signifies that the applied parts and their components are of Type CF and defib. proof according to IEC60601-1/EN60601-1.

---

## Preparing to Install Your Monitor

---

### Warning

---

**To avoid contaminating or infecting personnel, the service environment or other equipment, make sure that equipment which has been used before has been appropriately disinfected and decontaminated.**

---

---

### Power Source Requirements

See “Electrical Specifications” on page 395.



## **Protecting against Electric Shock**

The M3046A Monitor is classified as Class I Equipment with an internal power source according to IEC 60601-1/EN 60601-1/CSAC22.2 601.1/UL 2601-1, which means an instrument included in the protective grounding (protective earth) system of the room by way of grounding contacts in the power plug.

To protect the patient and hospital personnel, when operating from an AC source, the cabinet of the monitor must be grounded. The monitor is equipped with a detachable 3-wire cable which grounds the instrument to the power line ground (protective earth) when plugged into an appropriate 3-wire receptacle.

---

### **Caution**

---

The monitor uses DOUBLE POLE/NEUTRAL FUSING.

---

---

---

### **Warning**

---

**Disconnect the monitor from the ac source by unplugging the power cable from the ac source receptacle or from the ac power connector at the side of the monitor.**

**The On/Off Standby button does not disconnect the monitor from the ac source.**

---

---

---

### **Warning**

---

**Do not operate the M3046A monitor on a 2-wire AC supply.**

---

---

Connect the grounding wire to the equipotential grounding post on the monitor.

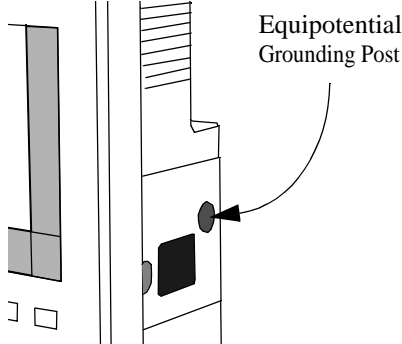

## Equipotential Grounding



To eliminate potential differences between different pieces of equipment, for internal examinations on the heart or the brain, the monitor must have a separate connection to the equipotential grounding system.

One end of the equipotential grounding cable (potential equalization conductor) is connected to the equipotential grounding post on the side of the instrument and the other end to one point of the equipotential grounding system.

Examinations in or on the heart (or brain) should only be carried out in medically used rooms incorporating an equipotential grounding system.

## Combining Equipment

All combinations of medical equipment with non-medical equipment must comply with IEC 60601-1-1.

---

### Warning

---

**If instruments are combined, the summation of the leakage currents can be hazardous to the patient or hospital personnel.**

---

Apart from the possible danger caused by leakage currents, no other hazards are known to result from the simultaneous use of the Monitor with other patient connected equipment.

If it is not evident from the instrument specifications whether a particular instrument combination is hazardous or not, for example due to summation of leakage currents, the user should consult the manufacturers concerned, to ensure

that the necessary safety of all instruments concerned will not be impaired by the proposed combination.

## **Environment**

To ensure a completely safe electrical installation, follow the instructions described later in “Installing Your Monitor” on page 325. The environment where the system will be used should be reasonably free from vibration, dust, corrosive or explosive gases, extremes of temperature, humidity, and so on.

Allow at least 2 inches (5cm) clearance around the instruments for proper air circulation.

For a cabinet mounted installation, allow sufficient room at the front for operation and sufficient room at the rear for servicing with the cabinet access door open.

The monitor operates within specifications at the ambient temperatures shown in the tables given in “Monitor Environmental Specifications” on page 395, and “Measurement Server Environmental Specifications” on page 399, approximately 15 minutes after switch on.

Ambient temperatures that exceed these limits could affect the accuracy of the monitor and cause damage to the components and circuits.

Make sure that during operation, the instrument is free of condensation. Condensation can form when equipment is moved from one building to another, thus being exposed to moisture and differences in temperature.

---

---

### **Warning**

---

---

**Possible explosion hazard if used in the presence of flammable anesthetics.**

---

---

## Explanation of symbols used:



Standby for switching the monitor on and off.



Attention, consult accompanying documents.



*On the Measurement Server:* Defib Data In, that is the ECG marker pulse sent from the defibrillator to the monitor. The marker pulse is then processed with the ECG signal and displayed on the monitor.

*On the M3015A Measurement Extension:* Gas Inlet



*On the Measurement Server:* ECG Data Out is the analog ECG signal sent out from the monitor to a defibrillator or other external device, such as an intra-aortic balloon pump.

*On the M3015A Measurement Extension:* Gas Outlet/Exhaust

*On the Monitor:* Data Output to serial recorder



Serial interface socket for connection to recorder (option #J16 only)



Alternating Current



Equipotential Grounding Post (see “Equipotential Grounding” on page 320)

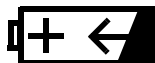

Battery Compartment



Type CF Applied Part and **defibrillator proof** with special protection against electric shocks for intracardiac application (regarding allowable leakage currents by having an F-Type isolated or floating section).



Class 2 Radio equipment identifier (1999/5/EC)

The following are the markings on the back of the monitor (M3046A):

This device complies  
with FCC part 15  
of the FCC rules.  
Operation is subject to  
the following two conditions:  
(1) this device may not  
cause harmful interference.  
and  
(2) this device must accept  
any interference received,  
including interference that  
may cause undesired  
operation.

Prod No. M3046A Opt.



**PHILIPS**

SN: XXXXXXXXXXXX



Radio module inside  
FCC ID IMKRL2630M

CLASS 1  
LASER  
PRODUCT

D-71034 Boeblingen, Germany

Made in  
Germany  1999-02



The printer port uses LED devices for infrared communication with the printer. These LED devices are measured to be AEL Class 1 LED Products per IEC 825-1 and CENELEC EN60825-1 Standards.

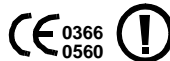

The Philips M3046A Compact Portable Patient Monitor complies with the requirements of the Council Directive 93/42/EEC of 14 June 1993 (Medical Device Directive) and Council Directive 1999/5/EC of 9 March 1999 (Radio and Telecommunications Terminal Equipment Directive).

The following are the markings on the back of the measurement server:

*SpeedPoint*  
technology

Prod No. M3001A



SN: XXXXXXXXXXXX



Opt: XXX XXX XXXXXXX



**PHILIPS** M3001A

D-71034 Boeblingen Germany



Made in  
Germany

**CE**<sub>0366</sub> The Philips M3001A Multi-Measurement Server complies with the requirements of the Council Directive 93/42/EEC of 14 June 1993 (Medical Device Directive).

The following are the markings on the back of the measurement server extensions (M3015A/M3016A):

Prod No. M301XA



SN: XXXXXXXXXX



Date of Manufacture: MM/YY

Made in Germany



**PHILIPS** M301XA

D-71034 Boeblingen Germany



**CE**<sub>0366</sub> The Philips M3015A and M3016A Measurement Server Extensions comply with the requirements of the Council Directive 93/42/EEC of 14 June 1993 (Medical Device Directive).

---

## Installing Your Monitor

### Unpacking the Monitor

The box containing your monitor comes with

- This User Guide
- The Monitor
- A Power Cord

The box containing your Measurement Server contains only the measurement server.

In addition you should receive all of the options and accessories that you have ordered.

If anything is missing, contact your Philips representative immediately.

If anything has been damaged in transit, keep the packing material for inspection and contact your Philips representative immediately.

Do not use the monitor if the casing has been damaged.

If the monitor is damaged, make sure that the screen is not leaking. There is no known danger from the fluid of irritation to skin or eyes, or by inhalation. The median lethal dose if taken orally is 2.0g/kg.

There are no special procedures necessary for cleaning spilled fluid.

## Installing the Monitor

For information about mounting the monitor, see the Installation and Service Guide.

---

### Caution

---

**Avoid placing the monitor or measurement server underneath an infusion bag.**

**Make sure that infusion liquid cannot get into any of the Measurement Server or monitor connectors.**

---

---

To install the monitor you must make sure it has an adequate power supply (see “Preparing to Install Your Monitor” on page 318 for information about AC power, and “Using Your Monitor in Patient Transport” on page 309 for information about using batteries).

Switch the monitor on using the **On/Off Standby** button.

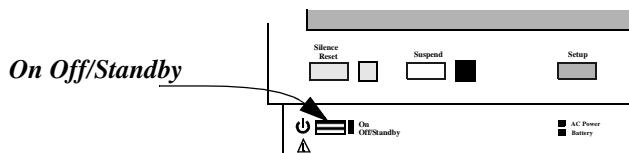



## Connecting the Measurement Server...

### ...with the Measurement Server directly on the Monitor

You can connect the Measurement Server to the monitor by mounting it directly on the monitor:

**Step 1.** Make sure that your monitor has a link bar:

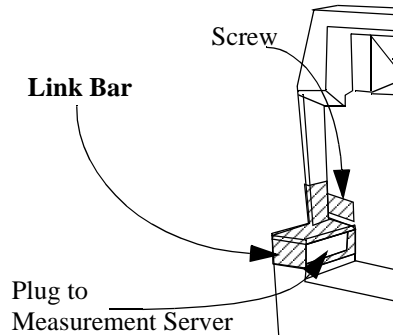

If your monitor does not have a link bar,

- a. Position the link bar as shown in the diagram above. Make sure that the guide is in the slot under the plug (which connects to the Measurement Server).
- b. Press the Link Bar into position, until it clicks.
- c. Tighten the screw into the back of the monitor.

**Step 2.** Place the Measurement Server on the back of the monitor.

If it is not tight against the back of the monitor, slip it away from the link bar until it is.

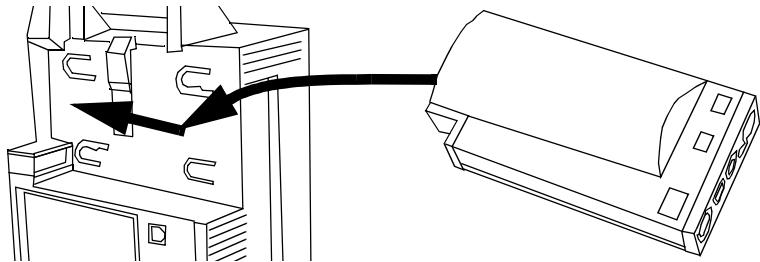

**Step 3.** Slip the Measurement Server forward until it clicks into place.

## Installing Your Monitor

To remove the Measurement Server from the monitor, move the latch (in the middle at the top of the monitor) toward the front of the monitor, and slide the

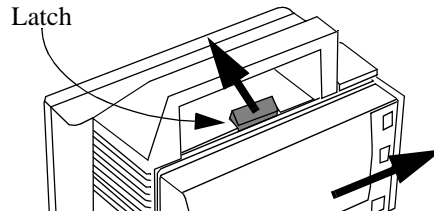

Measurement Server away from the link bar.

### **...with the Measurement Server Separate from the Monitor**

You can connect the Measurement Server to the monitor using a server link cable:

**Step 1.** You can connect the cable to the plug on the link bar, or directly to the monitor:

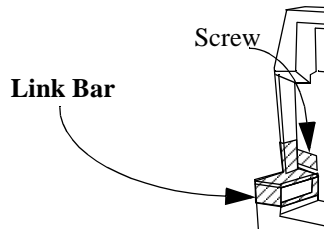

To remove the link bar,

- a. Unscrew the link bar from the back of the monitor.
- b. Lift the tab that was screwed to the monitor.
- c. Slide the link bar away from the monitor.

**Step 2.** Attach the socket end of the cable to the monitor.

**Step 3.** Attach the other end of the cable to the Measurement Server.

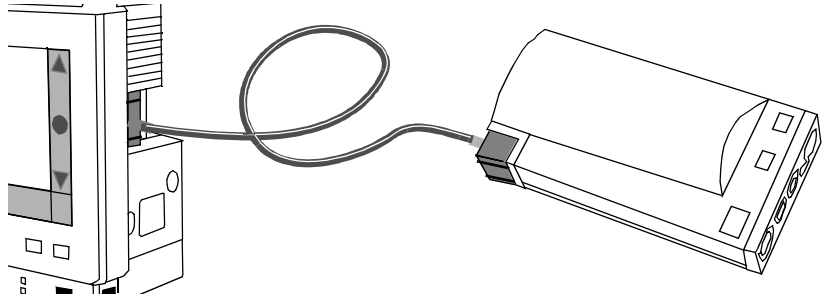

**...with the Measurement Server Remote from the Monitor**

You can connect the Measurement Server to the monitor using cables and wall sockets which allow the monitor to be in a different room than the Measurement Server (up to 25m apart). The two wall sockets are installed in the wall and connected to each other by cable:

**The monitor is connected to the first wall socket**

**Step 1.** You can connect the cable to the plug on the link bar, or directly to the monitor.

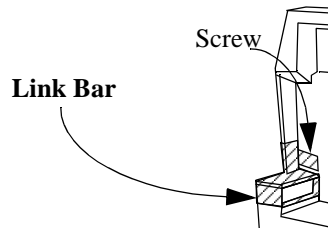

**Step 2.** Plug the other end of the cable into the wall socket.

**The Measurement Server is attached to the second wall socket**

**Step 3.** Plug the end of the cable into the wall socket.

**Step 4.** Connect the other end of the cable to the Measurement Server

**Attaching the Monitor to a Mount**

**Step 1.** Make sure the front of the monitor is facing the front of the mount. The front of the mount has a blue button in the center.

**Step 2.** Lower the monitor onto the mount, until the feet of the monitor click into the mount.

**Detaching the Monitor from a Mount**

- Step 1.** Press and hold in the blue button on the front of the mounting.
- Step 2.** Lift the monitor away from the mount.

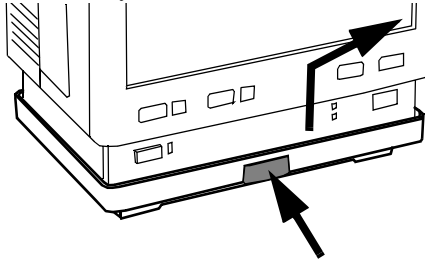

- Step 3.** Release the blue button.

**Attaching the Measurement Server to a Mount**

- Step 1.** Make sure the Measurement Server is oriented correctly relative to the mount (see the picture below).
- Step 2.** Place the Measurement Server on the back mount.  
If it is not tight against the mount, slip it in the direction of the measurement connectors until it is.
- Step 3.** Slip the Measurement Server forward until it clicks into place.

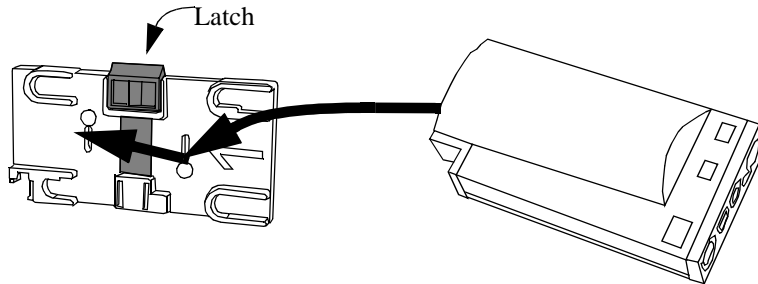

**Detaching the Measurement Server from a Mount**

- Step 1.** Press and hold the latch (in the middle at the top of the mount) away from the Measurement Server.
- Step 2.** Slide the Measurement Server off the mount in the direction of the measurement connectors.

**Positioning the Measurement Server on a Clamp Mount**

If you have your Measurement Server on the clamp mount, you can have it in one of four positions. You can reposition it as follows:

**Step 1.** Press and hold the mount latch toward the clamp screw.

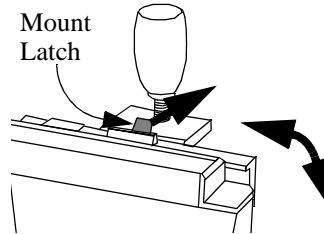

**Step 2.** Rotate the Measurement Server and mount until you get it to the position you want.

**Step 3.** Release the mount latch, and make sure it is clicked into one of the four slots on the back of the mount.

## Connecting to the Information Center

For information on connecting to the Information Center, see “Communicating with the Information Center” on page 105.

## Connecting to the Nurse Call Relay

---

### **Warning**

---

**Do not rely exclusively on the Nurse Call Relay for the notification of alarm conditions.**

**The relay output cannot be checked by the monitor, and the monitor cannot notify the user of any failure of the relay.**

---

See the specifications for the Nurse Call Relay in “Interfaces” on page 396, and the documentation for the device you are connecting.

## Connecting to the ECG Output or Marker Input

See the specifications for the ECG Output and for the Marker Input in “Interfaces” on page 396, and the documentation for the device you are connecting.

## Using an Additional Display

The M3046A Monitor can be used with an additional display as required. The information displayed on the additional display is identical to that on the monitor display.

---

### Caution

**The size and speed of the waveforms may differ from the specification for the M3046A due to the different display size.**

---

### Displays

Any display which meets the specifications for the VGA interface (see “Monitor Performance Specifications” on page 396) may be used with your monitor. These displays must either:

- comply with IEC-60601-1 (spilling proof, enclosure leakage current, fixed power cable if isolation transformer used), when used in the patient vicinity, **or**
- comply with IEC 60601-1-1 and be used with an isolation transformer (e.g. M1389A), when used outside the patient vicinity.

### Installation

An additional display must be installed by a Philips Medical Systems service engineer or authorized Service Representative. By the addition of a display, the M3 monitor becomes a “system” and must be safety-tested as such after installation. Detailed information about installation and the required safety testing can be found in the Service Guide.

### Safety Specification

Enclosure leakage current for the combination of M3046A monitor, additional display and isolation transformer (where required, see “Displays” on page 332) must meet the following requirements:

<b>IEC 60601-1</b>	500 microamps ( $\mu$ A) rms at 264V, 50/60 Hz
<b>UL 2601-1</b>	300 microamps ( $\mu$ A) rms at 240V, 60 Hz
<b>CSA C22.2 #601-1</b>	500 microamps ( $\mu$ A) rms at 264V, 50/60 Hz

## Basic Troubleshooting

The following is a list of some cases where the user can correct the fault. If the fault is not described below, it should be investigated by your technical personnel as soon as possible.

### Self Test Alarm Messages (When You Switch the Monitor On)

Message	What To Do
Battery Low (approx. 20 minutes remaining)	Connect to AC power to charge the battery, or fit a fully charged battery, within next 15 minutes.
Check Status Log	This indicates a “non-critical” problem in the monitor. There is a defect but you can still use the monitor. The monitor should be investigated by your technical personnel as soon as possible.
ECG EQUIP MALF	Measurement defective. Exchange the Measurement Server. The Measurement Server should be investigated by your technical personnel as soon as possible.
NBP EQUIP MALF	Measurement defective. Exchange the Measurement Server. The Measurement Server should be investigated by your technical personnel as soon as possible.
Pressure Zero & Check Cal	Pressure must be zeroed, or calibration required. Zero the Pressure, or check the calibration. If unsuccessful, exchange the Measurement Server.
PRESS EQUIP MALF	Measurement defective. Exchange the Measurement Server. The Measurement Server should be investigated by your technical personnel as soon as possible.
RESP EQUIP MALF	Measurement defective. Exchange the Measurement Server. The Measurement Server should be investigated by your technical personnel as soon as possible.
SpO <sub>2</sub> EQUIP MALF	Measurement defective. Exchange the Measurement Server. The Measurement Server should be investigated by your technical personnel as soon as possible.
TEMP EQUIP MALF	Measurement defective. Exchange the Measurement Server. The Measurement Server should be investigated by your technical personnel as soon as possible.

**Self Test Alarm Messages (When You Switch the Monitor On)**

<b>Message</b>	<b>What To Do</b>
CO <sub>2</sub> EQUIP MALF	Incompatible hardware or software revision or measurement defective. Exchange the Measurement Server Extension. The Measurement Server Extension should be investigated by your technical personnel as soon as possible.
BAD SERVER LINK	This combination of Monitor, Measurement server and cable cannot be used
BAD SERVER LINK plus “Measurement Server Revision not supported” status message in red.	An M3000A Measurement Server with revision A software is connected to an M3046A Monitor. This combination does not allow monitoring.
“Some measurements are not supported by the Monitor” prompt message	A Measurement Extension (M3015A or M3016A) is connected to an M3046A M3 monitor. Some measurements from the Measurement Extension are not available.
“Measurement Server Configuration not supported” status message	An unsupported Measurement Extension is connected to a standard M3001A Measurement Server.
“Some measurements in MMS Extension are not supported” prompt message	The M3046A Monitor does not support some of the measurements in a Measurement Extension.

**Troubleshooting when there is No Message on the Screen**

<b>Symptom</b>	<b>Possible Cause</b>	<b>What To Do</b>
Some or all of the numerics or the waves are missing from the screen.	No measurements connected	Check that a Measurement Server and all the required transducers are connected. Connect a Measurement Server
	No transducers connected	Connect the required transducers.
	Defective transducer	Replace the suspect transducer.



### Troubleshooting when there is No Message on the Screen

Symptom	Possible Cause	What To Do
	Measurement Server defective	Exchange the Measurement Server. The Measurement Server should be investigated by your technical personnel as soon as possible.
Monitor screen “dim”	Brightness controls not properly adjusted	Adjust brightness controls. The screen may not be as bright when the monitor is operating from the battery.
Monitor screen blank	Power not connected or switched on	Connect power and switch on the monitor.
	Battery not installed or empty (Battery LED flashes red, or flashes red when you press the <b>On-Off/Standby</b> switch.)	Fit a charged battery and switch on the monitor.

## Connecting a Printer

### Selecting a Printer

If you are printing locally, you can use either:

an HP DeskJet 610C<sup>1</sup>, with an infrared to parallel converter (Jet-Eye), which you can order as M3080A Option #H05, or

an HP LaserJet 2100<sup>1</sup> with a built in infrared interface. You can also use the LaserJet with the Jet-Eye, but then you will also need a Centronics printer extension cable.

1. The exact printer model listed here may no longer be current. Please check with your Philips representative for currently available, compatible printers.

## Connecting a Printer

Make sure that the infra-red printer port is at least 50cm (20 inches) from any SpO<sub>2</sub> transducer while you are printing, to avoid disturbing the SpO<sub>2</sub> measurement.

If you are connected to a Central Monitor or have an M3 Print Server, you can also use the HP LaserJet 2100 as a network printer or use a DeskJet 610C attached locally to the Print Server PC.

**Step 1.** Press the **Setup** key.

**Step 2.** Move the highlight to **Printer**.

**Step 3.** Press on the strip to select the Printer window.

**Step 4.** Move the highlight to **Printer**.

**Step 5.** Press on the strip.

**Step 6.** Select the appropriate setting:

None	If there is no printer. All printing operations are disabled.
Local	To enable a local printer.
Remote 1	To enable a printer connected through the network. <sup>a</sup>
Remote 2	To enable a printer connected through the network. <sup>a</sup>
Remote 3	To enable a printer connected through the network. <sup>a</sup>

- a. If any Remote printers are available, there will always be three printers shown irrespective of the actual number of printers connected via the Network. The correlation to actual printers on the network is configured at the M3 Print Server, if present. If a Central Monitor is connected, the central printer will be used as default.

## Connecting a Local Printer

---

### Warning

---

The printer and any other non-medical equipment (such as the infrared to parallel converter) are not allowed to be used within the patient vicinity (1.5m/4.9 ft.).

---

If you are using an infrared to parallel converter

**Step 1.** Connect the parallel port to the printer.

**Step 2.** Position the converter

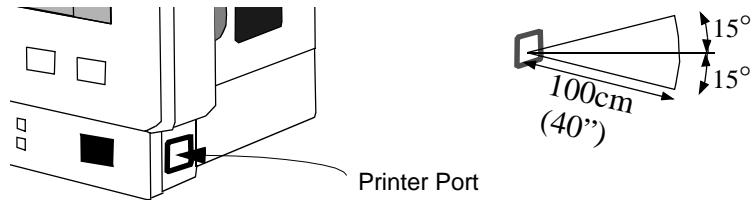

- within 100cm (40") of the infra-red port
- within 15° of the line perpendicular to the plane of the port

You can use the JetEye holder (which comes with the M3080A Option #H05) for the optimal position the JetEye. See the Service Manual for information on mounting this holder

Read the documentation supplied with the JetEye for information on the JetEye power supply, and the correct connection.

If you are using a printer with a built-in infrared port,

- Position the printer within 100cm (40") of either infra-red port
- within 15° of the line perpendicular to the plane of the port

## Connecting a Remote Printer

For remote printing, the monitor must be connected to the patient monitoring wired network (with wireless networks, central printing is not available). The network cable is connected to the LAN socket on the back of the monitor.

---

### Warning

The monitor must be connected to the dedicated patient monitoring network only. The special network cables supplied by Philips Medical Systems for this purpose must be used (see M3 Print Server Installation and Service Guide or Information Center Installation Guide for details).

---

## **Trouble-shooting the Printer Connection**

**If you cannot find the print softkeys, or if the Print Screen SmartKey is inactive:**

Make sure that printer is configured (see “Press the Setup key.” on page 336).

**If you do not get a printout:**

- Make sure that the printer is connected to the JetEye
- Make sure that the JetEye is positioned properly at the side of the monitor (see “Connecting a Local Printer” on page 337),
- Make sure that both the JetEye and the printer are switched on.

**If your printout is too big for the page:**

- Make sure both the printer and the JetEye are switched on, and print again.  
This happens if the JetEye was switched on but the printer was switched off when you started printing.

**If a “Remote Printer not available” message appears on the screen:**

- Check that the monitor is connected to the network, if yes,
- Contact the M3 Print Server system administrator (if you are printing on a Print Server).
- Check that the central printer is switched on and not in an error condition.

**If the printout does not appear at the central printer but there is no error message at the monitor**



- Check that the central printer is switched on and not in an error condition. If yes, and you are printing on a Print Server,
- Contact the Information Center system administrator

## Connecting a Local Recorder

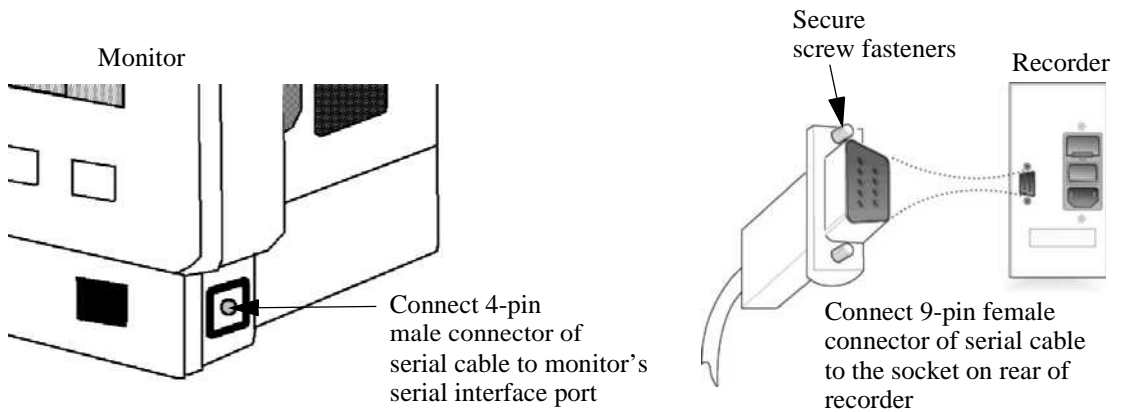
You can connect a standalone strip chart recorder (GSI Lumonics XE-50p) to your monitor via the serial recorder interface, available as option #J16. A dedicated cable is supplied with the recorder. Details of how to set up, use and care for the recorder are given in the *Operator's Manual* that accompanies it.



**Step 1.** Connect the 9-pin female connector of the serial interface cable to the socket on the rear of the recorder. Ensure that the DB9 connector is firmly fitted to the socket and secure it by tightening the screw fasteners.

**Step 2.** Connect the 4-pin male connector of the serial interface cable to the serial interface port on the monitor marked with the   symbols.

Order the Roller Stand (M3080A Option #A30) or the Wall Mount (M3080A Option #A31) for a dedicated mounting solution for your recorder. See the Service Guide for information on mounting the recorder.

The following recordings are supported:

- Start/Stop real-time (see “Recording Strips Locally” on page 46)
- Start/Extend delayed (“Recording Strips Locally” on page 46)
- Alarm (see “Alarm Recording” on page 60)

## Connecting a Local Recorder

- Vital signs
- Trends and stored events (see “Printing and Recording the Trend Data” on page 273)

The recordings always show the first three displayed wave forms. The height of the wave channels is automatically adjusted according to the number of waves displayed:

Wave Channel	Number of Waves		
	3	2	1
Channel 1	2 cm	2 cm	4 cm
Channel 2	1 cm	2 cm	-
Channel 3	1 cm	-	-

Only Roman-8 characters are shown on the recorder. Monitor texts are sent to the local recorder, printer or Information Center in English for monitors marketed in some East European and Asiatic countries. Refer to the booklet “Translation Reference for M3/M4 Patient Monitor Texts” for a translation of the English text into the localized language.

---

## Fitting and Removing the Rubber Bezel Protector

For cleaning instructions, “Cleaning” on page 279.

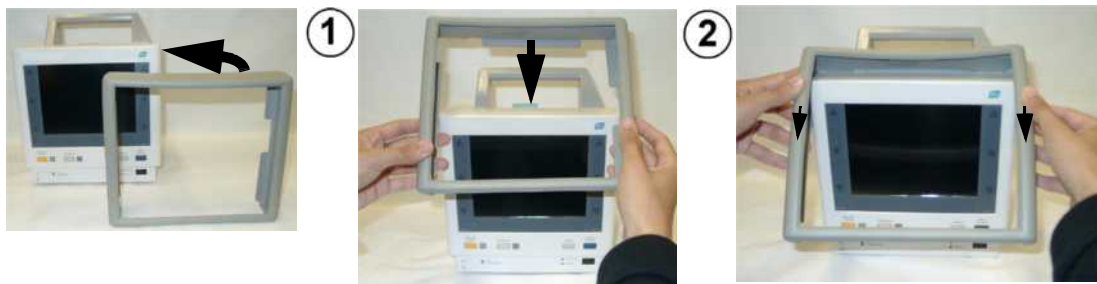

Fitting and Removing the Rubber Bezel Protector

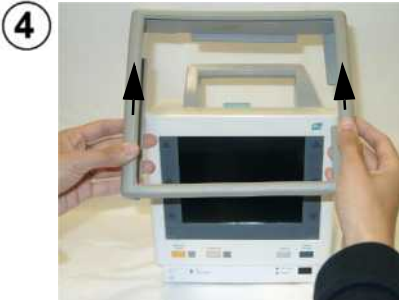



---

## Disposing of the Monitor, Measurement Server and Measurement Server Extension

---

### Warning

---

**To avoid contaminating or infecting personnel, the service environment or other equipment, make sure the equipment has been appropriately disinfected and decontaminated before disposal.**

---

---

The battery can be easily removed (see “Changing the Battery” on page 312), and can be returned, free of charge, to the worldwide-recycling program run by the battery manufacturer (contact your local supplier).

The Monitor and Measurement Server can be disassembled (see the disassembly instructions in the Service Guide).

- There is no metal molded into the plastic case, and no metal sprays on the plastic.  
All plastic parts with a weight greater than 10g (0.35 ounces) are marked with the ISO code for identification.  
All labelling on the product has been done by laser printing, so no separation is necessary before recycling.
- The sheet metal card cage uses only one kind of steel.
- The handle is a 2 compound molding, separable by the application of force.
- The screen has a touch resistor laminate, separable by the application of force.
- User documentation is wire-o bound. The binding is separable by the application of force.  
Service documentation is perfect bound, and can be recycled as is.  
No heavy metals were used in printing the documentation.
- The cardboard and foam used in packaging are 100% recyclable.  
No heavy metals were used in printing the packaging.



# Configuration

This chapter provides information on how to configure the M3 and M4 patient monitors to suit the specific needs of your unit.

- Configuration Features . . . . . 348
- Extra Configuration for the Bed to Bed Overview . . . . . 353
- Extra Configuration for the ECG Measurement . . . . . 354
- Extra Configuration for the RESP Measurement . . . . . 359
- Extra Configuration for the SpO<sub>2</sub> Measurement . . . . . 359
- Extra Configuration for the NBP Measurement . . . . . 361
- Extra Configuration for the PRESS Measurement . . . . . 362
- Extra Configuration for the TEMP Measurement . . . . . 364
- Extra Configuration for the DTEMP Measurement . . . . . 364
- Extra Configuration for the CO<sub>2</sub> Measurement . . . . . 365
- Extra Configuration for Transferring A Patient . . . . . 366
- Configuring the Alarms . . . . . 369
- Extra Configuration for the Events . . . . . 373
- Extra Configuration for the Monitor . . . . . 374
- List of Configurable Settings . . . . . 380

This chapter describes how Configuration Mode works, how to access Configuration Mode, how to change settings in Configuration Mode, how to leave Configuration Mode, and how to save configurations in Quicksets.

## **Who this Chapter is For**

This chapter is intended for hospital Biomedical Engineers or Philips Service and Clinical Specialist personnel who are about to perform the off-line configuration procedures for the M3 or M4. It is also intended for Nurses and Clinicians who need to customize the instrument's configuration settings to their requirements.

## **What you can Configure**

Most of the information displayed on the monitor screen of the monitor can be configured, for example, parameter settings, alarm limits, patient data, tone modulation and even the color and brightness of the main display.

By selecting Configuration Mode additional settings are available to the user which are not visible in Monitoring Mode.

When the monitor is put into Configuration Mode, the current *Active Settings* selected in Monitoring Mode are maintained. These settings can then be stored in the configuration of the monitor and re-selected at any time.

You can also select whether the Active Settings should be maintained after the monitor has been switched off for more than 60 seconds. To do this, the general setting “AutoDefault” must be configured to **No**. If the setting is set to **Yes**, the system will automatically select the current Quick Set when it is switched back on and the Active Settings will be lost.

A software tool (the M3086A Support Tool) is available to clone configurations, to print the configuration of a monitor, to enter the monitor label and hospital name, or to perform software upgrades.

## How do I get into Configuration Mode?

*Note*—The configuration of the System requires the use of a password. This is to prevent the configuration being altered either accidentally or by unauthorized personnel.

To get into Configuration Mode, do the following:

Step	Action	Comment
1	Switch on the monitor.	
2	Press the <b>Setup</b> button on the front panel of the monitor.	The Setup selection window is displayed.
3	Select <b>Operating Modes</b>	The Operating Mode task window displays four choices. The one currently running is marked with a *.
4	Select <b>Config</b>	A set of keys will open at the bottom of the screen for the password.
5	Enter the password (the password is noted in the Service Guide). Select <b>OK</b>	Use the keys labelled 1 to 5. If the password is correct, <b>Config</b> will be marked with a * in the Operating Modes task window.

Step	Action	Comment
6	Select <b>Exit</b> until the Operating Mode task window disappears from the screen or,  Press <b>Main Screen</b> on the front panel of the monitor.	

When Configuration Mode is activated, the following message appears at the top of the screen:

- **Config** (which alternates with)
- to exit: cycle power

Note

When you have finished adjusting the settings and you want to make your changes permanent, they must be stored in one of the available QuickSets (see “Saving current settings to a Quick Set” on page 351).

If you exit the configuration mode before storing your changed settings in a QuickSet, the changes will be lost.

### How do I leave Configuration Mode?

Before leaving Configuration Mode, make sure you have stored all the active settings.

To leave Configuration Mode you can either:

- Switch the monitor off and back on again,  
OR
- Press **Setup** on the front panel of the monitor.
- Select **Operating Modes**.
- Select **Monitoring**.
- Select **Confirm**.

*Note*—You do not need a password to return to Monitoring Mode.

---

## Configuration Features

### How does Configuration Mode Work?

The Configuration Mode consists of three main elements; Quick Sets, General Settings and Factory Default Sets.

#### Quick Sets

The settings contained within Configuration Mode apply to the M3046A Monitor, the M3001A Measurement Server and the M3015/16 Measurement Server Extensions. These settings are divided up into four specific configuration groups called Quick Sets.

A QuickSet is a group of settings which has been defined and named in the hospital. If you are familiar with the IntelliVue family of patient monitors, QuickSets are broadly equivalent to Profiles. Four different QuickSets can be defined to match four typical monitoring situations on your unit. To create a QuickSet you can use either the current settings which you have on the monitor or you can start from the most appropriate of the factory default sets and make your own adjustments until all settings meet your requirements. A listing of the settings in the factory default sets can be found in “Quick Set Configuration List for the Measurements” on page 380.

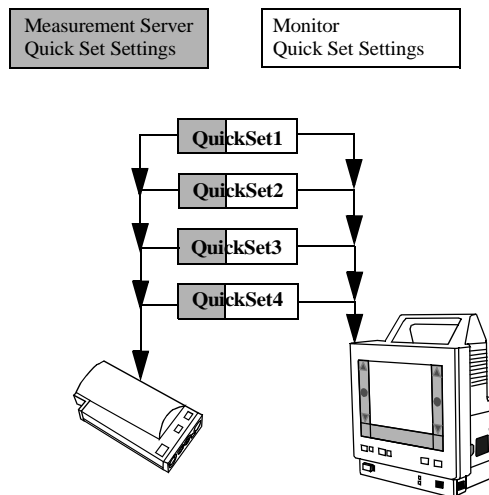

When you receive your monitor, the Quick Sets are pre-configured to represent four distinct patient categories:

- QuickSet 1 = **Adult ICU**
- QuickSet 2 = **Adult OR**
- QuickSet 3 = **Pediatric**
- QuickSet 4 = **Neonatal**

The settings contained within the Quick Sets can be adjusted and saved by the user in Configuration Mode. If required, the names of the Quick Sets can also be changed, for example, the name “QuickSet1” could be changed to “ICU 1”.

---

Note

In addition, the Configuration Mode has a fifth Quick Set available for saving temporary information. This Quick Set is intended as a support function to allow the user to make temporary adjustments to the system settings and save them, without affecting the settings of the four defined Quick Sets.

The name of the fifth Quick Set cannot be changed. The information is marked with the date and the time the settings were saved in the system.

---

**General Settings**

The monitor has a number of general settings that define items such as the Quick Set names, Automatic Default and Printer Type. These settings are independent of, and unaffected by, the configuration of the Quick Sets. You only need to adjust them once, they do not need to be readjusted for each QuickSet.

**Factory Default Sets**

The monitor is shipped to you with four pre-configured Factory Default Sets that are based on patient category and environment.

To begin with, the settings for the four Quick Sets are copied directly from the Factory Default Values. Unlike the Quick Sets, the Factory Default Values cannot be adjusted, they are permanently configured to represent the four main patient categories:

- Default Set A (Adult ICU)
- Default Set B (Adult OR)

## Configuration Features

- Default Set C (Pediatric)
- Default Set D (Neonatal)

The Factory Default Sets are intended to help the user re-set the monitor back to its original configuration. If for example, the settings contained within QuickSet 1 have been adjusted so much that the original settings have been totally lost, the user can re-capture the original settings by selecting the Default Set A. QuickSet 1 can then be stored with the original settings.

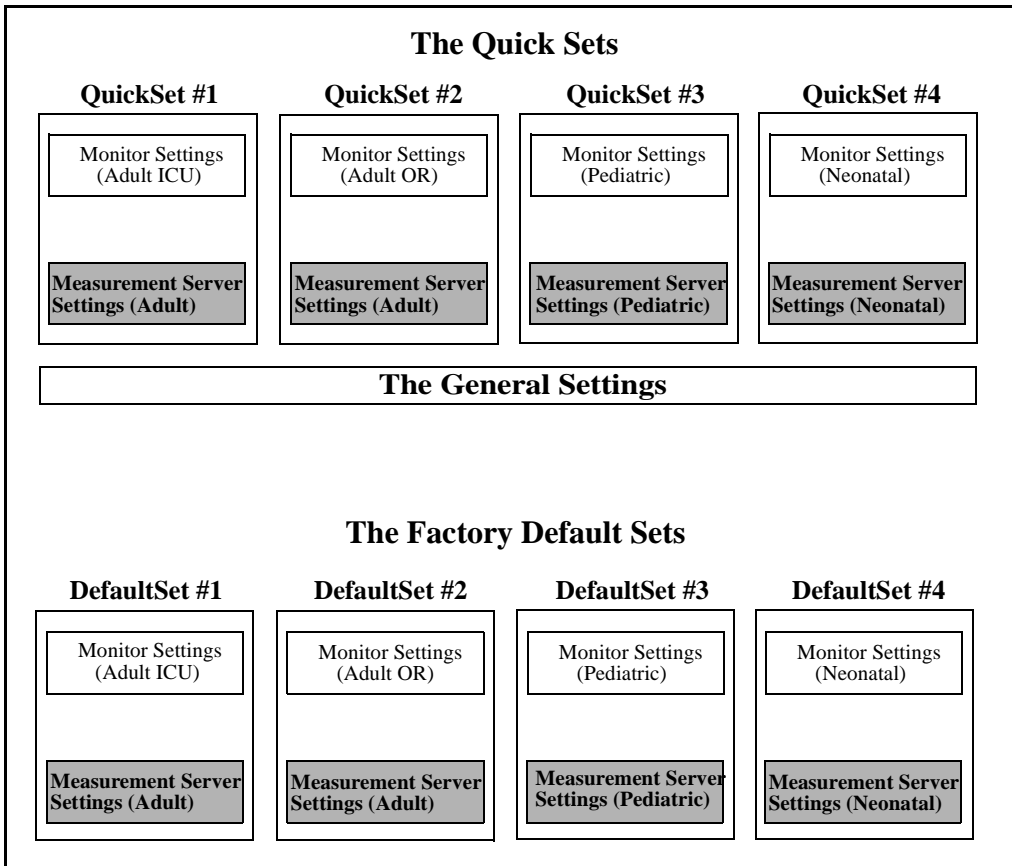



## How do I Configure a Quick Set?

You can adjust the settings in a Quick Set in both Monitoring Mode and Configuration Mode when the Measurement Server and, if applicable, the Measurement Server Extension are connected. To view, adjust and store the *full* group of settings, you must be in Configuration Mode.

### Configuring the Monitor at installation

**Step 1.** Enter Configuration Mode (see above)

**Step 2.** Access the Quick Sets window:

- Press **Setup** on the front panel of the monitor and select QuickSets in the setup task window.
- OR
- Select the QuickSets SmartKey.
- OR
- Highlight the patient information area at the top left of the screen and press on the TouchStrip, then select **QuickSets**.

**Step 3.** Select the first Quick Set you wish to configure and then select **Confirm**.

*Note*—At this point, you can also give the Quick Set an appropriate name by selecting **Rename QuickSet** and using the alphabet keys. Then select **OK**.

**Step 4.** Exit the QuickSets window.

**Step 5.** Make adjustments to the settings:

- To adjust individual settings,
  - For measurements, highlight a numeric on the screen and press the TouchStrip to access the setup window,
  - OR
  - Press **Setup** on the front panel of the monitor and select the required setup window.
- To customize all monitor settings, follow the order in the table at the end of this guide.

**Step 6.** Go back to the Quick Set window (see above)

**Step 7.** Make sure that the correct Quick Set is selected and store the active settings by selecting **Confirm**.

**Step 8.** Now repeat this procedure for each Quick Set until you have the required settings for each patient category.

### Saving current settings to a Quick Set

**Step 1.** Enter Configuration Mode (see above).

**Step 2.** If you have not already adjusted the settings, or you wish to adjust the settings only available in Configuration Mode, do so now:

- For measurements, highlight a numeric on the screen and press the TouchStrip to access the setup window,
- OR

- Press **Setup** on the front panel of the monitor and select the required setup window.

**Step 3.** When you are satisfied that the active settings of the monitor are the way you want them to appear in the Quick Set, access the Quick Sets window:

- Press **Setup** on the front panel of the monitor and select QuickSets in the setup task window.

OR

- Select the QuickSets icon at the bottom of the screen.

OR

- Highlight the patient information area at the top left of the screen and press on the TouchStrip, then select **QuickSets**.

**Step 4.** Select the QuickSet you wish to use to store the Active Settings.

**Step 5.** Select **Store QuickSet**.

**Step 6.** Select **Confirm**.

*Note*—If the settings in a QuickSet are inconsistent in some way, the following message will appear on the display:

**The QuickSet (QuickSet name or number) is corrupt - check settings**

If this message appears, reload the Factory Default Settings.

### **How to rename a Quick Set**

**Step 1.** Access the Quick Sets task window.

**Step 2.** Select the QuickSet you wish to rename.

**Step 3.** Select **Rename QuickSet**.

**Step 4.** Enter the name you wish to use with the alphabet buttons.

**Step 5.** Select OK.

**Step 6.** Select **Confirm**.

### **How do I configure General Set- tings**

**Step 1.** Enter Configuration Mode (see above)

**Step 2.** Make adjustments to the settings:

- Press **Setup** on the front panel of the monitor and select the required setup window.

**Step 3.** Once you have made the adjustments to the settings, you can exit the setup window and then Configuration Mode, you do not need to confirm the adjustments.

*Note*—Unlike the QuickSets, the General Settings cannot be *automatically* reset to their original configuration. See “General Settings” on page 380 for a complete list of original General Settings.

---

## Extra Configuration for the Bed to Bed Overview

### Changing What Happens When Another Monitor in the Care Group has an Alarm

- Step 1.** If you are not already in the Setup menu, press the **Setup** key.  
**Step 2.** Move the highlight to **AutoWindow**.  
**Step 3.** Press on the strip.  
**Step 4.** Select the appropriate setting:

CareGrp	A window with a list of all the monitors in the Care Group is displayed automatically.
PatWin	A patient window for the remote monitor is displayed automatically.
Off	No window is displayed on alarm.

### Changing Whether the Care Group Status is Displayed

- Step 1.** If you are not already in the Setup menu, press the **Setup** key.  
**Step 2.** Move the highlight to **CareGrpStat**.  
**Step 3.** Press on the strip.  
**Step 4.** Select the appropriate setting:

On	The line with the status symbol for each monitor in the Care Group is shown at the top of the screen.
Off	The status is not displayed. If AutoWindow is also set to Off, a prompt message will be displayed if an alarm occurs in the Care Group.

## Extra Configuration for the ECG Measurement

### Selecting the Maximum Number of ECG Channels

In ECG setup (“Selecting the ECG Setup” on page 131):

**Step 1.** Select **Active Ch.** This defines which channels can be displayed for the ECG.

**Step 2.** Select the appropriate setting.

ECG 1	The wave for the ECG lead configured for Channel ECG 1 can be displayed.
ECG 1+2	The waves for the ECG leads configured for Channels ECG 1 and ECG 2 can be displayed.
ECG 1+2+3	The waves for the ECG leads configured for Channels ECG 1, ECG 2 and ECG 3 can be displayed.

### Selecting How ECG Filtering Changes during ESU

In ECG setup (see “Selecting the ECG Setup” on page 131):

**Step 1.** Select **AutoFilter**.

**Step 2.** Select the appropriate setting.

On	The ECG filtering is set automatically by the monitor if Electro-Surgery is detected.
Off	The ECG filtering stays with the user selection, even if Electro-Surgery is detected.

### Selecting the ECG Wave Default Size

You can set the size of all ECG waves to a default size that is applied when the monitor is switched on.

**Step 1.** In the Setup ECG menu, select **DefaultSize**.

**Step 2.** Select the required default adjustment factor from the line of pop-up keys:

- **x0.5** to halve the wave size
- **x1** to display the zoom without zoom

- **x2** to double the wave size
- **x4** to multiply the wave size by four
- **Auto** to optimize the wave size in all channels

## Selecting the Color for the ECG

In ECG setup (see “Selecting the ECG Setup” on page 131):

**Step 1.** Select **Color**. This defines the color for the ECG wave and the Heart Rate numeric, when this is derived from the ECG,.

**Step 2.** Select the color.

If the Heart Rate is derived from the SpO<sub>2</sub> or the invasive pressure, it will have the color for SpO<sub>2</sub> or the invasive pressure.

## Setting the Tachycardia Alarm Limit

There are two parts to the tachycardia alarm limit.

- **Δ ExtrTachy**, which is how many bpm above the ECG high alarm limit the tachycardia limit is.
- **Tachy Clamp** is the value above which the tachycardia alarm limit becomes the same as the ECG high alarm.

The tachycardia limit is set to the lower value of either Tachy Clamp or the Δ ExtrTachy added to the ECG High Limit.

For example, if you set **Δ ExtrTachy** to 10 and **Tachy Clamp** to 200, and the ECG High Limit is set to 185, then the tachycardia limit is 195 (that is, Δ ExtrTachy added to the ECG High Limit).

If, however, the ECG High Limit is set at 195, then the tachycardia alarm limit is 200 (that is, Tachy Clamp).

In ECG setup (see “Selecting the ECG Setup” on page 131):

**Step 1.** Select **Δ ExtrTachy**.

**Step 2.** Select the appropriate setting for the maximum difference above the ECG High Limit.

**Step 3.** Select **Tachy Clamp**.

**Step 4.** Select the appropriate setting for the maximum tachycardia limit.

## Setting the Bradycardia Alarm Limit

There are two parts to the bradycardia alarm limit.

- **Δ ExtrBrady**, which is how many bpm below the ECG low alarm limit the bradycardia limit is.
- **Brady Clamp** is the absolute lowest value for the bradycardia alarm limit.

## Extra Configuration for the ECG Measurement

The bradycardia limit is set to the lower value of either **Brady Clamp** or the  $\Delta$  **ExtrBrady** subtracted from the ECG Low Limit.

For example, if you set  $\Delta$  **ExtrBrady** to 10 and **Brady Clamp** to 40, and the ECG Low Limit is set to 55, then the bradycardia limit is 45 (that is,  $\Delta$  **ExtrBrady** subtracted from the ECG Low Limit).

If, however, the ECG Low Limit is set at 45, then the bradycardia alarm limit is 40 (that is, **Brady Clamp**).

In ECG setup (see “Selecting the ECG Setup” on page 131):

**Step 1.** Select  $\Delta$  **ExtrBrady**.

**Step 2.** Select the appropriate setting for the minimum difference below the ECG Low Limit.

**Step 3.** Select **Brady Clamp**.

**Step 4.** Select the appropriate setting for the maximum bradycardia limit.

## Setting the Lead Fallback mode

The lead fallback mode determines whether the monitor will automatically switch another lead into channel 1 if the lead in channel 1 becomes unavailable

In ECG setup see (“Selecting the ECG Setup” on page 131):

**Step 1.** Select **Fallback**.

**Step 2.** Select the appropriate setting.

On	The lead from channel 2 or 3 will be switched to channel 1 if channel 1 is in INOP for 10 seconds (and channel 2 or 3 is not in INOP).
Off	No lead switching is done when channel 1 is in INOP.

In EASI mode, fallback is always on.

## Displaying “All ECG ALARMS OFF” INOP

The “All ECG ALARMS OFF” INOP is displayed when the ECG alarms are switched off or when the HR source is not ECG. You can decide whether the INOP should be displayed or not.

In the ECG Setup (see “Selecting the ECG Setup” on page 131):

**Step 1.** Select **ALL ECG IN**.

**Step 2.** Select the appropriate setting.

On	The “All ECG ALARMS OFF” INOP is displayed when the ECG alarms are switched off or when the HR source is not ECG.
Off	No INOP is displayed.

---

## Extra Configuration for the Arrhythmia Analysis

### Setting Time-out Periods for Arrhythmia Yellow Alarms

In Arrhythmia Setup (see “Selecting the Arrhythmia Setup” on page 159):

**Step 1.** Select **TimeOut 1st**. This defines the length of time (timeout period) which certain yellow arrhythmia alarms are inhibited after they have been announced once. This time applies to all alarms above Vent Bigeminy in the alarm chain (see “Alarm Priorities and Timeout Periods” on page 154 for more information).

**Step 2.** Select the appropriate setting for the timeout period.

**Step 3.** Select **TimeOut 2nd**. This time applies to all alarms below Vent Bigeminy in the alarm chain.

**Step 4.** Select the appropriate setting for the timeout period.

### Setting the Pause Alarm Threshold

In Arrhythmia Setup (see “Selecting the Arrhythmia Setup” on page 159):

**Step 1.** Select **PauseThresh** to enter a list of choices for setting the pause alarm threshold.

**Step 2.** Select the time you wish to set from the list.

- 1.50, 1.75, 2.00, 2.25, and 2.50 sec

### Displaying an Arrhythmia Off Message

In Arrhythmia Setup (see “Selecting the Arrhythmia Setup” on page 159):

**Step 1.** Select **Arrhy.OffMsg**. This defines whether an **Arrhythmia OFF** message is displayed in the first ECG channel when Arrhythmia is switched off.

**Step 2.** Select the appropriate setting, **Yes** or **No**.

## Displaying “SOME ECG ALARMS OFF” INOP

The “SOME ECG ALARMS OFF” INOP is displayed when additional alarms are switched off compared to the current QuickSet. You can decide whether the INOP should be displayed or not

In Arrhythmia Setup (see “Selecting the Arrhythmia Setup” on page 159):

**Step 1.** Select **SOME ECG IN**.

**Step 2.** Select the appropriate setting.

On	The “SOME ECG ALARMS OFF” INOP is displayed when additional alarms are switched off compared to the current QuickSet.
Off	No INOP is displayed.

---

## Extra Configuration for the ST Measurement

### Adjusting the ISO, J and ST Points

In ST Setup (see “Selecting the ST Setup” on page 172):

**Step 1.** Select **ISO Point**.

**Step 2.** Adjust the position of the ISO point using the arrow keys.

**Step 3.** Select the J Point using the **Select Point** key.

**Step 4.** Adjust the position of the J point using the arrow keys.

**Step 5.** Select the ST Measurement Point using the **Select Point** key.

**Step 6.** Select the position using the **J+60** and **J+80** keys, if necessary.



---

## Extra Configuration for the RESP Measurement

### Selecting the Color for the RESP

In RESP setup (see “Selecting the Respiration Setup” on page 181):

- Step 1.** Select **Color**. This defines the color for the RESP wave and the Respiration Rate numeric.
- Step 2.** Select the color.

---

## Extra Configuration for the SpO<sub>2</sub> Measurement

### Changing the Averaging Time for SpO<sub>2</sub>

In SpO<sub>2</sub> setup (see “Selecting the SpO<sub>2</sub> Setup” on page 229):

- Step 1.** Select **Average**. This defines the length of time for which the measurement is averaged to get the SpO<sub>2</sub> measurement.  
A longer averaging time gives a more stable measurement.  
A shorter averaging time gives a faster reaction to the changes in the patient’s arterial oxygen saturation.
- Step 2.** Select the appropriate setting.

---

#### Caution

The averaging time (see “Changing the Averaging Time for SpO<sub>2</sub>” on page 359) also has an influence on how long before the low alarm is triggered.

---

### Changing the Time Elapsed Before the Low Alarm

In SpO<sub>2</sub> setup (see “Selecting the SpO<sub>2</sub> Setup” on page 229):

- Step 1.** Select **Low Al. Del.** This defines the length of time the SpO<sub>2</sub> measurement can be below the low alarm limit before an alarm occurs.
- Step 2.** Select the appropriate setting.

### Changing the Time Elapsed Before the High Alarm

In SpO<sub>2</sub> setup (see “Selecting the SpO<sub>2</sub> Setup” on page 229):

- Step 1.** Select **High Al. Del.** This defines the length of time the SpO<sub>2</sub> measurement can be above the high alarm limit before an alarm occurs.
- Step 2.** Select the delay time from the choices:
  - 0 sec to 30 sec

### Selecting the Color for SpO<sub>2</sub>

In SpO<sub>2</sub> setup (see “Selecting the SpO<sub>2</sub> Setup” on page 229):

- Step 1.** Select **Color**. This defines the color for the PLETH wave and the SpO<sub>2</sub> numeric.
- Step 2.** Select the color.

### Selecting INOP Suppression during NBP Measurements

In SpO<sub>2</sub> setup (see “Selecting the SpO<sub>2</sub> Setup” on page 229):

- Step 1.** Select **NBP AlSuppr**. This defines whether to suppress INOPS generated during an NBP measurement on the same limb.
- Step 2.** Select the appropriate setting.

On	SpO <sub>2</sub> INOPs generated during an NBP measurement on the same limb will be suppressed.
Off	SpO <sub>2</sub> INOPs generated during an NBP measurement on the same limb will not be suppressed.

### Setting the Desaturation Alarm Delay

In SpO<sub>2</sub> setup (see “Selecting the SpO<sub>2</sub> Setup” on page 229):

- Step 1.** Select **Desat Delay**. to enter choices for delay times for the desaturation alarm.
- Step 2.** Select the delay time from the choices:
  - 0 sec to 30 sec

---

## Extra Configuration for the NBP Measurement

### Selecting the NBP Unit

In NBP setup (see “Selecting the NBP Setup” on page 197):

- Step 1.** Select **Unit** .  
**Step 2.** Select either **mmHg** or **kPa** .

### Selecting the Reference for the Measurement Method

In NBP setup (see “Selecting the NBP Setup” on page 197):

- Step 1.** Select **Reference** .  
**Step 2.** Select **Auscult.** or **Invasive** .

### Selecting the Color for the NBP

In NBP setup (see “Selecting the NBP Setup” on page 197):

- Step 1.** Select **Color** . This defines the color for the NBP numeric.  
**Step 2.** Select the color.

### Switch on a Beep at the end of the Measurement

In NBP setup (see “Selecting the NBP Setup” on page 197):

- Step 1.** Select **Done Tone** . This selects whether the monitor indicates that the NBP measurement has finished or not.  
**Step 2.** Select the appropriate setting.

On	The monitor will beep when the measurement has finished
Off	The monitor will not beep when the measurement has finished

### Selecting Clock-synchronized Start Time

In NBP setup (see “Selecting the NBP Setup” on page 197):

## Extra Configuration for the PRESS Measurement

**Step 1.** Select **Start Time**. This selects whether NBP measurement start times are synchronized with the clock.

**Step 2.** Select the appropriate setting.

Synchron	The monitor will start measurements synchronized with the clock.
NotSynch	The monitor will not synchronize measurement start times

### Selecting the Pressure for Venipuncture Mode

In NBP setup (see “Selecting the NBP Setup” on page 197):

**Step 1.** Select **VP Pressure**. This defines the pressure to which the cuff will be inflated in Venipuncture mode.

**Step 2.** Select the required pressure from the list.

---

## Extra Configuration for the PRESS Measurement

The settings are saved separately for each pressure label. If you want to configure all of the pressure labels, you will need to repeat the configuration for each label.

### Setting Up the PRESS Filter

In the pressure setup (see “Selecting the Pressure Setup” on page 209):

**Step 1.** Select **Filter** to set the bandwidth of the filter.

**Step 2.** Select the appropriate setting for the bandwidth.

12Hz	This bandwidth gives a more accurate value for the pressures.
40Hz	This bandwidth gives more detailed wave for analysis for the pressures.

### Setting Up to Measure Mean Pressure Only

In the pressure setup (see “Selecting the Pressure Setup” on page 209):

**Step 1.** Select **Mean Only**.

**Step 2.** Select the appropriate setting.

Yes	The pressure measures the mean value only, even if the pressure is pulsatile.
No	The pressure measures mean, systolic and diastolic if the pressure is pulsatile.

### Enabling PRESS Transducer Calibration

In the pressure setup (see “Selecting the Pressure Setup” on page 209):

**Step 1.** Select **Mercury Cal.**

**Step 2.** Select the appropriate setting.

Yes	Entering calibration factors, or doing calibrations is possible.
No	Entering calibration factors, or doing calibrations is not possible.

### Non-Physio- logical Arti- fact Suppression

In the pressure setup (see “Selecting the Pressure Setup” on page 209):

**Step 1.** Select **ArtifSuppr.**

**Step 2.** Select the maximum suppression time between a non-physiological artifact signal and the associated alert (30, 60, or 90 seconds), or select **Off** to turn off artifact suppression.

### Selecting the Unit

In the pressure setup (see “Selecting the Pressure Setup” on page 209):

**Step 1.** Select **Unit.**

**Step 2.** Select either **mmHg** or **kPa**.

### Selecting the Color for the Pres- sure

In the pressure setup (see “Selecting the Pressure Setup” on page 209):

**Step 1.** Select **Color.** This defines the color for the pressure wave and the numeric.

**Step 2.** Select the color.

## Extra Configuration for the TEMP Measurement

The settings are saved separately for each temperature label. If you want to configure all of the temperature labels, you will need to repeat the configuration for each label.

### Selecting the Unit for the Temperature Measurement

In TEMP setup (see “Selecting the TEMP Setup” on page 239):

**Step 1.** Select **Unit**.

**Step 2.** Select the appropriate setting.

°C	The temperature will be shown in degrees Centigrade.
°F	The temperature will be shown in degrees Fahrenheit.

### Selecting the Color for TEMP

In TEMP setup (see “Selecting the TEMP Setup” on page 239):

**Step 1.** Select **Color**. This defines the color for the TEMP numeric.

**Step 2.** Select the color.

---

## Extra Configuration for the $\Delta$ TEMP Measurement

### Selecting the Unit for the $\Delta$ Temperature Measurement

In  $\Delta$ TEMP setup (see “Selecting the  $\Delta$ TEMP Setup” on page 240):

**Step 1.** Select **Unit**.

**Step 2.** Select the appropriate setting.

°C	The temperature difference will be shown in degrees Centigrade.
°F	The temperature difference will be shown in degrees Fahrenheit.

**Selecting the Color for ΔTEMP**

In ΔTEMP setup (see “Selecting the D TEMP Setup” on page 240):

- Step 1.** Select **Color** . This defines the color for the ΔTEMP numeric.
- Step 2.** Select the color.

**Extra Configuration for the CO<sub>2</sub> Measurement**

**Selecting the Unit for the CO<sub>2</sub> Measurement**

In CO<sub>2</sub> setup (see “Selecting the CO<sub>2</sub> Setup” on page 249):

- Step 1.** Select **Unit** .
- Step 2.** Select either mmHg or kPa.

**Selecting the Color for CO<sub>2</sub>**

In CO<sub>2</sub> setup (see “Selecting the CO<sub>2</sub> Setup” on page 249):

- Step 1.** Select **Color** . This defines the color for the CO<sub>2</sub> wave and numeric.
- Step 2.** Select the color.

**Selecting Sampling Method for EtCO<sub>2</sub> (and ImCO<sub>2</sub> for the Side-stream Method)**

In CO<sub>2</sub> setup (see “Selecting the CO<sub>2</sub> Setup” on page 249):

- Step 1.** Select **Max Hold** . If **Max Hold** is on, the largest measured value out of the selected time period is displayed.
- Step 2.** Select the time period

off	The breath to breath value is displayed
10 sec	The largest measured value from the last 10 seconds is displayed.
20 sec	The largest measured value from the last 20 seconds is displayed.

**Selecting ImCO<sub>2</sub> On/Off**

In CO<sub>2</sub> setup (see “Selecting the CO<sub>2</sub> Setup” on page 249):

- Step 1.** Select **ImCO<sub>2</sub>** .
- Step 2.** Select **On** or **Off** to switch the ImCO<sub>2</sub> measurement on or off.

## Selecting Humidity Correction Method for CO<sub>2</sub>

In CO<sub>2</sub> setup (see “Selecting the CO<sub>2</sub> Setup” on page 249):

**Step 1.** Select **Humidity Correction**. This defines the method used to correct the measured EtCO<sub>2</sub> value and wave for humidity.

**Step 2.** Select the correction method:

BTPS	Correction is made according to the BTPS (Body Temperature Pressure Saturated) method. In this mode the CO <sub>2</sub> readings correspond to the partial pressure of CO <sub>2</sub> in humidified (saturated) gases at 37°C. The BTPS corrected values correspond to the alveolar partial pressure of CO <sub>2</sub> .
STPD	Correction is made according to the STPD (Standard Temperature Pressure Dry) method. In this mode the CO <sub>2</sub> readings correspond to the partial pressure of CO <sub>2</sub> in dry gases at 25°C.

---

Note

The CO<sub>2</sub> readings in BTPS mode are about 6 to 12% lower than the readings in STPD mode.

---

---

## Extra Configuration for Transferring A Patient

### Changing What Happens Automatically

You can set how the monitor treats patient data when a Measurement Server with different patient data is attached to a monitor.

**Step 1.** In configuration mode, select the Patient Identification menu (see “Selecting the Patient Identification Menu” on page 94).

**Step 2.** Select the **PatientSelDef**.



**Step 3.** Select the appropriate setting:

Cont MsrServer	The patient data in the Measurement Server is always used.
Cont Mon	The patient data in the monitor is always used.
New Pat	All patient data is ignored, and a new patient is always admitted.
Ask User	The patient has to be selected (as described in “Attaching to a New M3046A Monitor...” on page 100).

## Changing Which Settings are Used

You can also set how the monitor handles the measurement settings when a Measurement Server with different patient data is attached to a monitor. Patient data is not affected by this setting.

**Step 1.** In configuration mode, select the Patient Identification menu (see “Selecting the Patient Identification Menu” on page 94).

**Step 2.** Select the **ResetAlways**.

**Step 3.** Select the appropriate setting:

Yes	The measurement settings are reset to the current default setting (see “Recalling a QuickSet” on page 48).
No	The existing measurement settings are used.

## Naming the Monitor

This relabels the monitor.

---

### **Warning**

---

**If your monitor is connected to an Information Center, you should not rename the monitor locally as this can result in you losing the connection to the Information Center.**

---

A software tool (the M3086A Support Tool) is available to clone configurations, to print the configuration of a monitor, to enter the monitor label and hospital name, or to perform software upgrades.

**Step 1.** If you are not already in the Setup menu, press the **Setup** key.

**Step 2.** Move the highlight to “**Admit. Discharge**”.

**Step 3.** Press on the strip.

**Step 4.** Highlight “**Monitor Lbl**”.

**Step 5.** Enter the new name for the monitor.

For each letter

- a. Highlight then press the softkey with the letter you want.  
Highlight then press the up/down-arrow softkey for lower case letters and numbers and symbols  
You can backspace through what you have typed using the back arrow(<).
- b. When you have finished entering the name, highlight then press **OK**.  
If you want to exit without changing anything, highlight then press **EX**.

**Step 6.** To finish renaming, press the Confirm softkey.

## Entering the Hospital Name

A software tool (the M3086A Support Tool) is available to clone configurations, to print the configuration of a monitor, to enter the monitor label and hospital name, or to perform software upgrades.

**Step 1.** If you are not already in the Setup menu, press the **Setup** key.

**Step 2.** Move the highlight to “**Admit. Discharge**”.

**Step 3.** Press on the strip.

**Step 4.** Highlight “**Hosp. Label**”.

**Step 5.** Enter the name of the hospital.

For each letter

- a. Highlight then press the softkey with the letter you want.  
Highlight then press the up/down-arrow softkey for lower case letters and numbers and symbols  
You can backspace through what you have typed using the back arrow(<).
- b. When you have finished entering the name, highlight then press **OK**.  
If you want to exit without changing anything, highlight then press **EX**.

**Step 6.** To finish renaming, press the Confirm softkey.

---

## Configuring the Alarms

### Selecting the Alarms Setup

You may select Alarms Setup only when in **CONFIG** mode (see “How do I get into Configuration Mode?” on page 346)

**Step 1.** Press the **Setup** key.

**Step 2.** Move the highlight to “**Alarms**”.

**Step 3.** Press on the TouchStrip.

When you are finished with the Alarms Setup, press the **Main Screen** key.

### Changing How Long Alarms Stay Suspended

In the Alarm setup (see “Selecting the Alarms Setup” on page 369):

**Step 1.** Select **Alarms susp.** This defines the period of time for which alarms are not announced.

**Step 2.** Select the appropriate setting:

1min	Announcing alarms restarts automatically after 1 minute.
2min	Announcing alarms restarts automatically after 2 minutes.
3min	Announcing alarms restarts automatically after 3 minutes.
Infinite	Announcing alarms must be restarted by the user (by pressing the <b>Suspend</b> key)

## Let User be Reminded of Suspended Alarms

In the Alarm setup (see “Selecting the Alarms Setup” on page 369):

- Step 1.** Select **SuspRemind**. This defines whether a prompt is issued when either all vital alarm parameters or their alarms are turned off individually or main alarms are not announced (Alarm suspend).
- Step 2.** Select the appropriate setting:

Off	No prompt is issued.
On	If alarms are suspended a prompt is issued every 3 minutes. Prompt text: <b>All vital parameters or parameter alarms are off.</b>

The following parameters are considered vital parameters in the above definition:

Heart Rate, Pulse of SpO<sub>2</sub>, Pulse of InvPress, Resp, AWRR, InvPress, SpO<sub>2</sub>, and EtCO<sub>2</sub>.

## Changing How Alarms Behave Until Silenced

In the Alarm setup (see “Selecting the Alarms Setup” on page 369):

- Step 1.** Select **AudLatching**. This selects for which alarms the audible indicators will continue even when the original alarm condition no longer exists, until the **Silence/Reset** key is pressed.
- Step 2.** Select the appropriate setting
- Step 3.** Select **VisLatching**. This selects for which alarms the visual indicators will continue even when the original alarm condition no longer exists, until the **Silence/Reset** key is pressed.
- Step 4.** Select the appropriate setting:

R & Y	Both red and yellow alarm indicators are latching.
R	Only red alarm indicators are latching.
Off	All indicators stop when the original alarm condition no longer exists (non-latching). Use this if you do not need to acknowledge every alarm.

See the tables in “Dealing with Alarms” on page 54 for further details on the alarm behaviors for parameter and arrhythmia alarms.

## Changing the Alarm Reminder Behavior

In the Alarm setup (see “Selecting the Alarms Setup” on page 369):

- Step 1.** Select **Remind**. This defines how the monitor reminds the user about alarm conditions which still exist, after the **Silence/Reset** key has been pressed.
- Step 2.** Select the appropriate setting:

On	A reminder will be given for 6 seconds at the interval configured (see “Changing the Alarm Reminder Time” on page 371), as long as the alarm condition still exists
ReAlarm	If the alarm condition still exists after the configured interval (see “Changing the Alarm Reminder Time” on page 371), it is indicated again as if it were a new alarm.
Off	There is no indication of alarm conditions which have been acknowledged by pressing the <b>Silence/Reset</b> key.

## Changing the Alarm Reminder Time

In the Alarm setup (see “Selecting the Alarms Setup” on page 369):

- Step 1.** Select **Remind Time**. This defines how long the monitor waits before reminding the user about alarm conditions which still exist (see also “Changing the Alarm Reminder Behavior” on page 371).
- Step 2.** Select the appropriate setting

## Changing Whether Numerics Blink

In the Alarm setup (see “Selecting the Alarms Setup” on page 369):

- Step 1.** Select **Keep Blink**. This defines how a blinking numeric for a measurement that is in alarm, reacts when the alarms are suspended, or when the alarm for that measurement is switched off.
- Step 2.** Select the appropriate setting:

Yes	The numeric continues blinking as long as the measurement is in alarm, even if the <b>Suspend</b> key has been pressed, or the measurement alarm is switched off.
No	The numeric does not blink when the <b>Suspend</b> key is pressed, or the measurement alarm is switched off.

## Changing the Conditions for the Nurse Call Relay

In the Alarm setup (see “Selecting the Alarms Setup” on page 369):

**Step 1.** Select **Relay Sens.** This defines the conditions which will trigger the alarm relay (nurse call)

**Step 2.** Select the appropriate setting:

Red	The nurse call is activated for Red alarms only.
Red&Yell	The nurse call is activated for Red and Yellow alarms.
Red&Inop	The nurse call is activated for Red alarms and technical alarms (Inops).
R&Y&I	The nurse call is activated for Red and Yellow alarms and for technical alarms (Inops).

## Enable Automatic Main Alarms Suspended State

In the Alarm setup (see “Selecting the Alarms Setup” on page 369):

**Step 1.** Select **AutoSuspend.** This defines whether the Main Alarms Suspended state is activated automatically as soon as all vital alarm parameters or their alarms are turned off individually.

**Step 2.** Select the appropriate setting:

Off	<i>Main Alarms Suspended</i> state does not autoactivate.
On	<i>Main Alarms Suspended</i> state autoactivates, as soon as all vital alarm parameters or their alarms are turned off.

*Main Alarms Suspended* stops the monitor from indicating any alarms - including those for non-vital parameters, that might not have been turned off individually. Announcing alarms must be restarted by the user. The message “**Alarms Suspended**” is displayed at the upper right corner of the screen.

The user will be reminded of the **Main Alarms Suspended** state if the Suspend Reminder is turned ON.

## Selecting Where to Make Alarm Recordings

In the Alarm setup (see “Selecting the Alarms Setup” on page 369):

**Step 1.** Move the highlight to **Alarm Recordings**.

**Step 2.** Press on the strip

**Step 3.** Choose where to make the alarm recordings from the choices: **Local, Central, Both**.

If alarm recordings are configured to Local but the recorder is not connected or available, you will see the following message: “**No local alarm recording available**”. See also “Changing Which Alarms Trigger a Recording” on page 378.

---

## Extra Configuration for the Events

### Setting Up So that Events are Stored Automatically

**Step 1.** If you are not already in the Setup menu, press the **Setup** key.

**Step 2.** Move the highlight to “**Events**”.

**Step 3.** Press on the strip.

**Step 4.** Select the measurement.

**Step 5.** Choose the event trigger condition you want for the measurement:

Off	No Events are stored.
Red Only	An Event is stored every time the measurement goes into Red alarm. <i>Note</i> —Not all measurements have red alarms.
Red&Yell	An Event is stored every time the measurement goes into Red or Yellow alarm.

- The monitor can store up to 10 events automatically, if you have not stored any events manually.
- If you are storing events manually, the monitor will only keep the five most recent, automatically stored events.

---

## Extra Configuration for the Monitor

### Configuring the QRS Sound

- Step 1.** If you are not already in the Setup menu, press the **Setup** key.  
**Step 2.** Move the highlight to “**QRS Type**”.  
**Step 3.** Press on the strip.  
**Step 4.** Select the appropriate setting.

QRS Tone	The QRS sound is low pitched.
QRS Tick	The QRS sound is high pitched (normal in Japan).

- Step 5.** Move the highlight to “**QRS Low**”.  
**Step 6.** Press on the strip.  
**Step 7.** Select the appropriate setting.

Audible	The QRS sound cannot be switched off by the user.
Inaudible	The QRS sound can be switched off by the user.

- Step 8.** If you have finished configuring, exit the Setup menu.

### Configuring the Alarm Sound

- Step 1.** If you are not already in the Setup menu, press the **Setup** key.  
**Step 2.** Move the highlight to “**Alarm Volume**”.  
**Step 3.** Press on the strip.  
**Step 4.** Select the appropriate setting.

Audible	The alarm sound cannot be switched off by the user.
Inaudible	The alarm sound can be switched off by the user.

- Step 5.** If you have finished configuring, exit the Setup menu.



## Configuring the Prompt Volume

- Step 1.** If you are not already in the Setup menu, press the **Setup** key.  
**Step 2.** Move the highlight to “**Prompt Volume**”.  
**Step 3.** Press on the strip.  
**Step 4.** Select the appropriate setting.  
**Step 5.** If you have finished configuring, exit the Setup menu.

## Setting the Brightness for Battery Operation

- Step 1.** If you are not already in the Setup menu, press the **Setup** key.  
**Step 2.** Move the highlight to “**Tr. Brightn.**”.  
**Step 3.** Press on the strip.  
**Step 4.** Select the appropriate setting, for the brightness when the monitor is operating from the battery (10 is brightest, 1 is least bright, with Optimum the monitor will set the brightness automatically).

## Disabling the Measurement Server Keys

- Step 1.** If you are not already in the Setup menu, press the **Setup** key.  
**Step 2.** Move the highlight to “**Meas Serv Keys**”.  
**Step 3.** Press on the strip.  
**Step 4.** Select the appropriate setting.

Enabl.	The keys on the Measurement Server can be used.
Disabl.	The keys on the Measurement Server are ignored. Trying to use one of the keys will cause a prompt message on the screen of the monitor.

- Step 5.** If you have finished configuring, exit the Setup menu.

## Changing Whether the Units are Displayed

- Step 1.** If you are not already in the Setup menu, press the **Setup** key.  
**Step 2.** Select **Dspl. Units**. This defines whether the units are displayed or not.  
**Step 3.** Select the appropriate setting.

Yes	The units will be displayed.
No	The units will not be displayed.

*Note*—Units are never displayed for heart rate, pulse and respiration numerics.

## Changing ESU Filtering

- Step 1.** If you are not already in the Setup menu, press the **Setup** key.
- Step 2.** Move the highlight to “**Operating Room**”.
- Step 3.** Press on the strip.
- Step 4.** Select the appropriate setting.

No	The monitor operates without ESU filtering.
Yes	A filter for Electro-Surgery interference is switched on.

- Step 5.** If you have finished configuring, exit the Setup menu.

## Selecting Measurements for AutoLimits

- Step 1.** If you are not already in the Setup menu, press the **Setup** key.
- Step 2.** Move the highlight to “**AutoLimits**”.
- Step 3.** Press on the strip.
- Step 4.** Select All or an individual measurement
- Step 5.** Select the appropriate setting.

Enabled	Selected measurement(s) will be subject to AutoLimits when limits are set using the LimitsWide or LimitsNarrow SmartKey.
Disabled	Selected measurement(s) will not be subject to AutoLimits when limits are set using the LimitsWide or LimitsNarrow SmartKey.

## Configuring How to Exit from Windows

- Step 1.** If you are not already in the Setup menu, press the **Setup** key.
- Step 2.** Move the highlight to “**Exit Always**”.
- Step 3.** Press on the strip.
- Step 4.** Select the appropriate setting:

Yes	When the bottom left or right corner of the touchstrip is pressed you exit the active window without paging to further settings.
No	When the bottom left or right corner of the touchstrip is pressed you page to further settings and only exit the active window when no further settings are available.

## Changing Whether the Monitor Should be Connected to the Network

- Step 1.** If you are not already in the Setup menu, press the **Setup** key.  
**Step 2.** Move the highlight to **CentralMon**.  
**Step 3.** Press on the strip.  
**Step 4.** Select the appropriate setting:

Mandatory	The monitor should be connected to an Information Center. An INOP is displayed if no connection is available.
Optional	The monitor can be connected to an Information Center. An INOP is only displayed if the connection to the Information Center is lost. No INOP is displayed if no connection is found at power on.

## Changing Whether the Monitor can be Controlled Remotely

- Step 1.** If you are not already in the Setup menu, press the **Setup** key.  
**Step 2.** Move the highlight to **RemoteCtrls**.  
**Step 3.** Press on the strip.  
**Step 4.** Select the appropriate setting:

Enabled	The monitor allows control from the Information Center.
Disabled	The monitor does not allow control from the Information Center, and can only be controlled locally.

## Making the Altitude Setting

At Installation the altitude setting must be made.

- Step 1.** If you are not already in the Setup menu, press the **Setup** key.  
**Step 2.** Move the highlight to “**Altitude (m)**”.  
**Step 3.** Press on the strip.  
**Step 4.** Select the correct value for the altitude of the hospital.

## Changing Which Alarms Trigger a Recording

- Step 1.** If you are not already in the Setup menu, press the **Setup** key.  
**Step 2.** Move the highlight to **Alarm Recordings**.  
**Step 3.** Press on the strip.  
**Step 4.** Select a measurement.  
**Step 5.** Select the appropriate setting for that measurement:

Red&Yell	An alarm recording will be started for all red and yellow alarms.
Red Only	An alarm recording will only be started for red alarms.
Off	No alarm recordings will be made.

## Changing Whether a Printer is to be attached

- Step 1.** If you are not already in the Setup menu, press the **Setup** key.  
**Step 2.** Move the highlight to “**Printer**”.  
**Step 3.** Press on the strip.  
**Step 4.** Select the appropriate setting.

None	No printer is attached.
Local	A local printer is available
Remote 1	A remote (network) printer is available
Remote 2	A second remote (network) printer is available
Remote 3	A third remote (network) printer is available

- Step 5.** If you have finished configuring, exit the Setup menu.

## Selecting the Format for Short Reports

- Step 1.** Press the **Setup** key.  
**Step 2.** Scroll through the list, and select **Short Report**.  
**Step 3.** Select the time-span and resolution combination for your report.  
The first number indicates the total duration covered by the report, the second number is the interval between measurements. For example **4h@1min.** is a report for the last four hours, with measurement data from once every minute.

## Selecting the Format for Long Reports

**Step 1.** Press the **Setup** key.

**Step 2.** Scroll through the list, and select **Long Report**.

**Step 3.** Select the time-span and resolution combination for your report.

The first number indicates the total duration covered by the report, the second number is the interval between measurements. For example **24h@5min** is a report for the last twenty-four hours, with measurement data from once every 5 minutes.

## List of Configurable Settings

### General Settings

#### General Settings

Finding this setting in Configuration mode		Default Settings
Press <b>Setup</b> then <b>QuickSets</b>	Name of QuickSet 1	“QuickSet 1”
	Name of QuickSet 2	“QuickSet 2”
	Name of QuickSet 3	“QuickSet 3”
	Name of QuickSet 4	“QuickSet 4”
	Current QuickSet	“QuickSet1”
	Automatic Defaults <sup>a</sup>	No
Press <b>Setup</b> then <b>Exit Always</b>	Exit Always	No
Press <b>Setup</b> then <b>Altitude</b>	Altitude	0 m
Press <b>Setup</b> then <b>Printer</b>	Printer	Local
	Event Waves	3
	Paper Size	Univers.
Press <b>Setup</b> then <b>Remote Ctrls</b>	Remote Controls	Enabled
Press <b>Setup</b> then <b>QRS Type</b>	QRS Type	QRS Tone
Press <b>Setup</b> then <b>Admit. Discharge</b>	Patient Selection Default	Ask User
	Reset Always <sup>b</sup>	No
	Monitor Label	<empty>
	Hospital Label	<empty>

a. If monitor was switched off for more than 60 sec.

b. After PatID conflict resolution: settings are always reset to current Quick-Set.

### Quick Set Configuration List for the Measurements

When you have selected a Quick Set to be customized (see “Configuring the Monitor at installation” on page 351), press the Setup key in Configuration mode. Then work through all the settings as listed below. Items in the Setup window which are not listed below are not configurable. When this table with the measurements is completed, move on to the next table with monitoring settings.

## Measurements

	QuickSet1 (Adult ICU)	QuickSet2 (Adult OR)	QuickSet3 (Pediatric)	QuickSet4 (Neonatal)
Parameter / Item Name	Default Settings	Default Settings	Default Settings	Default Settings
<b>ECG - HR Settings<sup>a</sup></b>				
HR Alarms On/Off	on	on	on	on
HR High Limit	120 bpm	120 bpm	160 bpm	200 bpm
HR Low Limit	50 bpm	50 bpm	75 bpm	100 bpm
HR from	ECG	Auto	ECG	ECG
ECG on/off	on	on	on	on
Active ECG Channels	1	1	1	1
Analysis Mode	Multi-lead	Multi-lead	Single-lead	Single-lead
Lead Placement	Standard	Standard	Standard	Standard
Patient Paced	No	No	No	No
QRS Volume	0	0	0	0
Filter	Monitor	Monitor	Monitor	Monitor
Speed	25mm/s	25mm/s	25mm/s	25mm/s
Cascading	on	on	on	on
Auto Filter	off	off	off	off
Default Size (of ECG waves)	x1	x1	x1	x1
Color	green	green	green	green
Asystole Threshold	4.0 sec	4.0 sec	4.0 sec	3.0 sec
$\Delta$ ExtrTachy	20 bpm	20 bpm	20 bpm	20 bpm
Tachy Clamp	200 bpm	200 bpm	220 bpm	240 bpm
$\Delta$ ExtrBrady	20 bpm	20 bpm	20 bpm	20 bpm
Brady Clamp	40 bpm	40 bpm	40 bpm	50 bpm
HR Alarms On/Off	Enabled	Enabled	Enabled	Enabled
HR Selection	Enabled	Enabled	Enabled	Enabled
Fallback mode	on	on	on	on
All ECG (Alarms Off) INOP	on	on	on	on
Lead on Channel 1, 2, 3	II, V, III	II, V, III	II, V, III	II, V, III

## Measurements

	QuickSet1 (Adult ICU)	QuickSet2 (Adult OR)	QuickSet3 (Pediatric)	QuickSet4 (Neonatal)
Parameter / Item Name	Default Settings	Default Settings	Default Settings	Default Settings
<b>Arrhythmias</b>				
Non-Sustain	on	on	on	on
Vent Rhythm (on/off)	on	on	on	on
Run PVCs (on/off)	on	on	on	on
Pair PVCs	on	on	on	on
R-on-T PVCs	on	on	on	on
V. Bigeminy	on	on	on	on
V. Trigeminy	on	on	on	on
PVCs/min (on/off)	on	on	on	on
Multif. PVCs	on	on	on	on
Pacer N.Capt	on	on	on	on
Pacer N.Pac	on	on	on	on
Pause	on	on	on	on
Pause Alarm Threshold	2.0 sec	2.0 sec	2.0 sec	1.5 sec
Missed Beat	on	on	on	on
SVT	on	on	on	on
Irregular HR	on	on	on	on
VTach HR	100	100	120	150
VTach Run	5	5	5	5
Vent Rhythm	14	14	14	14
PVCs/min	10	10	5	5
SVT HR	180	180	200	210
SVT Run	5	5	5	5
Arrhythmia On/Off	on	on	on	off
TimeOut 1st (inhibit time for repeat alarms)	5 min	5 min	5 min	5 min
TimeOut 2nd (inhibit time for repeat alarms)	15 min	15 min	15 min	15 min
ArrhyOff Message	Yes	No	No	No



## Measurements

	QuickSet1 (Adult ICU)	QuickSet2 (Adult OR)	QuickSet3 (Pediatric)	QuickSet4 (Neonatal)
Parameter / Item Name	Default Settings	Default Settings	Default Settings	Default Settings
<b>ST</b>				
Alarms On/Off	on	on	on	on
ST <sub>I,II,III,aVR, aVL, aVF, V1-6, MCL</sub> High	+2.0 mm	+2.0 mm	+2.0 mm	+2.0 mm
ST <sub>I,II,III,aVR, aVL, aVF, V1-6, MCL</sub> Low	-2.0 mm	-2.0 mm	-2.0 mm	-2.0 mm
ST <sub>I,II,III,aVR, aVL, aVF, V, MCL</sub>	on	on	off	off
ST Analysis On/Off	on	on	off	off
ISO Point	-80 ms	-80 ms	-80 ms	-80 ms
J Point	48 ms	48 ms	48 ms	48 ms
ST Point	J+60	J+60	J+60	J+60
Color	yellow	yellow	yellow	yellow
<b>SpO<sub>2</sub></b>				
Alarms On/Off	on	on	on	on
High Alarm Limit	100	100	100	95
Low Alarm Limit	90	90	90	85
Desat Limit	80	80	80	80
Tone Modulation	No	Yes	No	No
QRS Volume	0	0	0	0
Pulse On/Off	Off	Off	Off	Off
Averaging Time	10 sec	10 sec	10 sec	10 sec
High Alarm Limit delay	10 sec	10 sec	10 sec	10 sec
Low Alarm Limit delay	10 sec	10 sec	10 sec	10 sec
Desat Alarm Limit delay	20 sec	20 sec	20 sec	20 sec
NBP Alarm Suppression	on	on	on	on
Color	cyan	cyan	cyan	cyan
<b>PRESS (for each label)</b>				
Parameter Alarms On/Off	on	on	on	on
Alarms from	Systolic	Systolic	Systolic	Systolic
High Alarm Limit	160 / 90 (110)	160 / 90 (110)	120 / 70 (90)	90 / 60 (70)
Low Alarm Limit	90 / 50 (70)	90 / 50 (70)	70 / 40 (50)	55 / 20 (35)

## Measurements

	QuickSet1 (Adult ICU)	QuickSet2 (Adult OR)	QuickSet3 (Pediatric)	QuickSet4 (Neonatal)
Parameter / Item Name	Default Settings	Default Settings	Default Settings	Default Settings
Label	ABP	ABP	ABP	ABP
Scale	100	100	60	60
PRESS(ABP) On/Off	On	On	On	On
Pressure Filter	12 Hz	12 Hz	12 Hz	12 Hz
Mean Only	Off	Off	Off	Off
Mercury Calibration enabled	yes	yes	yes	yes
S/D/M alarms parallel	no	no	no	no
Units	mmHg	mmHg	mmHg	mmHg
Color	red	red	red	red
<b>NBP</b>				
Alarms On/Off	on	on	on	on
Alarms from	Systolic	Systolic	Systolic	Systolic
High Alarm Limit	160 / 90 (110)	160 / 90 (110)	120 / 70 (90)	90 / 60 (70)
Low Alarm Limit	90 / 50 (60)	90 / 50 (60)	70 / 40 (50)	40 / 20 (24)
Auto/Man	automatic	automatic	automatic	manual
Repetition Time	15 min	15 min	15 min	15 min
NBP On/Off	on	on	on	on
S&D&M alarm	no	no	no	no
Units	mmHg	mmHg	mmHg	mmHg
Done tone	off	off	off	off
Start Time	NotSynch	NotSynch	NotSynch	NotSynch
VP pressure	60 mmHg	60 mmHg	40 mmHg	30mmHg
Color	red	red	red	red
Reference	Auscultatory	Auscultatory	Auscultatory	Invasive
<b>CO<sub>2</sub></b>				
CO <sub>2</sub> Alarms On/Off	on	on	on	on
EtCO <sub>2</sub> High Alarm Limit	50 mmHg	50 mmHg	50 mmHg	50 mmHg
EtCO <sub>2</sub> Low Alarm Limit	30 mmHg	30 mmHg	30 mmHg	30 mmHg
ImCO <sub>2</sub> High Alarm Limit	4 mmHg	4 mmHg	4 mmHg	4 mmHg

## Measurements

	QuickSet1 (Adult ICU)	QuickSet2 (Adult OR)	QuickSet3 (Pediatric)	QuickSet4 (Neonatal)
Parameter / Item Name	Default Settings	Default Settings	Default Settings	Default Settings
<b>AwRR Alarms<sup>b</sup></b>				
AwRR Alarm On/Off	on	on	on	on
AwRR High Alarm Limit	30 rpm	30 rpm	30 rpm	100 rpm
AwRR Low Alarm Limit	8 rpm	8 rpm	8 rpm	30 rpm
Apnea Time	20 sec	20 sec	20 sec	20 sec
Resp Source	Resp	AwRR	Resp	Resp
N <sub>2</sub> O Correction	off	off	off	off
Scale	40 mmHg	40 mmHg	40 mmHg	40mmHg
Resp. Speed	6.25 mm/s	6.25 mm/s	6.25 mm/s	6.25 mm/s
CO <sub>2</sub> On/Off	On	On	On	On
ImCO <sub>2</sub> Numeric	on	on	on	on
Units	mmHg	mmHg	mmHg	mmHg
Color	yellow	yellow	yellow	yellow
Max. Hold	off	off	off	off
Humidity Correction	BTPS	BTPS	BTPS	BTPS
<b>RESP</b>				
Alarms On/Off	on	on	on	on
High Alarm Limit	30 rpm	30 rpm	30 rpm	100 rpm
Low Alarm Limit	8 rpm	8 rpm	8 rpm	30 rpm
Apnea Time	20 sec	20 sec	20 sec	20 sec
Resp Source	Resp	AwRR	Resp	Resp
Auto/Manual	auto	auto	auto	auto
Resp. Speed	6.25 mm/s	6.25 mm/s	6.25 mm/s	6.25mm/s
Color	Yellow	Yellow	Yellow	Yellow
<b>TEMP (for each label)</b>				
Alarms On/Off	on	on	on	on
High Alarm Limit	39 °C	39 °C	39 °C	39 °C
Low Alarm Limit	36 °C	36 °C	36 °C	36 °C
Label (Measurement Server)	T1	T1	T1	T1

List of Configurable Settings

**Measurements**

	<b>QuickSet1 (Adult ICU)</b>	<b>QuickSet2 (Adult OR)</b>	<b>QuickSet3 (Pediatric)</b>	<b>QuickSet4 (Neonatal)</b>
<b>Parameter / Item Name</b>	<b>Default Settings</b>	<b>Default Settings</b>	<b>Default Settings</b>	<b>Default Settings</b>
T1 On/Off	Off	Off	Off	Off
Unit	<sup>0</sup> C	<sup>0</sup> C	<sup>0</sup> C	<sup>0</sup> C
Color	green	green	green	green
<b>Δ TEMP</b>				
Label	T1 -T2	T1 -T2	T1 -T2	T1 -T2
Δ TEMP On/Off	on	on	on	on
Unit	<sup>0</sup> C	<sup>0</sup> C	<sup>0</sup> C	<sup>0</sup> C
Color	green	green	green	green

- a. In monitor only visible if selected as HR source
- b. In monitor only visible if selected as Respiration source

## Quick Set Configuration List for Monitoring Settings

When you have finished customizing the measurements, move on in the Setup window to the QRS Volume setting. Items in the setup window which are not listed below are not configurable

### Monitoring Settings

	<b>QuickSet1 (Adult ICU)</b>	<b>QuickSet 2 (Adult OR)</b>	<b>QuickSet 3 (Pediatric)</b>	<b>QuickSet 4 (Neonatal)</b>
	<b>Default Settings</b>	<b>Default Settings</b>	<b>Default Settings</b>	<b>Default Settings</b>
QRS Volume	0	0	0	0
Alarm Volume	4	4	4	4
Brightness	Optimum	Optimum	Optimum	Optimum
<b>WAVES</b>				
Wave 1 Setup	ECG	ECG	ECG	ECG
Wave 2 Setup	Pleth	Pleth	Pleth	Pleth
Wave 3 Setup	Press 1	Press 1	Resp	Resp
Wave 4 Setup	Press 2	CO <sub>2</sub>	Blank	Blank
Auto Wave Assign	Yes	Yes	Yes	Yes
Cascading	On	On	On	On
Speed	25mm/s	25mm/s	25mm/s	25mm/s
Resp Speed	6.25mm/s	6.25mm/s	6.25mm/s	6.25mm/s
QUICK SETS	These are general settings, see "General Settings" on page 380.			
<b>ADMIT/DISCHARGE</b>				
Patient Cat.	Adult	Adult	Pedi	Neo
Patient Paced	No	No	No	No
PatSelDef	This is a general setting, see "General Settings" on page 380.			
Reset Always	This is a general setting, see "General Settings" on page 380.			
Monitor Label	This is a general setting, see "General Settings" on page 380.			
Hospital Label	This is a general setting, see "General Settings" on page 380.			
PRINTER	These are general settings, see "General Settings" on page 380.			
<b>ALARMS</b>				
Alarm Suspend	3 min.	Infinite	3 min.	3 min.
VisLatch	R&Y	Off	R&Y	R&Y

## Monitoring Settings

	QuickSet1 (Adult ICU)	QuickSet 2 (Adult OR)	QuickSet 3 (Pediatric)	QuickSet 4 (Neonatal)
	Default Settings	Default Settings	Default Settings	Default Settings
AudLatch	R&Y	Off	R&Y	R&Y
Alarm Reminder	On	Off	On	On
Alarm Rem Time	3 min.	3 min.	3 min.	3 min.
Alarm Keep Blink	No	No	No	No
Alarm Relay Sens	R&Y&I	R&Y&I	R&Y&I	R&Y&I
SuspRemind	Off	Off	Off	Off
AutoSuspend	Off	Off	Off	Off
<b>AUTO LIMITS</b>				
All	Enabled	Enabled	Enabled	Enabled
AutoLimits HR	Enabled	Enabled	Enabled	Enabled
AutoLimits ST	Enabled	Enabled	Enabled	Enabled
AutoLimits SpO <sub>2</sub>	Enabled	Enabled	Enabled	Enabled
AutoLimits Press 1	Enabled	Enabled	Enabled	Enabled
AutoLimits Press 2	Enabled	Enabled	Enabled	Enabled
AutoLimits NBP	Enabled	Enabled	Enabled	Enabled
AutoLimits EtCO <sub>2</sub>	Enabled	Enabled	Enabled	Enabled
AutoLimits RESP	Enabled	Enabled	Enabled	Enabled
AutoLimits Temp1	Enabled	Enabled	Enabled	Enabled
AutoLimits Temp2	Enabled	Enabled	Enabled	Enabled
<b>EVENTS</b>				
Event Conf HR	Off	Off	Off	Off
Event ConfPVC	Off	Off	Off	Off
Event Conf ST	Off	Off	Off	Off
Event Conf SpO <sub>2</sub>	Off	Off	Off	Off
Event Conf Press1	Off	Off	Off	Off
Event Conf Press2	Off	Off	Off	Off
Event Conf NBP	Off	Off	Off	Off
Event Conf CO <sub>2</sub>	Off	Off	Off	Off
Event Conf Resp	Off	Off	Off	Off

## Monitoring Settings

	QuickSet1 (Adult ICU)	QuickSet 2 (Adult OR)	QuickSet 3 (Pediatric)	QuickSet 4 (Neonatal)
	Default Settings	Default Settings	Default Settings	Default Settings
Event Conf Temp1	Off	Off	Off	Off
Event Conf Temp2	Off	Off	Off	Off
<b>Alarm Recordings</b>				
Recorder	Central	Central	Central	Central
AlarmRecord HR	Off	Off	Off	Off
AlarmRecordPVC	Off	Off	Off	Off
AlarmRecord ST	Off	Off	Off	Off
AlarmRecord SpO <sub>2</sub>	Off	Off	Off	Off
AlarmRecord Press1	Off	Off	Off	Off
AlarmRecord Press2	Off	Off	Off	Off
AlarmRecord NBP	Off	Off	Off	Off
AlarmRecord CO <sub>2</sub>	Off	Off	Off	Off
AlarmRecord Resp	Off	Off	Off	Off
AlarmRecord Temp1	Off	Off	Off	Off
AlarmRecord Temp2	Off	Off	Off	Off
QRS Type	This is a general setting, see “General Settings” on page 380.			
QRS Low	Inaudible	Inaudible	Inaudible	Inaudible
Alarm Low	Audible	Inaudible	Audible	Audible
Prompt Volume	4	4	4	4
Transport Brightn.	Optimum	Optimum	Optimum	Optimum
Meas Server Keys	Enabled	Enabled	Enabled	Enabled
Exit Always	This is a general setting, see “General Settings” on page 380.			
Display Units	No	No	No	No
<b>SMART KEYS</b>				
SmartKey A1	NBP	NBP	NBP	NBP
SmartKey A2	NBP Stop	NBP Stop	NBP Stop	NBP Stop
SmartKey A3	Delayed Rec.	Zero	Zero	Zero
SmartKey A4	Trends	Trends	Trends	Trends
SmartKey A5	Store Screen	Store Screen	Store Screen	Store Screen

## Monitoring Settings

	<b>QuickSet1 (Adult ICU)</b>	<b>QuickSet 2 (Adult OR)</b>	<b>QuickSet 3 (Pediatric)</b>	<b>QuickSet 4 (Neonatal)</b>
	<b>Default Settings</b>	<b>Default Settings</b>	<b>Default Settings</b>	<b>Default Settings</b>
SmartKey A6	Admit/Dischrg	Admit/Dischrg	Admit/Dischrg	Admit/Dischrg
SmartKey B1	Quick-Sets	QuickSets	Quick-Sets	Quick-Sets
SmartKey B2	QRS Volume	QRS Volume	QRS Volume	QRS Volume
SmartKey B3	Alarm Vol.	Alarm Vol.	Alarm Vol.	Alarm Vol.
SmartKey B4	Brightness	Brightness	Brightness	Brightness
SmartKey B5	Review Event	Review Event	Review Event	Review Event
SmartKey B6	Print-Screen	Print-Screen	Print-Screen	Print-Screen
SmartKey C1	ECG AutoSize	ECG AutoSize	ECG AutoSize	ECG AutoSize
SmartKey C2	Arrhy Relearn	Arrhy Relearn	Arrhy Relearn	Arrhy Relearn
SmartKey C3	Arrhy Annotat.	Arrhy Annotat.	Arrhy Annotat.	Arrhy Annotat.
SmartKey C4	Delayed Rec.	Limits Wide	Limits Wide	Blank
SmartKey C5	Record	NBP VeniPunct	Limits Narrow	Blank
SmartKey C6	Standby	Standby	Standby	Standby
SmartKey D1	NBP STAT	Blank	Blank	Blank
SmartKey D2	NBP Venipunct	Blank	Blank	Blank
SmartKey D3	Zero	Blank	Blank	Blank
SmartKey D4	Limits Wide	Blank	Blank	Blank
SmartKey D5	Limits Narrow	Blank	Blank	Blank
SmartKey D6	Standby	Blank	Blank	Blank
SmartKey E1	ECG Auto Size	Blank	Blank	Blank
SmartKey E2	Other Patient	Blank	Blank	Blank
SmartKey E3	Central Recording	Blank	Blank	Blank
SmartKey E4	Local Record	Blank	Blank	Blank
SmartKey E5	Local Delayed	Blank	Blank	Blank
SmartKey E6	Blank	Blank	Blank	Blank
SmartKey F1	Blank	Blank	Blank	Blank
SmartKey F2	Blank	Blank	Blank	Blank



**Monitoring Settings**

	<b>QuickSet1 (Adult ICU)</b>	<b>QuickSet 2 (Adult OR)</b>	<b>QuickSet 3 (Pediatric)</b>	<b>QuickSet 4 (Neonatal)</b>
	<b>Default Settings</b>	<b>Default Settings</b>	<b>Default Settings</b>	<b>Default Settings</b>
SmartKey F3	Blank	Blank	Blank	Blank
SmartKey F4	Blank	Blank	Blank	Blank
SmartKey F5	Blank	Blank	Blank	Blank
SmartKey F6	Blank	Blank	Blank	Blank
Operating Room	No	Yes	No	No
Short Report	2h @ 1min	2h @ 1min	2h @ 1min	2h @ 1min
Long Report	8h @ 5min	8h @ 5min	8h @ 5min	8h @ 5min
Auto Window	PatWin	Off	PatWin	PatWin
CareGrp Status	On	On	On	On
CentralMon	Optional	Optional	Optional	Optional
RemoteCtrls	This is a general setting, see “General Settings” on page 380.			
Altitude	This is a general setting, see “General Settings” on page 380.			

## List of Configurable Settings

# Monitor and Measurement Specifications

This chapter lists the performance specifications for the monitor and the measurement server.

- Monitor and Measurement Server Safety Specifications . . . . . 394
- Monitor Physical Specifications . . . . . 394
- Monitor Environmental Specifications . . . . . 395
- Monitor Performance Specifications . . . . . 396
- Measurement Server Physical Specifications . . . . . 399
- Measurement Server Environmental Specifications . . . . . 399
- ECG Specifications . . . . . 400
- RESP Specifications . . . . . 404
- SpO<sub>2</sub> Specifications . . . . . 406
- NBP Specifications . . . . . 408
- PRESS Specifications . . . . . 410
- TEMP Specifications . . . . . 411
- Measurement Server Extension Physical Specifications (M3015A and M3016A) . . . . . 412
- M3016A CO<sub>2</sub> Mainstream Measurement Specifications . . . . . 413
- M3015A CO<sub>2</sub> Microstream Measurement Specifications . . . . . 415
- Electromagnetic Compatibility (EMC) Specifications . . . . . 418
- Performing Safety and Performance Tests . . . . . 423

## Monitor and Measurement Server Safety Specifications

The M3046A monitor together with the M3001A Measurement Server comply with the Medical Device Directive 93/42/EEC (CE<sub>0366</sub>).

In addition, the product complies with

- IEC 60601-1:1988 + A1:1991 + A2:1995  
EN60601-1:1990 + A1:1993 + A2:1995
- IEC 60601-2-49:2001<sup>1</sup>  
EN 60601-2-49:2001
- UL 2601-1
- CAN/CSA C22.2#601.1-M90
- JIS T 1001-1992.

The possibility of hazards arising from software errors was minimized in compliance with EN1441 and EN60601-1-4.

---

## Monitor Physical Specifications

### Size

(W×D×H)

**Without Handle:**

210mm×135mm×210mm (8.27"×5.31"×8.27")

**With Handle:**

210mm×135mm×255mm (8.27"×5.31"×10")

### Weight

**Without battery:**

3200g (7.05lb)

---

1. At the time of printing, ECG lead sets with grabbers do not comply with clause 56.3 of IEC / EN 60601-2-49

---

## Monitor Environmental Specifications

### Temperature Range (without wireless network)

**Operating:**  
0 to 45°C (32 to 113°F).  
**Storage:**  
-20 to 60°C (-4 to 140°F).

### Temperature Range (with wireless network)

**Operating:**  
0 to 35°C (32 to 95°F).  
**Storage:**  
-20 to 60°C (-4 to 140°F).

### Humidity Range

**Operating:**  
95%RH max. @ 40°C (104°F)  
**Storage:**  
85%RH max. @ 50°C (122°F)  
Absolute humidity @ 50°C (122°F) shall not exceed the 85%RH/ 50°C level, which is equivalent to 50%RH max. @60°C (140°F).

### Altitude Range

**Operating:**  
-500m to 4,600m (-1,600' to 15,000')  
**Storage:**  
-500m to 13,100m (-1,600' to 43,000')

### Electrical Specifications

100 to 240VAC, 50/60Hz, 0.4 to 0.7A  
**Power Fail Protection.**

## Monitor Performance Specifications

### Display

6.5" (diagonal) active color LCD (TFT)

**Resolution:**

640×480 pixels

**Sweep speeds:**

6.25 mm/s, 12.5 mm/s, 25 mm/s, 50 mm/s **±10%**

### Indicators

- Up to 4 waves (dependent on Monitor Option)
- Alarms Off (red crossed-bell LED).
- Alarms (red/yellow LED, 4 different alarm tones).
- On/Off Standby (green LED).
- AC Power (green LED)
- Battery Status (green/yellow/red LED).
- QRS tone or tick, or SpO<sub>2</sub> modulation tone.

### Interfaces

- Server link between monitor and measurement server
- Network/Software Update (RJ45)
- Infrared interface to local printer (HP DeskJet 640C or LaserJet 4000 or 2100)
- Interface to monitors of the CMS family
- Serial recorder interface connector for GSI Lumonics XE-50p Recorder (Firmware Revision 4.1 supported)
- Nurse Call relay (1/8" phone jack, ≤60W, ≤2A, ≤36VDC, ≤25VAC, active=closed)  
Delay (alarm displayed on screen to activation of relay): < 1 second
- ECG Output/Marker Input (1/4" stereo phone jack with tip, ring, sleeve)

**ECG Output:**

Signal Gain: 320 to 3200 (depending upon ECG display gain)

Full Scale on Display: 3.2V<sub>pp</sub>

Gain Error: <20%

Baseline Offset: <150mV

Noise:<20mV<sub>RMS</sub> at signal gain 1000

Bandwidth: 1 to 80Hz in ECG Diagnostic mode

Output Impedance: <2.2KΩ±20% ECG Output (ring)

<2.5k $\Omega$   $\pm$ 20% ECG Output/Marker Input (tip)

Signal delay: <30ms

**Marker Input Requirements:**

Signal Type: 0 to -12V, negative edge pulse.

Pulse Source Impedance: <7k $\Omega$

Pulse Fall Time: <100 $\mu$ s

Pulse Duration: >4ms

- **VGA Interface**

Frame Frequency: 60 Hz

Row Frequency: 31.5 kHz

Resolution: 640 pixel x 480 pixel

Video Signal: 0.7V pp @ 75 $\Omega$

HSYNC/VSYNC Signal: TTL

Connector: 15-pin D-SUB

- **Wireless Network Interface (optional)**

Antenna: integrated into handle

Technology: Frequency Hopping Spread Spectrum (FHSS)

Frequency Band: 2.4 to 2.483 GHz (U.S. Version)

Output Power: 100 mW (max.)

Weight: <200g

**Battery  
(optional)**

Smart Battery Toshiba TR36 or Moltech NJ1020, 3500mAh (typ.),  
Nickel-Metal-Hydride (removable).

**Discharge Time:**

Operating time with a battery is specified as minimum 2 hour 30 minutes for standard Measurement Server and 2 hours 15 minutes when a CO<sub>2</sub> measurement is in use.

With a Wireless Network interface, operating time will be 15 minutes shorter.

**Charge Time (after connection to AC power):**

typically 24h with monitor on and functioning.

typically 4.5h with monitor off.

**Weight:**

600g (1.3lb)

## Monitor Performance Specifications

### **Real-time Clock**

**Accuracy:**

< 2 seconds per day.

**Operating Time:**

6h without battery or AC power, otherwise unlimited.

### **Active Settings and Stored Data**

**Operating Time:**

6h without battery or AC power, otherwise unlimited.

### **Trends**

**Short trend:**

10 hours with 1 minute resolution.

**Long trend:**

48 hours with 5 minutes resolution.

Both trends are stored



---

## Measurement Server Physical Specifications

<b>Size</b>	(W×D×H) 188.0mm×96.5mm×51.5mm (7.40"×3.80"×2.03")
<b>Weight</b>	650g (1.4lb)

---

## Measurement Server Environmental Specifications

<b>Temperature Range</b>	<b>Operating:</b> 0 to 45°C (32 to 113°F).
	<b>Storage:</b> -40 to 70°C (-40 to 158°F).
<b>Humidity Range</b>	<b>Operating:</b> 95%RH max. @ 40°C (104°F)
	<b>Storage:</b> 90%RH max. @ 65°C (150°F)
<b>Altitude Range</b>	<b>Operating:</b> -500 to 4,600m (-1,600' to 15,000')
	<b>Storage:</b> -500 to 15,300m (-1,600' to 50,000')

---

## ECG Specifications

Complies with IEC 60601-2-27/EN60601-2-27

**Differential Input Impedance**                      Greater than  $2M\Omega$  RA-LL leads (Resp). Greater than  $5M\Omega$  at all other leads (at 10Hz including patient cable).

**Common Mode Rejection Ratio**                      *Diagnostic mode:*  
Greater than 86dB (with a  $51k\Omega/47nF$  imbalance).  
*Filter mode:*  
Greater than 106dB (with a  $51k\Omega/47nF$  imbalance).

**Electrode Offset Potential Tolerance**                       $\pm 500mV$

**Auxiliary Current**                      *Active electrode:*  
Less than 100nA  
*Reference electrode:*  
Less than 400nA  
12-lead: less than 900nA

**Baseline Recovery Time**                      Less than 1 second after defibrillation.

**Input Signal Range**                       $\pm 5mV$

**Calibration**                      *Signal:*  
 $1mV_{p-p}$

**Accuracy:**  
 $\pm 10\%$

## Bandwidth

**Diagnostic Mode**

*Adult:* 0.05 to 150Hz

*Neo/pedi:* 0.5 to 150Hz

**Monitoring Mode**

*Adult:* 0.5 to 40Hz

*Neo/pedi:* 0.5 to 55Hz

**Filter Mode**

0.5 to 20Hz

---

## Arrhythmia Specifications

### Cardiotach

*Adult/pedi range:* 15 to 300bpm

*Neo range:* 15 to 350bpm

**Accuracy:**  
 $\pm 1\%$  of range

**Resolution:**  
 1 bpm

**Sensitivity:**  
 $\geq 200\mu V_{\text{peak}}$

### PVC Rate

**Range:**  
 0 to 300 bpm

**Resolution:**  
 1 bpm

### Limit Alarms for Heart Rate

**Range:**  
 15 to 300 bpm

**Adjustment:**  
 Adult: 15 - 40 bpm : 1 bpm steps  
 40 - 300 bpm : 5 bpm steps

## Arrhythmia Specifications

Neo/Pedi: 15 - 50 bpm : 1 bpm steps  
50 - 300 bpm : 5 bpm steps

### **Alarm Delay**

**High and Low alarm:**

10 seconds according to AAMI EC 13-1992 standard

### **Extreme Tachy**

**Difference to high limit:**

0 to 50 bpm

**Clamping at:**

150 to 300 bpm

**Adjustment:**

5 bpm steps

### **Extreme Brady**

**Difference to low limit:**

0 to 50 bpm

**Clamping at:**

15 to 100 bpm

**Adjustment:**

5 bpm steps

### **Run PVCs Limit**

**Range:**

2 PVCs

**Adjustment:**

Not adjustable by user

### **PVCs Rate Limit**

**Range:**

1 to 99 PVCs/min

**Adjustment:**

1 PVC

### **Vent Tach HR**

**Range:**

20 to 300 bpm

**Adjustment:**

5 bpm

**Vent Tach  
Run Limit**  
**Range:**  
3 to 99 PVCs/min  
**Adjustment:**  
1 PVC

**Vent  
Rhythm Run  
Limit**  
**Range:**  
2 to 99 PVCs/min  
**Adjustment:**  
1 PVC

**SVT HR  
Limit**  
**Range:**  
120 to 300 bpm  
**Adjustment:**  
5 bpm

**SVT Run  
Limit**  
**Range:**  
3 to 99 SV beats  
**Adjustment:**  
1 SV beat

**Asystole  
Threshold**  
**Range:**  
2.5 to 4.0 sec  
**Adjustment:**  
0.5 sec steps

**Pause  
Threshold**  
**Range:**  
1.5 to 2.5 sec  
**Adjustment:**  
0.5 sec steps

## ST Specifications

### ST Numeric

**Range:**

-20 to +20 mm

**Resolution:**

0.1 mm

**Accuracy:**

±0.5 mm or 15%, whichever is greater

### ST High Limit

**Range:**

-20 to +20 mm

**Adjustment:**

0.2 mm

### ST Low Limit

**Range:**

-20 to +20 mm

**Adjustment:**

0.2 mm

---

## RESP Specifications

### Bandwidth

0.3 to 2.5Hz (-6dB)

### Noise

Less than 25mΩ (rms) referred to the input.

### Respiration Rate

*Adult/pedi:* 0 to 120rpm

*Neo:* 0 to 170rpm

**Accuracy:**

±1rpm @ 0 to 120rpm

±2rpm @ 120 to 170rpm

	<b>Resolution:</b> 1rpm
<b>Calibration Signal</b>	<b>Signal:</b> $1\Omega_{p-p}$ <b>Accuracy:</b> $\pm 20\%$
<b>Respiration Limit Alarms</b>	<b>High range:</b> <i>Adult/pedi:</i> 10 to 100rpm <i>Neo:</i> 30 to 150rpm <b>Low Range:</b> <i>Adult/pedi:</i> 0 to 95rpm <i>Neo:</i> 0 to 145rpm <b>Adjustment:</b> <i>under 20rpm:</i> 1rpm steps <i>over 20rpm:</i> 5rpm steps <b>High Alarm Delay:</b> 14 seconds. <b>Low Alarm Delay:</b> <i>for settings below 20rpm:</i> 4 seconds <i>above 20rpm:</i> 14 seconds
<b>Apnea Alarm</b>	<b>Delay Range:</b> 10 to 40 seconds <b>Adjustment:</b> 5 second steps

## SpO<sub>2</sub> Specifications

**Range** 0 to 100%.

### Accuracy

**Measurement validation:**

The SpO<sub>2</sub> accuracy has been validated in human studies against arterial blood sample reference measured with a co-oximeter.

(SD= Standard Deviation)

**Accuracy with Philips Reusable Transducers:**

M1191A, M1192A

*ISD = ±2.5% (70% to 100%)*

M1193A, M1195A

*ISD = ±3% (70% to 100%)*

M1194A

*ISD = ±4% (70% to 100%)*

**Accuracy with NellcorPB<sup>®</sup> Disposable Transducers (M1901A/B, M1902A/B, M1903A/B, M1904A/B) and NellcorPB<sup>®</sup> Transducers (D-25, D-20, I-20, N-25, OxiCliq A, P, I, N):**

*ISD = ±3% (70% to 100%)*

**Resolution** 1%

### Limit Alarms

**Adult**

**High range:**

51 to 100% SpO<sub>2</sub>

**Low range:**

50 to 99% SpO<sub>2</sub>

**Neo/Pedi**

**High range:**

31 to 100% SpO<sub>2</sub>



**Low range:**30 to 99% SpO<sub>2</sub>**Adjustment:**

1% steps

**High alarm delay** (configurable setting):

(0, 1, 2, 3,...30) + 4 seconds

**Low alarm delay** (configurable setting):

(0, 1, 2, 3,...30) + 4 seconds

**Desat Limit:**

Adult: 50 to Low Alarm Limit

Neo/Pedi: 30 to Low Alarm Limit

**Desat Delay** (configurable setting):

(0, 1, 2, 3,...30) + 4 seconds

**Pulse Rate  
Measurement Range**

30 to 300bpm.

**Accuracy**

±2%

**Resolution:**

1bpm.

**Pulse Rate  
Limit  
Alarms**

30 to 300bpm

**Adjustment:**

5bpm steps

**High and low alarm delay:**

14 seconds.

**Display  
Update  
Period**

Typical: 2 seconds

Maximum: 30 seconds

Maximum with NBP INOP suppression on: 60 seconds

**SpO<sub>2</sub>  
Transducers****Wavelength range:**

600 to 1000 nm

**Emitted Light Energy:**

≤ 5mW

## NBP Specifications

Complies with IEC 60601-2-30/EN60601-2-30

### Cuff Inflation Rate

**typical for normal adult cuff:**

Less than 10 seconds

### Auto Mode Repetition

1, 2, 2.5, 3, 5, 10, 15, 20, 30, 45, 60 or 120 minutes

### STAT Mode Cycle Time

5 minutes.

### Venipuncture Mode Inflation

**Adult:**

20 to 120 mmHg (3 to 16 kPa)

**Pediatric:**

20 to 80 mmHg (3 to 11 kPa)

**Neonatal:**

20 to 50 mmHg (3 to 7 kPa)

Automatic deflation after:

*Adult/pediatric:*

170 seconds

**Neonatal:**

85 seconds

### Measurement Time

(Typical at HR > 60bpm)

**Auto/manual:**

30 seconds (adult)

25 seconds (neonatal)

**Stat:**

20 seconds.

<b>Accuracy</b>	<p><b>Maximum Standard Deviation:</b> 8mmHg. (1.1kPa)</p> <p><b>Maximum Mean Error:</b> ±5mmHg (±0.7kPa)</p>
<b>Heart Rate Range</b>	40 to 300bpm.
<b>Measurement Validation</b>	<p>In adult and pediatric mode, the blood pressure measurements determined with this device comply with the American National Standard for Electronic or Automated Sphygmomanometers (ANSI/AAMI SP 10/92) in relation to mean error and standard deviation, when compared to intra-arterial or auscultatory measurements (depending on the configuration) in a representative patient population. For the auscultatory reference, the 5th Korotkoff sound was used to determine the diastolic pressure.</p> <p>In neonatal mode, the blood pressure measurements determined with this device comply with the American National Standard for Electronic or Automated Sphygmomanometers (ANSI/AAMI SP 10/92) in relation to mean error and standard deviation, when compared to intra-arterial measurements in a representative patient population.</p>
<b>Adult Mode</b>	<p><b>Measurement Ranges</b></p> <p><b>Systolic:</b> 30 to 270mmHg (4.0 to 36.0kPa)</p> <p><b>Diastolic:</b> 10 to 245mmHg (1.5 to 32.0kPa)</p> <p><b>Mean:</b> 20 to 255mmHg (2.5 to 34.0kPa)</p>
<b>Pediatric Mode</b>	<p><b>Measurement Ranges</b></p> <p><b>Systolic:</b> 30 to 180mmHg (4.0 to 24.0kPa)</p> <p><b>Diastolic:</b> 10 to 150mmHg (1.5 to 20.0kPa)</p> <p><b>Mean:</b> 20 to 160mmHg (2.5 to 21.0kPa)</p>
<b>Neonatal Mode</b>	<p><b>Measurement Ranges</b></p> <p><b>Systolic:</b> 30 to 130mmHg (4.0 to 17.0kPa)</p> <p><b>Diastolic:</b> 10 to 100mmHg (1.5 to 13.0kPa)</p> <p><b>Mean:</b> 20 to 120mmHg (2.5 to 16.0kPa)</p>

## PRESS Specifications

Complies with IEC 60601-2-34/EN60601-2-34

### Input Sensitivity

5 $\mu$ V/V/mmHg (37.5 $\mu$ V/V/kPa)

#### Sensitivity Adjustment Range

$\pm 10\%$

### Zero Adjustment

#### Range:

$\pm 200$  mmHg ( $\pm 26.0$  kPa)

#### Accuracy:

$\pm 1$  mmHg ( $\pm 0.1$  kPa)

#### Drift:

Less than 0.1 mmHg/ $^{\circ}$ C  
(0.013 kPa/ $^{\circ}$ C)

### Gain Accuracy (excluding transducers)

#### Accuracy:

$\pm 1\%$  Full Scale (FS)

#### Drift:

Less than 0.05%/ $^{\circ}$ C

#### Non linearity and Hysteresis:

Error of less than, or equal to 0.4% FS (@ CAL 200 mmHg)

#### Transducer Load Impedance:

200 to 2000  $\Omega$  (resistive)

### Overall Accuracy (including transducers)

$\pm 4\%$  of reading or  $\pm 4$  mmHg ( $\pm 0.5$  kPa) whichever is greater

### Transducer Output Impedance:

$\leq 3000$   $\Omega$  (resistive)

<b>Volume Displacement (CPJ840J6 Transducer)</b>	0.1 mm <sup>3</sup> / 100 mmHg
<b>Measurement Range:</b>	– 40 to 360 mmHg
<b>Frequency Response:</b>	dc to 12.5Hz or 40Hz.
<b>Limit Alarms</b>	– 40 to 360mmHg (–5.0 to 48 kPa). <b>Alarm Delay:</b> 12 seconds
<b>Pulse Rate Measurement Range</b>	25 to 350bpm <b>Accuracy:</b> ±1% Full Range <b>Resolution:</b> 1bpm.
<b>Pulse rate Limit Alarms</b>	30 to 300bpm

---

## TEMP Specifications

<b>Measurement Range</b>	–1 to 45°C (30 to 113°F). <b>Resolution:</b> 0.1°C (0.2°F).
--------------------------	---

## Measurement Server Extension Physical Specifications (M3015A and M3016A)

**Accuracy:**  
 $\pm 0.1^{\circ}\text{C}$  ( $\pm 0.2^{\circ}\text{F}$ ).

**Average Time Constant** Less than 10 seconds.

**Test Temperature**  $40^{\circ}\text{C} \pm 0.1^{\circ}\text{C}$  ( $104^{\circ}\text{F} \pm 0.2^{\circ}\text{F}$ ).

**Limit Alarms** **Range:**  
 $-1$  to  $45^{\circ}\text{C}$  (30 to  $113^{\circ}\text{F}$ ).

---

## Measurement Server Extension Physical Specifications (M3015A and M3016A)

**Size** (W×D×H)  
 $188.0\text{mm} \times 96.5\text{mm} \times 38.5\text{mm}$  ( $7.40'' \times 3.80'' \times 1.52''$ )

**Weight**  
**M3015A:**  
550g (1.21 lb)  
**M3016A:**  
450g (0.99 lb)

## Measurement Server Extension Environmental Specifications (M3015A and M3016A)

### Temperature Range

**Operating:**  
0 to 45°C (32 to 113°F).

**Storage:**  
-40 to 70°C (-40 to 158°F).

### Humidity Range

**Operating:**  
95%RH max. @ 40°C (104°F), non-condensing

**Storage:**  
90%RH max. @ 65°C (150°F)

### Altitude Range

**Operating:**  
-500 to 4,600m (-1,600' to 15,000')

**Storage:**  
-500 to 15,300m (-1,600' to 50,000')

---

## M3016A CO<sub>2</sub> Mainstream Measurement Specifications

Complies with EN864/ISO9918 except EN 475

### Measurement Range

-4 to 150 mmHg (-0.5 to 20.0 kPa).

### Warm-up Time

20 minutes with CO<sub>2</sub> transducer attached for full accuracy specification.

**Accuracy  
(after 20  
minutes  
warm-up and  
calibration)**

These specifications are valid for 45% O<sub>2</sub> and N<sub>2</sub> or N<sub>2</sub>O balance. Outside these conditions the accuracy reaches at a minimum the requirements of EN864/ISO9918.

*For values between 0 and 40 mmHg (0 to 5.3 kPa)*  
±2.2 mmHg (±0.3 kPa)  
*For values above 40mmHg (5.3 kPa)*  
±5.5% of reading

**Resolution**

**Numeric:**  
1.0 mmHg (0.1 kPa)  
**Wave:**  
0.1 mmHg (0.01 kPa)

**Stability**

±1.0 mmHg over a 7 day period

**Endtidal  
CO<sub>2</sub>  
(etCO<sub>2</sub>)  
Limit  
Alarms**

**High Range:**  
20 to 95 mmHg (2 to 13.0kPa)  
**Low Range:**  
10 to 90 mmHg (1 to 12.0kPa)  
**Alarm Delay:**  
14 seconds.

**Inspired  
minimum  
(imCO<sub>2</sub>)  
High Limit  
Alarm**

**Range:**  
2 to 20 mmHg (0.3 to 3.0 kPa)  
**Adjustment Steps:**  
1 mmHg (0.1 kPa)  
**Alarm Delay:**  
14 seconds

**Rise Time**

Step response from 10% to 90%:  
  
Less than 125 ms (for step)



## M3015A CO<sub>2</sub> Microstream Measurement Specifications

Complies with EN864/ISO9918 except EN 475

### Measurement Range

0 to 98mmHg (0.0 to 13.0 kPa), or 13% CO<sub>2</sub>, whichever is lower.

### Warm-up Time

5 minutes for an accuracy of  $\pm 4$  mmHg or  $\pm 12\%$  of reading, whichever is greater. 20 minutes for full accuracy specification.

### Accuracy (after 20 minutes warm-up)

**0 to 40 mmHg (0 to 5.3 kPa):**

$\pm 2.2$  mmHg ( $\pm 0.3$  kPa)

**Above 40mmHg (5.3 kPa):**

$\pm \{5.5\% + (0.08\% \text{ per mmHg above } 40 \text{ mmHg})\}$  of reading

These specifications are valid for:

- 21% O<sub>2</sub> and N<sub>2</sub> balance
- up to 35°C ambient temperature
- up to 60 rpm for adults and 100 rpm for neonates.

Outside of these conditions the accuracy is  $\pm 4$  mmHg or  $\pm 12\%$ , whichever is greater

### Resolution

**Numeric:**

1.0 mmHg (0.1 kPa)

**Wave:**

0.1 mmHg (0.01 kPa)

### Sample Flow Rate

50  $\pm$  7.5 ml/min

### Rise Time

Step response 10% - 90%:

- 190 ms for neonatal mode (measured with M1923A FilterLine H Set Infant/ Neonatal).

- 240 ms for adult mode (measured with M1921A FilterLine H Set Adult/ Pediatric sample line for humidified ventilation and airway adapter).

**Gas Sampling Delay Time**

Sampling delay time from an input step change at the airway adapter until the measured signal changes by 10% of the input step (using M1920A FilterLine Set Adult/Pediatric).

**Step response 0% - 10%:**

- 2.3 seconds -typical
- 3 seconds - maximum

**Endtidal CO<sub>2</sub> (etCO<sub>2</sub>) Limit Alarms**

**High Range:**

20 to 95 mmHg (2.0 to 13.0 kPa)

**Low Range:**

10 to 90 mmHg (1.0 to 12.0 kPa)

**Adjustment Steps:**

1 mmHg (0.1 kPa) steps

**Alarm Delay:**

18 seconds

**Inspired minimum (imCO<sub>2</sub>) High Limit Alarm**

**Range:**

2 to 20 mmHg (0.3 to 3.0 kPa)

**Adjustment Steps:**

1 mmHg (0.1 kPa)

**Alarm Delay:**

18 seconds

---

## M3015A/M3016A AwRR Specifications

**Range** 0 to 150 rpm

**Accuracy** M3016A:  $\pm 2$  rpm  
M3015A:  
0 to 40 rpm:  $\pm 1$  rpm  
41 to 70 rpm:  $\pm 2$  rpm  
71 to 100 rpm:  $\pm 3$  rpm  
>100 rpm:  $\pm 5\%$  of reading

## **Limit Alarms**

### **High range:**

*Adult/pedi:* 10 to 100rpm

*Neo:* 30 to 150rpm

### **Low Range:**

*Adult/pedi:* 0 to 95rpm

*Neo:* 0 to 145rpm

### **Adjustment:**

*under 20rpm:* 1rpm steps

*over 20rpm:* 5rpm steps

### **High Alarm Delay:**

18 seconds.

### **Low Alarm Delay:**

*for settings below 20rpm:* 8 seconds

*above 20rpm:* 18 seconds

## **Apnea Alarm**

### **Delay Range:**

10 to 40 seconds

### **Adjustment:**

5 second steps

---

## **M3015A/M3016A Press Specifications**

see “PRESS Specifications” on page 410 for the Measurement Server

---

## **M3015A/M3016A Temp. Specifications**

see “TEMP Specifications” on page 411 for the Measurement Server.

---

## M3015A/M3016A Difference Temperature Specifications

**Measurement Range**             $\pm 46^{\circ}\text{C}$  ( $\pm 115^{\circ}\text{F}$ )

**Accuracy (excluding probe)**             $\pm 0.1^{\circ}\text{C}$  ( $\pm 0.2^{\circ}\text{F}$ )

---

## Electromagnetic Compatibility (EMC) Specifications

Take special precautions regarding electromagnetic compatibility (EMC) when using medical electrical equipment. You must install and operate your monitoring equipment according to the EMC information provided in this book. Portable and mobile radio frequency (RF) communications equipment can affect medical electrical equipment.

**Accessories Compliant with EMC Standards**            All accessories listed in the accessories section are compliant with the requirements of IEC 60601-1-2.

---

---

**Warning**            **Using accessories other than those specified may result in increased electromagnetic emission or decreased electromagnetic immunity of the monitoring equipment.**

---

---

**Electromagnetic Emissions**            The monitor together with the M3001A Measurement Server and the M3015A and M3016A Measurement Server Extensions is suitable for use in the electromagnetic environment specified in the table below. You must ensure that it is used in such an environment.

Emissions test	Compliance	Electromagnetic environment guidance
RF emissions	Group 1	The monitor uses RF energy only for its internal function. Therefore, its RF emissions are very low and are not likely to cause any interference in nearby electronic equipment.
RF emissions CISPR 11	Class A	The monitor is suitable for use in all establishments other than domestic and those directly connected to the public low-voltage power supply network that supplies buildings used for domestic purposes
Harmonic emissions IEC 61000-3-2	n/a	
Voltage fluctuations IEC 61000-3-3	n/a	

**Warning**

**The monitor should not be used next to or stacked with other equipment. If you must stack the monitor, you must check that normal operation is possible in the necessary configuration before you start monitoring patients.**

**Electromagnetic Immunity**

The monitor is suitable for use in the specified electromagnetic environment. The user must ensure that it is used in the appropriate environment as described below.

Immunity test	IEC 60601-1-2 test level	Compliance level	Electromagnetic environment guidance
Electrostatic discharge (ESD) IEC 61000-4-2	± 6 kV contact ± 8kV air	± 6 kV contact ± 8kV air	Floors should be wood, concrete, or ceramic tile. If floors are covered with synthetic material, the relative humidity should be at least 30%.
Electrical fast transient/burst IEC 61000-4-4	± 2 kV for power supply lines ± 1 kV for input/output lines	± 2 kV for power supply lines ± 1 kV for input/output lines	Mains power quality should be that of a typical commercial and/or hospital environment

Immunity test	IEC 60601-1-2 test level	Compliance level	Electromagnetic environment guidance
Surge IEC 61000-4-5	± 1 kV differential mode ± 2 kV common mode	± 1 kV differential mode ± 2 kV common mode	Mains power quality should be that of a typical commercial and/or hospital environment
Voltage dips, short interruptions and voltage variations on power supply input lines IEC 61000-4-11	<5% $U_T$ (> 95% dip in $U_T$ ) for 0.5 cycles 40% $U_T$ (60% dip in $U_T$ ) for 5 cycles 70% $U_T$ (30% dip in $U_T$ ) for 25 cycles < 5% $U_T$ (> 95% dip in $U_T$ ) for 5 sec	<5% $U_T$ (> 95% dip in $U_T$ ) for 0.5 cycles 40% $U_T$ (60% dip in $U_T$ ) for 5 cycles 70% $U_T$ (30% dip in $U_T$ ) for 25 cycles < 5% $U_T$ (> 95% dip in $U_T$ ) for 5 sec	Mains power quality should be that of a typical commercial and/or hospital environment. If the user of the monitor requires continued operation during power mains interruptions, it is recommended that the monitor is equipped with an internal battery or is powered from an uninterruptible power supply.
Power frequency (50/60 Hz) magnetic field IEC 61000-4-8	3 A/m	3 A/m	Power frequency magnetic fields should be at levels characteristic of a typical location in a typical commercial and/or hospital environment

In this table,  $U_T$  is the a.c. mains voltage prior to application of the test level.

## Recommended Separation Distance

---



---

### Warning

**The monitor equipped with a wireless network interface intentionally receives RF electromagnetic energy for the purpose of its operation. Therefore, other equipment may cause interference, even if that other equipment complies with CISPR emission requirements.**

---



---

In the following table, P is the maximum output power rating of the transmitter in watts (W) according to the transmitter manufacturer and d is the recommended separation distance in metres (m).

Portable and mobile RF communications equipment should be used no closer to any part of the monitor, including cables, than the recommended separation distance calculated from the equation appropriate for the frequency of the transmitter.

Field strengths from fixed RF transmitters, as determined by an electromagnetic site survey, should be less than the compliance level in each frequency range (over the frequency range 150 kHz to 80 MHz, field strengths should be less than 1 V/m for respiration and 3 V/m for all other functions).

Interference may occur in the vicinity of equipment marked with the following symbol:



Immunity Test	IEC 60601-1-2 Test Level	Compliance Level	Electromagnetic Environment Guidance
Conducted RF IEC 61000-4-6	3 V <sub>RMS</sub> 150 kHz to 80 Mhz	3 V <sub>RMS</sub> (1 V <sub>RMS</sub> for respiration )	Recommended separation distance: $d = 1, 2\sqrt{P}$
Radiated RF IEC 61000-4-3	3 V/m 80 Mhz to 2.5 GHz	3 V/m (1 V/m for respiration)	Recommended separation distance: 80 MHz to 800 MHz $d = 1, 2\sqrt{P}$  80 MHz to 800 MHz for respiration: $d = 3, 5\sqrt{P}$  800 MHz to 2,5 GHz $d = 2, 3\sqrt{P}$  800 MHz to 2,5 GHz for respiration: $d = 7, 0\sqrt{P}$

Field strengths from fixed transmitters, such as base stations or radio (cellular, cordless) telephones and land mobile radios, amateur radio, AM and FM radio broadcast and TV broadcast cannot be predicted theoretically with accuracy. To

assess the electromagnetic environment due to fixed RF transmitters, an electromagnetic site survey should be considered. If the measured field strength in the location in which the monitor is used exceeds the applicable RF compliance level above, the monitor should be observed to verify normal operation. If abnormal performance is observed, additional measures may be necessary, such as reorienting or relocating the monitor.

These guidelines may not apply in all situations. Electromagnetic propagation is affected by absorption and reflection from structures, objects, and people.

**Recommended separation distances from portable and mobile RF communication equipment**

The monitor is intended for use in an electromagnetic environment in which radiated RF disturbances are controlled. The customer or user of the monitor can help prevent electromagnetic interference by maintaining a minimum distance between portable and mobile RF communications equipment and the monitor as recommended below, according to the maximum output power of the communications equipment.

Frequency of transmitter	150 kHz to 80 MHz	150 kHz to 800 MHz	800 MHz to 2,5 GHz
Equation	$d = 1, 2\sqrt{P}$ For respiration: $d = 3, 5\sqrt{P}$	$d = 1, 2\sqrt{P}$ For respiration: $d = 3, 5\sqrt{P}$	$d = 2, 3\sqrt{P}$ For respiration: $d = 7, 0\sqrt{P}$
Rated max. output power of transmitter (W)	Separation distance (m)	Separation distance (m)	Separation distance (m)
0.01	0.1 (0.4)	0.1 (0.4)	0.2 (0.7)
0.1	0.4 (1.1)	0.4 (1.1)	0.7 (2.2)
1	1.2 (3.5)	1.3 (3.5)	2.3 (7.0)
10	3.8 (11.1)	3.8 (11.1)	7.3 (22.1)
100	12.0 (35.0)	12.0 (35.0)	23.0 (70.0)

**The values for respiration are given in parentheses.**

For transmitters rated at a maximum output power not listed above, the separation distance can be estimated using the equation in the corresponding



column, where P is the maximum output power rating of the transmitter in watts (W) according to the transmitter manufacturer.

These guidelines may not apply in all situations. Electromagnetic propagation is affected by absorption and reflection from structures, objects, and people.

**Electrosurgery  
Interference/  
Electrostatic  
Discharge**

The equipment will return to the previous operating mode within 10 seconds without loss of any stored data. Measurement accuracy may be temporarily decreased while performing electrosurgery or defibrillation. This does not affect patient or equipment safety. Do not expose the equipment to x-ray or strong magnetic fields (MRI).

**Fast Transients/  
Bursts**

The equipment will return to the previous operating mode within 10 seconds without loss of any stored data. If any user interaction is required, the monitor will indicate this by a technical alarm (INOP).

---

## Performing Safety and Performance Tests

Contact your biomedical department if your monitor or Measurement Server needs testing for safety or performance.

The Safety and Performance Tests, and what to do if the instrument does not meet these specifications are described in the latest Service Guide.

Performing Safety and Performance Tests

# Accessories and Ordering Information

This chapter lists the accessories recommended for use with the monitor and the measurement server.

- ECG Accessories . . . . . 426
- SpO<sub>2</sub> Accessories . . . . . 429
- NBP Accessories . . . . . 431
- PRESS Accessories . . . . . 433
- Mainstream CO<sub>2</sub> Accessories . . . . . 434
- Microstream CO<sub>2</sub> Accessories (Sidestream) . . . . . 435
- TEMP Accessories . . . . . 436
- Monitor Mounting Options . . . . . 437
- Server Mounting Options . . . . . 438
- Recorder . . . . . 438
- Recorder Mounting Options . . . . . 438
- Recorder Paper . . . . . 438

---

## Caution

---

The following Philips parts and accessories are specified for used with the Monitor, Measurement Server and Measurement Server Extensions. If non-Philips parts are used, Philips is not liable for any damage that these parts may cause to the equipment.

---

---

---

## ECG Accessories



The heart symbol signifies that the applied parts and their components are of Type CF and defib. proof according to IEC60601-1/EN60601-1.

### Trunk Cable

#### 3-Electrode

AAMI	0.9m	M1540C
	2.7m	M1500A
IEC	0.9m	M1550C
	2.7m	M1510A

#### 5-Electrode

AAMI	0.9m	M1560C
	2.7m	M1520A
IEC	0.9m	M1570C
	2.7m	M1530A

#### 5-Electrode

AAMI/IEC	2.7m	M1949A
----------	------	--------

#### 10-Electrode

AAMI/IEC	2.7m	M1949A
----------	------	--------

### 3-Electrode Cable Sets

#### AAMI

OR	1.0m	M1601A
ICU:		
Grabber	1.0m	M1603A
Snap	1.0m	M1605A
Non-shielded	0.45m	M1608A
Non-shielded	0.7m	M1609A

#### IEC

OR	1.0m	M1611A
ICU:		
Grabber	1.0m	M1613A
Snap	1.0m	M1615A
Non-shielded	0.7m	M1619A

**5-Electrode Cable Sets***AAMI*

OR	1.0/1.6m	M1621A
ICU:		
Grabber	1.0/1.6m	M1623A
Snap	1.0/1.6m	M1625A
Non-shielded	0.7/1.3m	M1629A

*IEC*

OR	1.0/1.6m	M1631A
ICU:		
Grabber	1.0/1.6m	M1633A
Snap	1.0/1.6m	M1635A
Non-shielded	0.7/1.3m	M1639A

**10-Electrode Cable Sets***AAMI*

OR:		
Grabber - extremities	1.0/1.6m	M1973A
Grabber - chest	1.0m	M1979A
ICU:		
Snap	1.0/1.6m	M1968A
Snap - chest	1.0m	M1976A

*IEC*

OR:		
Grabber - extremities	1.0/1.6m	M1974A
Grabber - chest	1.0m	M1984A
ICU:		
Grabber - extremities	1.0/1.6m	M1971A
Grabber - chest	1.0m	M1978A

**3-Electrode One Piece Cables***AAMI*

OR	1.9m	M1970A
ICU (Snap)	1.9m	M1972A

*IEC*

OR	1.9m	M1980A
ICU (Grabber)	1.9m	M1981A

**5-Electrode One Piece Cables**

*AAMI*

OR	2.5m	M1975A
ICU (Snap)	2.5m	M1977A

*IEC*

OR	2.5m	M1985A
ICU (Grabber)	2.5m	M1986A

**Set Combiner**

3-electrode	M1501A
5-electrode	M1502A

**Set Organizer**

**Shielded**

3-electrode	M1503A
5-electrode	M1504A

**Intra-Atrial** (Not Available in the U.S.A.)

Selector trunk cable	15214A
electrode set	15215A
ALPHACARD sterile connection cable to cava catheters.	

**Bedsheet Clip**

M1509A

---

## SpO<sub>2</sub> Accessories

### Philips Reusable Transducers

Adult finger	2.0m	M1191A
Adult ear clip	1.5m	M1194A
Pediatric finger	1.5m	M1192A
Infant finger	1.5m	M1195A
Neonatal foot/hand	1.5m	M1193A
Extension cable	2m	M1941A

### Disposable Transducers

	NellcorPB <sup>®</sup>	Philips order no. <sup>a</sup>	NellcorPB <sup>®</sup>	
	OxiMax		OxiCliq <sup>b</sup>	Oxysensor II
Adult	MAX-A	M1904B	A	D-25
Pediatric	MAX-P	M1903B	P	D-20
Infant	MAX-I	M1902B	I	I-20
Neonatal	MAX-N	M1901B	N	N-25

a. Philips Disposable Transducers are not available in the U.S.A

b. OxiCliq transducers and adapter cables must be purchased directly from NellcorPB<sup>®</sup>

Adapter Cable	1.1m	M1943A
Adapter Cable for OxiCliq transducers	0.9m	OC-3

---



---

### Warning

**M1901B, M1902B, N-25, I-20, OxiCliq N and OxiCliq I transducers contain natural rubber latex which may cause allergic reactions.**

---



---

**Materials Used for Philips SpO<sub>2</sub> Reusable Transducers**

	<b>Housing</b>	<b>Cable</b>
M1191A	silicone	silicone
M1192A	silicone	polyurethane
M1193A	silicone	polyurethane
M1194A	polyurethane	polyurethane
M1195A	silicone	polyurethane



## NBP Accessories



These cuffs and tubings are designed to have special protection against electric shocks (particularly regarding allowable leakage currents), and are defibrillator proof.

### Adult/Pediatric Multi-Patient Comfort Cuffs and Disposable Cuffs

Patient Category	Limb Circumference	Bladder Width	Disposable cuff Part No.	Reusable cuff Part No.	Tubing
Adult (Thigh)	42 to 54 cm	20 cm	M1879A	M1576A	<b>M1598B</b> (1.5m) or <b>M1599B</b> (3m)
Large Adult	34 to 43 cm	16 cm	M1878A	M1575A	
Adult	27 to 35 cm	13 cm	M1877A	M1574A	
Small Adult	20.5 to 28 cm	10.5 cm	M1876A	M1573A	
Pediatric	14 to 21.5 cm	8 cm	M1875A	M1572A	
Infant	10 to 15 cm	5.5 cm	M1874A	M1571A	

### Reusable Cuff Kits

Cuff Kits	Part No.
Infant, pediatric, small adult, adult	M1577A
Small adult, adult, large adult, thigh	M1578A
Infant, pediatric, small adult, adult, large adult, thigh	M1579A

### Adult/Pediatric Soft Single Patient Cuffs

Patient Category	Limb Circumference	Bladder Width	Disposable cuff Part No.	Tubing
Adult (Thigh)	45-56.5 cm	21.0 cm	M4579A	M1598B (1.5m) or M1599B (3m)
Large Adult	35.5-46 cm	17.0 cm	M4577A	
Adult	27.5-36.5 cm	13.5 cm	M4575A	
Small Adult	20.5-28.5 cm	10.6 cm	M4574A	
Pediatric	15.0-21.5 cm	8.0 cm	M4573A	
Infant	9-15 cm	5.4 cm	M4572A	

**Adult/Pediatric Antimicrobial Coated Reusable cuffs**

<b>Single-Hose Product</b>	<b>Cuff Size (color)</b>	<b>Circumference (cm)</b>	<b>Bladder Width</b>	<b>Tubing</b>
<b>M4552A</b>	Infant (orange)	9 - 14.8	5.4 cm 2.1 inches	M1598B (1.5m) or M1599B (3m)
<b>M4553A</b>	Pediatric (green)	13.8 - 21.5	8.0 cm 3.1 inches	
<b>M4554A</b>	Small Adult (royal blue)	20.5 - 28.5	10.6 cm 4.2 inches	
<b>M4555A</b>	Adult (navy blue)	27.5 - 36.5	13.5 cm 5.3 inches	
<b>M4557A</b>	Large Adult (burgundy)	35.5 - 46.0	17.0 cm 6.7 inches	
<b>M4559A</b>	Thigh (grey)	45 - 56.5	21.0 cm 8.3 inches	

**Neonatal/Infant Cuffs (Disposable, non-sterile)**

<b>Cuffs</b>	<b>Limb Circumference</b>	<b>Bladder Width</b>	<b>Part No.</b>	<b>Tubing</b>
Size 1	3.1 to 5.7 cm	2.2 cm	<b>M1866A</b>	M1596B (1.5m) or M1597B (3m)
Size 2	4.3 to 8.0 cm	2.8 cm	<b>M1868A</b>	
Size 3	5.8 to 10.9 cm	3.9 cm	<b>M1870A</b>	
Size 4	7.1 to 13.1 cm	4.7 cm	<b>M1872A</b>	

## PRESS Accessories



These transducers and accessories are designed to have special protection against electric shocks (particularly regarding allowable leakage currents), and are defibrillator proof.

### Pressure Transducer

Pressure Transducer	3.0m Cable	CPJ840J6
Disposable domes (pack of 50)		CPJ84022
Transducer holder (pack of 4)		CPJ84046
IV pole mount		CPJ84447

### Disposable Pressure Transducers

(Not Available in the U.S.A., Japan, Czech Republic and Canada)

Single Channel Kit		M1567A
Dual Channel Kit		M1568A
Transducer holder		M2271A
IV Pole Mount		M2272C
Adapter Cable	3.0m	M1634A

### Accessories for 1290C Pressure Transducers

Disposable domes (pack of 20)	1295CK-020
Disposable domes (pack of 60)	1295CK
Disposable dome kit	M1551B
Holder for 2 transducers	1292C
Holder for 3 transducers	1293C

### PULSION PiCCO Monitoring Kits

(Order directly from Pulsion Medical Systems)

PiCCO Monitoring Kit (30 cm pressure line, injectate temperature housing PV4046)	PV8103
PiCCO Monitoring Kit (150 cm pressure line, injectate temperature housing PV4046)	PV8115
PiCCO Monitoring Kit (150 cm pressure line,	

## Mainstream CO<sub>2</sub> Accessories

120 cm central venous pressure line injectate temperature housing PV4046	PV8115CVP
Adapter Cable 3.0 m/9.8' (also included in M1012A #K06)	PMK206

---

## Mainstream CO<sub>2</sub> Accessories

CO <sub>2</sub> Transducer Sensor	M1460A
Standard Airway Adapter (adult, reusable)	M1465A
Small Airway Adapter (pediatric, reusable)	14363A

## Microstream<sup>1</sup> CO<sub>2</sub> Accessories (Sidestream)

*Note*—A FilterLine ‘Set’ is a combination of a FilterLine sample tube with an airway adapter.

‘H’ in the accessory name denotes suitability for humidified ventilation.

A “Smart CapnoLine” is a combined oral-nasal FilterLine.

A “Smart CapnoLine O<sub>2</sub>” is a combined oral-nasal-O<sub>2</sub>-CO<sub>2</sub> FilterLine, able to provide supplemental oxygen to the patient.

An “NIV Line” is a nasal FilterLine especially suited for mask ventilation.

Ventilation	Environment	Patient	Accessories	Part No.
Intubated	Non-Humidified	>= 2 kg	FilterLine Set Adult/Pediatric	<b>M1920A</b>
		< 2 kg	FilterLine H Set Infant/Neonatal	<b>M1923A</b>
	Humidified	>= 2 kg	FilterLine H Set Adult/Pediatric	<b>M1921A</b>
		< 2 kg	FilterLine H Set Infant/Neonatal	<b>M1923A</b>
Non-Intubated, Single Purpose	Nasal CO <sub>2</sub> Up to 24 hours	> 45 kg	CapnoLine H Adult	<b>M4689A</b>
		10-45 kg	CapnoLine H Intermediate	<b>M4690A</b>
		< 10 kg	CapnoLine H Infant/Neonatal	<b>M4691A</b>
	Oral-Nasal CO <sub>2</sub> Up to 12 hours	> 55 kg	Smart CapnoLine Adult	<b>M2526A</b>
		20-55 kg	Smart CapnoLine Intermediate	<b>M2525A</b>
		10-20 kg	Smart CapnoLine Pediatric	<b>M2524A</b>
Non-Intubated, Dual Purpose	Nasal CO <sub>2</sub> + O <sub>2</sub> Up to 24 hours	> 45 kg	CapnoLine H O <sub>2</sub> Adult	<b>M4680A</b>
		10-45 kg	CapnoLine H O <sub>2</sub> Pediatric	<b>M4681A</b>
	Oral-Nasal CO <sub>2</sub> + O <sub>2</sub> Up to 12 hours	> 55 kg	Smart CapnoLine O <sub>2</sub> Adult	<b>M2522A</b>
		20-55 kg	Smart CapnoLine O <sub>2</sub> Intermediate	<b>M2521A</b>
		10-20 kg	Smart CapnoLine O <sub>2</sub> Pediatric	<b>M2520A</b>
		Mask, Single Purpose	C-PAP CO <sub>2</sub> Up to 12 hours	> 45 kg
10-45 kg	NIV Line Intermediate			<b>M4687A</b>

1. The following are trademarks of Oridion Medical Inc.: “Microstream”, “FilterLine”, “Smart CapnoLine”, and “NIV Line”.

## TEMP Accessories

### Reusable Temperature Probes

General Purpose Probe	21075A
Small Flexible Vinyl Probe (Infant/Pediatric)	21076A
Attachable Surface Probe	21078A

### Disposable Temperature Probes

General Purpose Probe	M1837A	
Skin Probe	21091A	
Esophageal/Stethoscope Probe	21093A	
	21094A	
	21095A	
Foley Catheter Probe	M2255A	
	21096A	
	21097A	
Adapter Cable	1.5m	21082B
	3.0m	21082A

---

## Monitor Mounting Options

Table Top Mount	M3080A	option A10
Universal Bed Hanger	M3080A	option A11 <i>(includes table top mount)</i>
Transport Bed Hanger	M3080A	option A21
Roller Top Stand	M3080A	option A22
Wall Rail	M3080A	option A13
Tilt/Swivel Wall Mount	M3080A	option A14 <i>(includes wall rail)</i>
GCX Wall Channel	M3080A	option A15
Universal Pole Mount Clamp	M3080A	option C05
Measurement Server Extension		
Mounting Clamp for transport	M3080A	option C06
Monitor Rail Mount	M3080A	option C10

---

## Monitor Accessory Options

Monitor Carrying Case	M3080A	option C12
Battery Charger for use with PowerSmart-compatible batteries. [Original Equipment Manufacturer Product Number: DR36-SMB-TNT]	M3080A	option C30
12V Adapter for use with a vehicle 12V power supply (for CE countries only) [Original Equipment Manufacturer Product Number: NotePower 75/Notepower 75i]	M3080A	option C32
Spare battery	M3080A	option C40

---

## Server Mounting Options

Server Mounting Plate (pack of five plates)	M3080A	option A01
Rotating Clamp Mount	M3080A	option A02

---

## Recorder

GSI Lumonics XE-50p	M3080A	option H20
---------------------	--------	------------

---

## Recorder Mounting Options

Roller Stand	M3080A	option A30
Wall Mount	M3080A	option A31

---

## Recorder Paper

For GSI Lumonics XE-50p:

10 rolls	M4816A
80 rolls	M4817A



## Symbols

<< SmartKey, 40

## Numerics

I lead (ECG), 140

II lead (ECG), 140

III lead (ECG), 140

3-electrode placement (ECG)

MCL1, 128

standard, 127

3-electrode placement (RESP), 180

V electrode placement (ECG), 125

V lead (ECG), 140

V1 lead (ECG), 140

V2 lead (ECG), 140

V3 lead (ECG), 140

V4 lead (ECG), 140

V5 lead (ECG), 140

V6 lead (ECG), 140

5-electrode placement (ECG), 125

5-electrode placement (RESP), 179

## A

ABP (PRESS), 206

See also PRESS

\*\*\* ABP DISCONNECT message, 61

\*\* ABP HIGH message, 61

\*\* ABP LOW message, 61

AC Power

connector, 30

LED, 30

operating frequency, 395

operating voltage, 395

specifications (monitor), 395

accessories

NBP

adult cuffs, 432

comfort cuffs, 431

disposable cuffs, 431

multi-patient comfort cuff kits, 431

neonatal/infant cuffs  
(disposable), 433

reusable cuffs, 431

single-hose disposable cuffs, 432

Active Ch. (ECG), 354

Add. Info (patient), 95

additional information (patient), 95

adjustments, 5

Admit Patient, 95

Admit/Discharge... (patient), 94, 97

Adult (patient category), 96

alarm

apnea delay (RESP), 185, 405, 417

asystole threshold, 162

configuring, 369

desat, 64

desaturation delay, 360

lamp, 52

latching behaviour, 370

limit, 36

changing, 46, 58

checking, 46, 58

CO<sub>2</sub>, 252, 264, 265

heart rate, 134, 401

highlighted, 52

NBP, 198

PRESS, 206, 240

RESP, 184

SpO<sub>2</sub>, 231, 406

TEMP, 242, 412

message, 36

other monitor, 116

over network, 116

patient, 61

technical, 76

missed beat, 66

patient, 52

pause threshold, 357

red, 52

reminder

configuring, 371

resetting, 57

silencing, 57

sound

configuring, 374

suspend

automatic activation, 372

blinking numerics, 371

duration, 369

reminder, 370

suspended symbol, 57

suspending, 57

technical, 53

volume

changing, 59

yellow, 52

Alarm Volume SmartKey, 47, 59

alarms

bed to bed, 116

chaining, 155

multiple, 155

priorities, 156

timeout periods, 154

Alarms Susp (alarm suspension  
time), 369

Alarms, configuring, 369

altitude

operating

measurement server, 399, 413

monitor, 395

storage

measurement server, 399, 413

monitor, 395

Always Reset to Defaults (patient  
transfer), 367

analog ECG signal, 322

anesthetics

operation in presence of  
flammable, 321

Ao (PRESS), 206

See also PRESS

\*\*\* Ao DISCONNECT message, 62

\*\* Ao HIGH message, 62

\*\* Ao LOW message, 63

\*\*\* APNEA message, 61

apnea (RESP)

detecting, 183

apnea alarm delay (RESP), 185, 405,  
417

arrhythmia alarms

M3150A, 150

M3153A, 149

yellow timeout periods, 154

arrhythmia analysis

ensuring accurate, 151

example of good ECG for, 141, 153

single-/multi-lead, 160

Arrhythmia analysis, configuring, 357

arrhythmia relearning

with EASI INOP, 130, 161

ART (PRESS), 206

See also PRESS

\*\*\* ART DISCONNECT message, 62

\*\* ART HIGH message, 62

\*\* ART LOW message, 62

artifact suppression, 211, 363

assembly, 5  
\*\*\* ASYSTOLE message, 63  
asystole threshold, 144, 403  
AudVis latching (alarm), 370  
Auto Filter (ECG), 354  
Auto/Man (RESP), 182  
automatic NBP  
  repeat time, 194  
  starting, 193, 194  
  stopping, 193, 194  
AutoSuspend, 372  
aVF lead (ECG), 140  
aVL lead (ECG), 140  
aVR lead (ECG), 140

## B

backlight  
  maintenance interval, 303  
basic operation, 38  
Battery, 312  
battery, 311, 397  
  charge time, 397  
  compartment, 30  
  discharge time, 397  
  empty INOP, 77  
  LED, 30  
  weight, 397  
Battery (LED), 311  
Battery Level Low message, 333  
beat labels  
  learning, 152  
bed label, 367  
bed to bed  
  alarms, 116  
  Information Center, 119  
  overview, 115  
  patient information, 117  
  unit, 118  
bezel protector, 341  
blinking numeric (alarm), 52  
blood pressure  
  changes (effect on NBP), 189  
blood pressure. See also NBP (non-invasive) or PRESS (invasive)  
blood vessels  
  occlude, 195  
Brady Clamp, 355  
\*\*\* BRADY LOW message, 64  
bradycardia, 355  
brain examination, 320  
breathing depth (RESP), 182

Brightness SmartKey, 47

## C

cabinet grounding, 319  
cabinet installation, 321  
Cal. Factor (PRESS), 214  
Cal. Press (PRESS), 217  
Care Group  
  alarms, 116  
  patient information, 117  
  viewing status, 115  
care group  
  assigning, 113  
  status, 115  
Cascading, 144  
cellular phones, 30  
Centigrade (TEMP units), 364  
chaining, 155  
chains, 157  
changing alarm limit, 46, 58  
Channel (ECG), 139  
Check Status Log message, 333  
checking alarm limit, 46, 58  
cleaning interval, 302  
clearance, 321  
clock, 398  
CO<sub>2</sub>  
  preparation, 247, 259  
  setup, 249, 262  
CO<sub>2</sub> EQUIP MALF message, 254, 266  
CO<sub>2</sub> NOISY SIGNAL message, 254, 267  
CO<sub>2</sub> On/Off, 249, 262  
color  
  ECG, 355  
  NBP, 361  
  PRESS, 363  
  RESP, 359  
  SpO<sub>2</sub>, 360  
  TEMP, 364, 365  
combining equipment, 320  
condensation, 321  
Configuration, 345  
Configuration Mode, 346  
connecting measurement server, 327  
connector  
  AC Power, 30  
  ECG output, 396  
  marker input, 397  
  measurement, 32, 33  
  measurement server, 31, 32, 33

nurse call, 31  
  Quick Link, 31, 32, 33  
  software update, 31  
  transducer, 32, 33  
Continue Module (measurement module transfer), 100, 102  
Continue Monitor (measurement module transfer), 100, 102  
corrosive gases, 321  
CPAP (RESP), 182  
crossed bell, 57  
cuff (NBP)  
  cleaning disposable, 289  
  pressure (NBP), 196  
  size for NBP, 189  
  sterilizing reusable, 290  
  tightness for NBP, 191  
  washing reusable, 290  
CUFF NOT DEFLATED message (NBP), 200  
CVP (PRESS), 206  
  See also PRESS  
  \*\* CVP HIGH message, 63  
  \*\* CVP LOW message, 64

## D

damage  
  mechanical, 37  
data  
  retention, 398  
date  
  setting, 48  
Date, Time, 48  
Default Sets, 48  
default setting, 36, 97  
  recalling, 97  
Defaults SmartKey, 97  
Defib Data In, 322  
defib synch, 30  
defibrillation protection, 318  
defibrillator, 322  
defibrillator synch  
  maintenance interval, 302  
Delete Event softkey, 277  
Delete List softkey, 277  
Delete List softkey (event), 276  
depth of breathing (RESP), 182  
desat alarm, 64  
detecting RESP, 183  
display, 396  
  resolution, 396

- setting up (waves, etc.), 44
- disposable TEMP probe
  - connecting, 238
- disposable transducer (SpO<sub>2</sub>), 224
- disposal, 343
- dyshemoglobins
  - intravascular (SpO<sub>2</sub>), 222

## E

- early systolic blood pressure(NBP), 196
- earthing, 319
- EASI, 124, 144
  - choosing, 135
  - ECG monitoring, 129
  - lead placement, 129
- ECG
  - . See also heart rate
  - accuracy, 401
  - bradycardia, 355
  - cable
    - operating room, 131, 178
    - orange, 131, 178
    - surgical, 131, 178
  - channels
    - active, 354
    - maximum, 354
  - choosing electrode sites, 124
  - color, 355
  - data out, 322
  - filter, 142
    - fixed configuration, 354
  - input impedance, 400
  - leads, 124
  - output connector, 396
  - range, 401
  - resolution, 401, 402, 403, 404
  - sensitivity, 401
  - Setup, 131
  - signal
    - analog, 322
  - specifications, 400
  - tachycardia, 355
  - wave
    - cascading, 144
    - size, 142
    - sizing all waves, 142
    - speed, 143
    - unfiltered, 143
  - wave label, 143
- ECG EQUIP MALF message, 145, 333

- ECG leads monitored, 124
- ECG On/Off, 132, 159
- ECG waves
  - examples of good, 141, 153
  - learning, 152
  - optimizing for arrhythmia analysis, 151
- ECG, configuring, 354
- ectopic status messages, 167
- electrical specification
  - monitor, 395
- Electrocardiogram. See ECG
- electrode
  - placement
    - paced patients (ECG), 129
    - surgical patients (ECG), 131
    - placement (ECG), 123, 125–131
    - placement (RESP), 179–180
  - electrosurgery protection, 318
  - electrosurgical interference
    - on ECG wave, 143
  - environmental specifications
    - measurement server, 399, 413
    - monitor, 395
  - equipment
    - combining, 320
  - equipotential grounding post, 30, 320
  - event
    - automatic storing, 373
    - content, 274
    - deleting, 276, 277
    - printing, 277
    - reviewing, 275
    - storing, 274
  - event numerics
    - reviewing, 276
- Event Trigger, 373
- event wave
  - reviewing, 276
- Events, configuring, 373
- explosive gases, 321
- extensions, 5
- ExtrBrady, 355
- ExtrTachy, 355

## F

- Fahrenheit (TEMP units), 364
- FCC compliance, 5
- Filter (ECG), 142
- floating inputs (Type CF), 318
- frequency

- operating (ac power), monitor, 395
- function key. See SmartKey
- functional test, 303

## G

- gases
  - explosive, 321
- General settings, configuring, 352
- grounding, 319
  - cabinet, 319
  - equipotential post, 320
- grounding post, 30

## H

- heart examination, 320
- heart rate extremes (effect on NBP), 189
- heart rate numeric
  - source, 132
- heart rate. See also ECG
- heart-lung machine
  - (effect on NBP), 189
- highlight, 39
- Hosp. Label, 368
- hospital label, 368
- HR from (heart rate source), 132
- \*\* HR HIGH message, 64, 69
- \*\* HR LOW message, 65, 69
- humidity
  - operating
    - measurement server, 399, 413
    - monitor, 395
  - storage
    - measurement server, 399, 413
    - monitor, 395

## I

- I lead (ECG), 140
- ICP (PRESS), 206
  - . See also PRESS
  - \*\* ICP HIGH message, 65, 66
  - \*\* ICP LOW message, 65
- ID code (patient), 95
- II lead (ECG), 140
- III lead (ECG), 140
- IMV (RESP), 182
- Information Center
  - bed to bed, 119
- inop, 76
  - . See also technical alarm

- input impedance
  - ECG, 400
- inputs
  - floating, 318
- inspection
  - interval, 302
- installation, 5, 325
  - cabinet, 321
- Intended Use, 5
- interference on wave (ECG), 122
- intermittent fault, tracking, 307
- intermittent mandatory ventilation (RESP), 182
- intra-aortic balloon pump, 322
- intravascular dyshemoglobins (SpO<sub>2</sub>), 222
- invasive blood pressure. See PRESS
- \*\* IRREGULAR HR message, 66

## K

- kPa (NBP units), 361
- kPa (PRESS units), 363

## L

- label
  - bed, 367
  - hospital, 368
  - monitor, 368
  - numeric, 36
  - PRESS, 206
  - TEMP, 240
  - wave, 36
- Label (PRESS), 206
- Label (TEMP), 240
- lamp
  - alarm suspended, 57
- LAP (PRESS), 206
  - See also PRESS
- \*\* LAP LOW message, 66
- Last Name (patient), 95
- Latching
  - alarm behaviour, 370
- lead aVF (ECG), 140
- lead aVL (ECG), 140
- lead aVR (ECG), 140
- lead I (ECG), 140
- lead II (ECG), 140
- lead III (ECG), 140
- lead MCL (ECG), 140
- lead V (ECG), 140
- lead V1 (ECG), 140

- lead V2 (ECG), 140
- lead V3 (ECG), 140
- lead V4 (ECG), 140
- lead V5 (ECG), 140
- lead V6 (ECG), 140
- leads monitored (ECG), 124
- LEADS OFF message (ECG), 145
- LEADS OFF XX message (ECG), 144, 168
- leakage current
  - patient, 318
- learning
  - initiating, 152
- LED
  - AC Power, 30
  - battery, 30, 311
- long report configuration (trend), 379
- long term trend, 272
- Long Trends softkey, 272

## M

- Main Screen button, 30, 39
- maintenance, 302, 304
- marker input connector, 397
- marker pulse (ECG), 322
- MCL lead (ECG), 140
- Mean Only (PRESS), 363
- measurement
  - preparation, 36
- measurement connector, 32, 33
- measurement method reference, 361
- measurement server
  - attaching, 98
  - connecting, 327
  - connector, 31, 32, 33
  - mounting, 31
  - size, 399
  - transferring, 98
  - weight, 399
- mechanical damage, 37
- Merc. Cal (PRESS transducer), 363
- messages
  - ectopic status, 167
  - rhythm status, 165
- methemoglobin (SpO<sub>2</sub>), 222
- missed beat, 66
- \*\* MISSED BEATS message, 69
- mmHg (NBP units), 361
- mmHg (PRESS units), 363
- modifications, 5
- monitor

- size, 394
- weight, 394
- Monitor (ECG filter), 143
- monitor label, 368
- Monitor Lbl, 368
- monitoring
  - preparation, 36
- mounting
  - measurement server, 31
  - monitor, 31
- MR imaging and the SpO<sub>2</sub> transducer, 222
- \*\* MULTIFORM PVC message, 66

## N

- NBP
  - adult cuffs, 432
  - calibration interval, 303
  - certification interval, 303
  - color, 361
  - comfort cuff kits, 431
  - comfort cuffs, 431
  - cuff
    - cleaning disposable, 289
    - pressure, 196
    - sterilizing reusable, 290
    - washing reusable, 290
  - cuff size, 189
  - cuff tightness, 191
  - disposable cuffs, 431
  - factors affecting, 189
  - limitations, 189
  - neonatal cuffs (disposable), 433
  - numeric, 196
  - pediatric cuffs, 432
  - repeat time, 196
  - repeat time for automatic, 194
  - reusable cuffs, 431
  - setup, 197
  - single-hose disposable cuffs, 432
  - site
    - inspection, 188, 192
    - specification, 408
  - start/stop button, 32, 33
  - starting, 192
  - starting automatic, 193, 194
  - stopping, 192
  - stopping automatic, 193, 194
  - time of last measurement, 196
  - units, 196, 361
- NBP CUFF OVERPRESS message, 200

NBP EQUIP MALF message, 201  
 \*\* NBP HIGH message, 67  
 NBP INTERRUPTED message, 201  
 \*\* NBP LOW message, 67  
 NBP MEASURE FAILED message, 201  
 NBP On/Off, 197  
 NBP, configuring, 361  
 Neo (patient category), 96  
 network, 106  
   wireless, 106  
     interference, 107  
     performance, 107  
     range, 107  
     signal strength, 107  
 networked  
   wired, 106  
 new patient, 95  
 New Patient (measurement module transfer), 100, 102  
 Next Strip softkey (event), 276  
 non-invasive blood pressure. See NBP  
 \*\* NON-SUSTAIN VT message, 67  
 numeric, 36  
   blinking (alarm), 52  
   blinking during suspended alarm, 371  
   event, 276  
 numeric label, 36  
 nurse call, 57  
   conditions, 372  
   connector, 31

**O**

obesity (effect on NBP), 189  
 occlude blood vessels, 195  
 On-Off/Standby button, 30  
 operating altitude  
   measurement server, 399, 413  
   monitor, 395  
 operating frequency (ac power)  
   monitor, 395  
 operating humidity  
   measurement server, 399, 413  
   monitor, 395  
 Operating Room  
   configuration, 376  
 operating room ECG cable, 131, 178  
 operating temperature  
   measurement server, 399, 413  
   monitor, 395

operating voltage  
 monitor, 395  
 operation  
   basic, 38  
 options, 29  
 orange ECG cable, 131, 178  
 oxygen saturation of arterial blood. See SpO<sub>2</sub>

## P

P1 (PRESS), 206  
   See also PRESS  
 \*\*\* P1 DISCONNECT message, 67  
 \*\* P1 HIGH message, 67  
 \*\* P1 LOW message, 68  
 P1 NOISY SIGNAL message (PRESS), 219  
 P1 NON-PULSATILE message (PRESS), 219  
 pace pulse detection (ECG), 135  
 paced patients  
   electrode placement (ECG), 129  
   repolarization tails, 137  
   setting status, 135  
   warnings for, 135  
 \*\* PACER NOT CAPT message, 68  
 \*\* PACER NOT PACE message, 68  
 \*\* PAIR PVCS message, 68  
 PAP (PRESS), 206  
   See also PRESS  
 \*\*\* PAP DISCONNECT message, 68  
 \*\* PAP HIGH message, 69  
 \*\* PAP LOW message, 69  
 parameter  
   switching on or off, 45  
 parts and accessories, 6  
 patient  
   admit, 95  
   alarm, 52  
     message, 61  
   category, 95  
   category (NBP), 188  
   data, 94  
   identification, 95  
   information, 95  
     bed to bed, 117  
   leakage current, 318  
   movement (effect on NBP), 189  
   name, 36, 95  
   new, 95  
   paced, (ECG), 129  
   safety, 318

skin preparation  
   ECG, 122  
   RESP, 178  
   surgical, 131  
   transfer, 98  
     automatic, 366  
     settings, 367  
 Patient Selection Default (patient transfer), 366  
 Patient Size, 96  
   . See also patient category  
 pause alarm  
   threshold, 357  
 pause threshold, 403  
 Pedi (patient category), 96  
 performance, 5  
 performance specification  
   monitor, 396  
 performance test, 423  
 phones  
   portable, 30  
 physical specifications  
   measurement server, 399  
   monitor, 394  
 physiological alarm message. See alarm message  
   patient  
 placing electrodes (ECG), 123, 125–131  
 placing electrodes (RESP), 179–180  
 PLETH wave, 233  
   speed, 233  
 plethysmograph. See PLETH  
 portable phones, 30  
 preparing skin  
   for ECG, 122  
   for RESP, 178  
 PRESS  
   alarm  
     during zero, 207  
   artifact suppression, 211  
   color, 363  
   filter, 362  
   label, 206  
   measure mean only, 362  
   preparation, 204  
   setup, 209  
   specification, 410  
   transducer  
     calibration, 214, 363  
     calibration factor, 213

- cleaning, 292, 293
- last zero, 207
- mercury calibration, 215
- sterilizing, 293
- sterilizing (gas), 294
- when to zero, 207
- zero, 207
- transducers
  - input sensitivity, 204
  - selecting, 204
- units, 363
- wave, 210
  - optimum size, 210
  - size, 210
  - speed, 211
  - zero button, 32, 33
- PRESS On/Off, 209
- Press, configuring, 362
- Pressure Zero & Check Cal message, 333
- Print Event softkey, 277
- Print Page softkey (trend), 273
- Print Screen SmartKey, 46
- printer
  - connecting, 337
  - port, 30
  - selecting, 335
- printing
  - event, 277
  - trend data, 273
- Prompt Volume, 375
- protection class (IEC 601-1, class 1), 319
- protective earth, 319
- protective grounding, 319
- \*\* PVC HIGH message, 69

**Q**

- QRS
  - complex (ECG)
    - suppressed, 143
  - sound
    - configuring, 374
  - tone modulation (SpO<sub>2</sub>), 230
  - volume (ECG)
    - changing, 46, 47, 59, 133
- QRS Low, 374
- QRS Tick, 374
- QRS Tone, 374
- QRS Type, 374
- QRS Volume SmartKey, 46, 133
- Quick Link connector, 31, 32, 33

Quick Sets, 348

**R**

- R (nurse call), 372
- R/Y (nurse call), 372
- R/Y/I (nurse call), 372
- radio phones, 30
- RAP (PRESS), 206
  - See also PRESS
- \*\* RAP HIGH message, 70
- \*\*RAP LOW message, 70
- ReAlarm, 371
- realtime clock, 398
- record
  - events in, 276
- Record softkey (trend), 273
- recorder
  - connecting, 339
- recording. See printing
- red alarm, 52
- Relay Sens (nurse call conditions), 372
- reliability, 5
- Remind. Time (alarm), 371
- repairs, 5
- repolarization tails, 137
- resetting alarm, 57
- resolution (display), 396
- RESP
  - color, 359
  - detection, 182, 183
    - level, 183
  - rate close to heart rate, 182
  - setup, 181
  - wave
    - size, 184
    - speed, 184
- RESP EQUIP MALF message, 186, 333
- RESP ERRATIC message, 186
- RESP LEAD OFF message, 186
- Resp Speed, 184
- Respiration. See RESP
- retrolental fibroplasia (SpO<sub>2</sub>), 231
- reusable SpO<sub>2</sub> transducer, 224
- reusable TEMP probe
  - connecting, 238
- Review Event SmartKey, 275
- Review Events, 275
- rhythm status messages, 165
- \*\* R-ON-T PVCS message, 71
- \*\* RR HIGH message, 63, 70

- \*\* RR LOW message, 70
- RSS 210 Compliance, 5
- \*\* RUN PVCS HIGH message, 70

**S**

- safety, 5
  - maintenance interval, 302
  - monitor, 394
  - patient, 318
- safety test, 423
- Same Patient (measurement module transfer), 100, 102
- scale
  - ECG wave, 142
  - PRESS wave, 206, 210
  - PRESS wave, optimum, 210
  - RESP wave, 184
- screen brightness
  - changing, 47
  - select, 39
- setting
  - default, 36, 97
  - default, recalling, 97
  - retention, 398
- Setup button, 30, 39
- short report configuration (trend), 378
- short term trend, 272
- Short Trends softkey, 272
- Show Event softkey, 276
- Show Strip softkey (event), 276
- Silence/Reset button, 30, 32, 33, 38, 57
- silencing alarm, 57
- size
  - measurement server, 399
  - monitor, 394
- skin preparation
  - ECG, 122
  - RESP, 178
- SmartKey, 40
  - label, 36
  - using, 40
- softkey, 40
- softkey. See SmartKey
- software update
  - connector, 31
- Speed, 45
- SpO<sub>2</sub>
  - averaging time, 359
  - cable
    - handling, 222
  - color, 360

- high alarm delay, 360
  - low alarm delay, 359
  - preparation, 222
  - setup, 229
  - site
    - inspection, 226
    - selection, 224
  - specification, 406
  - tone modulation, 230
  - transducer
    - disposable, 224
    - handling, 222
    - lifetime, 222
    - reusable, 224
  - SpO<sub>2</sub> EQUIP MALF message, 234
  - SpO<sub>2</sub> ERRATIC message, 234
  - \*\* SpO<sub>2</sub> HIGH message, 71
  - SpO<sub>2</sub> LIGHT INTERF. message, 234
  - \*\* SpO<sub>2</sub> LOW message, 71
  - SpO<sub>2</sub> NOISY SIGNAL message, 235
  - SpO<sub>2</sub> NON-PULSATILE message, 235
  - SpO<sub>2</sub> On/Off, 230
  - SpO<sub>2</sub>, configuring, 359
  - ST
    - measurement, 171
    - viewing data, 171
  - Standby, 322
  - Start/Stop button, 32, 33
  - Status Log, 307
    - clearing, 307
    - monitor, 307
    - printing, 307
  - status messages, 165
    - ectopic, 167
    - rhythm, 165
  - \*\* STn HIGH message, 71
  - \*\* STn LOW message, 71
  - storage
    - altitude
      - measurement server, 399, 413
      - monitor, 395
    - humidity
      - measurement server, 399, 413
      - monitor, 395
    - temperature
      - measurement server, 399, 413
      - monitor, 395
  - Store Screen SmartKey, 274
  - surgical ECG cable, 131, 178
  - surgical patients
    - electrode placement (ECG), 131
  - Suspend button, 30, 39, 57
  - suspended alarm
    - blinking numerics, 371
    - duration, 369
    - lamp, 57
    - reminder, 370
  - suspending alarm, 57
  - SuspRemind, 370
  - SuspRemind (Suspend Reminder), 370
  - \*\* SVT message, 72
  - systolic blood pressure (NBP)
    - early, 196
- ## T
- T1 (TEMP), 240
    - . See also TEMP
  - \*\* T1 HIGH message, 72
  - \*\* T1 LOW message, 72
  - Table Trends, 272
  - Tachy Clamp, 355
  - \*\*\* TACHY HIGH message, 64
  - tachycardia, 355
  - Tart (TEMP), 240
    - . See also TEMP
  - \*\* Tart HIGH message, 72
  - \*\* Tart LOW message, 72
  - Tcore (TEMP), 240
    - . See also TEMP
  - \*\* Tcore HIGH message, 72
  - \*\* Tcore LOW message, 72
  - technical alarm, 57
    - inops, 53
  - technical alarm message, 76
  - telephones
    - portable, 30
  - TEMP
    - color, 364, 365
    - label, 240
    - preparation, 238
    - probe
      - connecting disposable, 238
      - connecting reusable, 238
    - setup, 239, 240
    - units, 375
  - TEMP EQUIP MALF message, 333
  - TEMP On/Off, 239, 241
  - temperature
    - operating
      - measurement server, 399, 413
      - monitor, 395
    - storage
      - measurement server, 399, 413
      - monitor, 395
  - temperature extremes (operating environment), 321
  - temperature. See TEMP
  - Tesop (TEMP), 240
    - . See also TEMP
  - \*\* Tesop HIGH message, 73
  - \*\* Tesop LOW message, 73
  - time, 36
    - setting, 48
  - timeout periods
    - clearing, 155
  - Tnaso (TEMP), 240
    - . See also TEMP
  - \*\* Tnaso HIGH message, 73
  - \*\* Tnaso LOW message, 73
  - Tone Mod (SpO<sub>2</sub>), 230
  - tone modulation (SpO<sub>2</sub>), 230
  - touchstrip, 30, 39
  - trace. See wave
  - transducer
    - PRESS, 204
  - transducer connector, 32, 33
  - transfer
    - patient, 98
      - centrally monitored, 98
      - to/from IntelliVue, 101
    - patient, automatic, 366
    - settings, 367
    - transport, 309
  - Trect (TEMP), 240
    - . See also TEMP
  - \*\* Trect HIGH message, 73
  - \*\* Trect LOW message, 73
  - trend, 272
    - long report configuration, 379
    - long term, 272
    - printing, 273
    - short report configuration, 378
    - short term, 272
    - specifications, 398
  - Trends SmartKey, 272
  - Tskin (TEMP), 240
    - . See also TEMP
  - \*\* Tskin HIGH message, 73
  - \*\* Tskin LOW message, 74
  - Tven (TEMP), 240
    - . See also TEMP
  - \*\* Tven HIGH message, 74
  - \*\* Tven LOW message, 74

## U

- UAP (PRESS), 206
  - See also PRESS
- \*\*\* UAP DISCONNECT message, 74
- \*\* UAP HIGH message, 74
- \*\* UAP LOW message, 74
- unit
  - bed to bed, 118
- units
  - NBP, 361
  - PRESS, 363
  - TEMP, 364, 375
- unpacking, 325
- users
  - intended, 7
- UVP (PRESS), 206
  - See also PRESS
- \*\* UVP HIGH message, 75
- \*\* UVP LOW message, 75

## V

- V electrode placement (ECG), 125
- V lead (ECG), 140
- V1 lead (ECG), 140
- V2 lead (ECG), 140
- V3 lead (ECG), 140
- V4 lead (ECG), 140
- V5 lead (ECG), 140
- V6 lead (ECG), 140
- venipuncture, 196

- \*\* VENT BIGEMINY message, 75
- \*\*\* VENT FIB/TACH message, 75
- \*\*\* VENT RHYTHM message, 75
- \*\* VENT TRIGEMINY message, 75
- vibration, 321
- Visual latching (alarm), 370
- voltage
  - operating, monitor, 395
- volume
  - alarm, 47, 59
  - QRS, 46, 47, 59, 133
- \*\*\* VTACH message, 76

## W

- wave, 36, 44
  - ECG cascading, 144
  - ECG unfiltered, 143
  - event, 276
  - interference (ECG), 122
  - label, 36
  - ECG, 143
- PLETH, 233
- PRESS, 210
- selecting, 44
- size
  - ECG, 142
  - PRESS, 210
  - PRESS optimum, 210
  - RESP, 184
- speed, 45
- ECG, 143

PLETH, 233

PRESS, 211

RESP, 184

waveform. See wave

waves

ECG examples, 141, 153

weight

battery, 397

measurement server, 399

monitor, 394

wireless network, 106

interference, 107

performance, 107

range, 107

signal strength, 107

## Y

- yellow alarm, 52
- yellow arrhythmia alarms
  - timeout periods, 154

## Z

- Zero button, 32, 33
- ZERO button (PRESS), 207
- zero PRESS transducer, 207
  - effect on alarm, 207
  - previous, 207
  - when, 207
- Zero SmartKey (PRESS), 207, 208