

RETURN TO THIS MANUAL'S TABLE OF CONTENTS
RETURN TO CD-ROM TABLE OF CONTENTS

Drägermedical

A Dräger and Siemens Company

Technical Service Manual

Part Number: 4117104
Rev: K
Date: 20 February 2004
© 2004 Draeger Medical, Inc.

**Fabius GS[®]
Anesthesia System**

[RETURN TO THIS MANUAL'S TABLE OF CONTENTS](#)
[RETURN TO CD-ROM TABLE OF CONTENTS](#)



A Dräger and Siemens Company

Fabius GS Service Manual Table of Contents

What's New in Rev. K

DESCRIPTION	PAGE
SECTION 1: INTRODUCTION	
1.0 Recommendations	1-1
SECTION 2: FUNCTION DESCRIPTION	
2.0 FUNCTION DESCRIPTION	2-1
2.1 General Information about the Fabius GS	2-1
2.2 Fabius GS Function Diagram	2-5
2.3 Battery Backup	2-7
2.4 Fabius GS Piping Diagram	2-8
2.5 Function Description of Gas Box	2-9
2.6 SORC (Sensitive Oxygen Ratio Controller)	2-11
2.7 Compact Breathing System, Cosy II	2-13
2.8 Ventilator	2-30
2.9 Pneumatic System	2-33
2.10 Electrical Block Diagram	2-35
2.11 Function Description: Control PCB	2-36
2.12 Control Panel Assembly	2-38
2.13 FiO2 Measurement	2-40
2.14 Respiratory Flow Measurement	2-41
2.15 Gas Flow Rate Measurement	2-42
2.16 Vaporizer	2-43
SECTION 3: TROUBLESHOOTING GUIDE	
3.0 TROUBLESHOOTING	3-1
3.1 Power Supply and Voltage Distribution	3-1
3.2 Battery	3-7
3.3 Troubleshooting Guides	3-7
SECTION 4: DIAGNOSTICS	
4.0 DIAGNOSTICS	4-1
4.1 System Service Screen	4-5
4.2 Main Service Screen	4-6
4.3 Service Log	4-7
4.4 Preventive Maintenance	4-17
4.5 General	4-19
4.6 Calibration	4-25
4.7 Configure	4-30
4.8 Serial Port	4-47

DESCRIPTION	PAGE
SECTION 5: REPLACEMENT PROCEDURES	
5.0 REPLACEMENT PROCEDURES	5-1
5.1 Cylinder Yokes and Regulators	5-2
5.2 Cylinder Pressure Gauges	5-5
5.3 Auxiliary Oxygen Flow Meter	5-7
5.4 Vaporizers	5-9
5.5 O2 Flush Valve	5-12
5.6 Caster	5-14
5.7 Ventilator	5-16
5.8 Gas Inlet Assembly (including O2 supply pressure switch)	5-27
5.9 Battery	5-29
5.10 Power Supply	5-31
5.11 Control PCB Assembly	5-33
5.12 Pneumatic (PEEP Control) Assembly	5-38
5.13 Flow Meter Bezel Assembly	5-43
5.14 Fresh Gas Flow Meter	5-45
5.15 Flow Control Valves	5-47
5.16 Fresh Gas Flow Sensors and Filter Assembly	5-49
5.17 Pipeline Pressure Gauges	5-51
5.18 SORC (Sensitive Oxygen Ratio Controller)	5-53
5.19 Fresh Gas Display PCB	5-55
5.20 Monitor Bezel Assembly	5-57
5.21 Spirolog Sensor and Cable	5-59
SECTION 6: ADJUSTMENT AND CALIBRATION PROCEDURES	
6.0 ADJUSTMENT AND CALIBRATION PROCEDURES	6-1
6.1 Cylinder Pressure Regulator Adjustment	6-1
6.2 Gas Inlet Regulator Output Adjustment	6-4
6.3 Oxygen Supply Pressure Alarm Switch Adjustment	6-6
6.4 Sensitive Oxygen Ratio Controller (SORC) Adjustment	6-8
6.5 Oxygen Sensor Calibration	6-11
6.6 Pressure Calibration	6-13
6.7 Fresh Gas Flow Calibration	6-14
6.8 PEEP Valve Calibration	6-15
6.9 Vacuum Adjustment	6-17
SECTION 7: PMS PROCEDURE	
7.0 PMS PROCEDURE, FABIUS GS	7-1
7.1 Electrical Safety	7-16
7.2 System Diagnostics	7-18
7.3 Battery Circuit	7-19
7.4 Configuration	7-19
7.5 Service Data	7-19
7.6 Calibrations	7-20
7.7 Site Configurations	7-20
7.8 Scavenger, AGS	7-24
7.9 Breathing System	7-25
7.10 Vapor Interlock System	7-39
7.11 Yokes & Gauges	7-40
7.12 Gas Inlet Regulator Output	7-42
7.13 Cylinder Regulator & Pipeline Gauges	7-46

DESCRIPTION	PAGE
SECTION 7: PMS PROCEDURE (Continued)	
7.14 High Pressure Leak	7-51
7.15 Oxygen Supply Failure Protection	7-53
7.16 Flowmeters	7-55
7.17 Oxygen Monitor	7-57
7.18 Oxygen Concentrations	7-59
7.19 SORC	7-60
7.20 Pressure Monitor	7-61
7.21 Ventilator	7-63
7.22 Volume Alarms	7-70
7.23 Audio Silence	7-72
7.24 Oxygen Flush Valve	7-73
7.25 Final Tests	7-74
SECTION 8: SOFTWARE UPDATE PROCEDURE	
8.0 SOFTWARE UPDATE PROCEDURE	8-1
8.1 REQUIREMENTS	8-1
8.2 Installing Send Image (utility) file on laptop. (If applicable)	8-1
8.3 Updating Send Image (utility) file	8-5
8.4 INSTALLING FABIUS GS SOFTWARE FROM A PC	8-5
8.5 Boot Strap Download Procedure	8-13
SECTION 9: SPARE AND REPLACEMENT PARTS	
9.0 Spare and Replacement Parts	9-1
Trolley assembly, O2 Flush Valve, Writing tray	9-3
Spirolog flow sensor, O2 sensor, Fresh gas hose	9-5
Breathing system assembly w/APL bypass	9-7
Breathing Arm Extension	9-9
COSY absorber top	9-11
COSY absorber canister	9-13
Breathing system mount assembly; Gauge assembly, patient airway pressure	9-15
Fresh Gas Flow Meter (part of flow meter bezel assembly)	9-17
Flow control valves & valve manifold (part of flow meter bezel assembly)	9-19
Fresh gas flow sensors & filter asm (part of flow meter bezel assembly) Applicable to Fabius GS Machines Serial Number 12191 and lower)	9-21
Fresh gas flow sensors & filter asm (part of flow meter bezel assembly) Applicable to Fabius GS Machines Serial Number 12191 and higher)	9-23
Pipeline pressure gauges (part of flow meter bezel assembly)	9-25
SORC (part of flow meter bezel assembly)	9-27
Fresh gas display PCB (part of flow meter bezel assembly)	9-29
Cylinder Yokes, Regulators, and Gauges:	9-31
Gas Inlet Assembly	9-33
Controller PCB and related parts (part of controller assembly P/N 4116400)	9-35
Pneumatic Assembly	9-37
Bezel Assembly, Monitor	9-39
Ventilator	9-41
Auxiliary O2 Flow Meter	9-43
Vapor mounting systems	9-45
Scavenger, AGS	9-47
AGS Scavenger kit w/adj valve	9-49

FABIUS GS ANESTHESIA SYSTEM

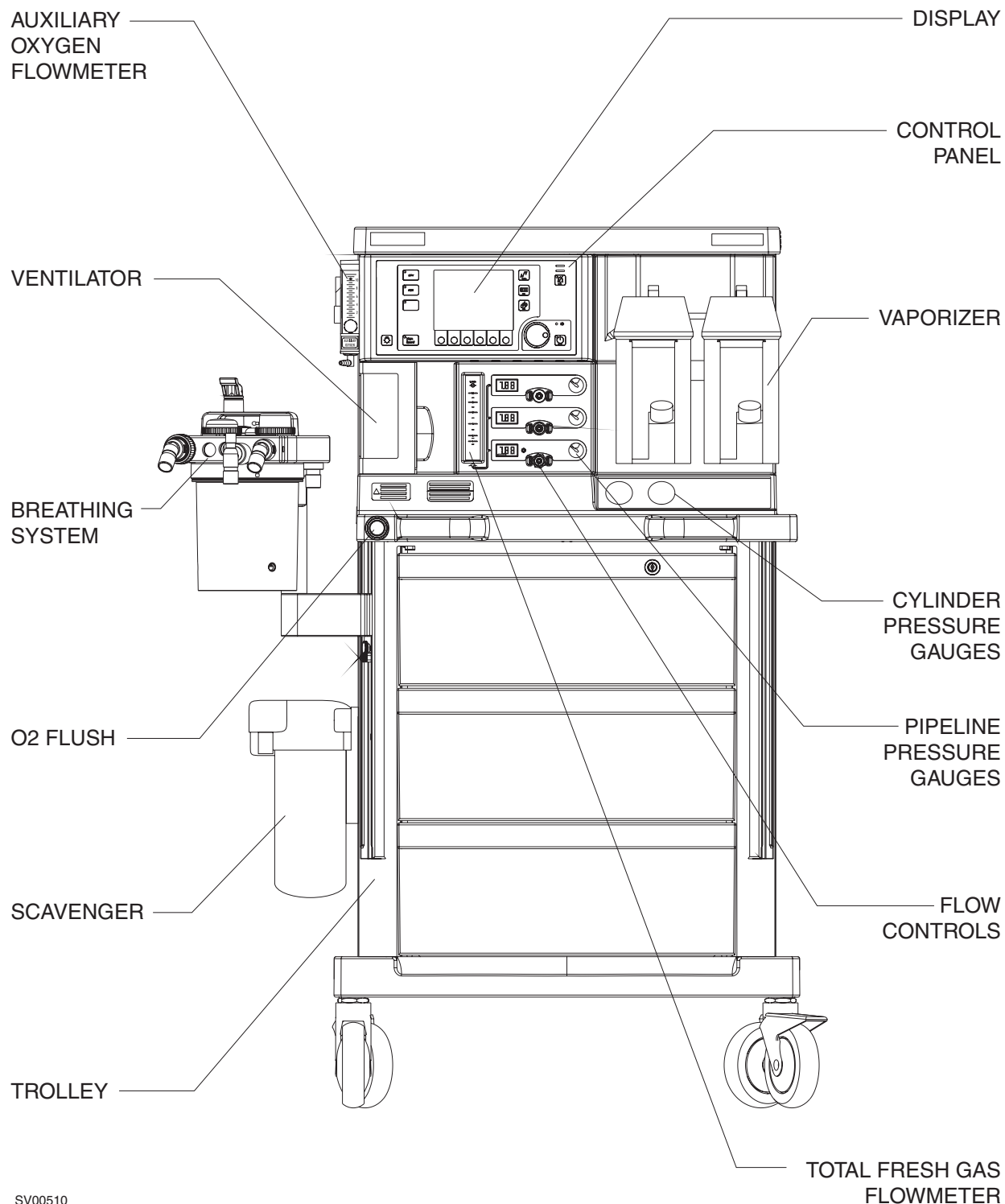

SV00510

1.0 Recommendations

Because of the sophisticated nature of Draeger Medical, Inc. anesthesia equipment and its critical importance in the operating room setting, it is highly recommended that only appropriately trained and experienced professionals be permitted to service and maintain this equipment. Please contact DrägerService® at (800) 543-5047 for service of this equipment in North America. For service in Europe call 49 (451) 882-4222. For service in other countries call (215) 721-5402.

Draeger Medical, Inc. recommends that the Fabius GS be serviced at six month intervals. Periodic Manufacturer’s Certification agreements are available for equipment manufactured by Draeger Medical, Inc. Please contact us for further information concerning these agreements.

Draeger Medical, Inc. products /material in need of factory repair shall be sent to:

For North America and other countries except Europe:	For service in Europe:
DrägerService® 3124 Commerce Drive Telford, PA 18969 U.S.A. (Include RMA Number)	Dräger Medical AG & Co. KGaA Moislinger Allee 53-55 Reparaturannahme 23542 Lübeck Germany

HOW TO USE THIS MANUAL

The manual is divided into several sections. The **DIAGNOSTICS** section describes self-test and service diagnostics for checking the system functions. An understanding of the on-board service capabilities is necessary before any attempt is made to troubleshoot the unit. The **TROUBLESHOOTING** section lists error codes and provides troubleshooting guides to assist the Technical Service Representative in locating the source of a problem. The **REPLACEMENT PROCEDURES** section contains instructions for removal and replacement of assemblies that are considered field-replaceable. The **ADJUSTMENT AND CALIBRATION PROCEDURES** section contains the field procedures needed to restore original system specifications. The **Periodic Manufacturer’s Service (PMS) PROCEDURE** section outlines the steps required to verify the electrical, mechanical and pneumatic safety of the unit and also identifies components requiring periodic replacement. The **SPARE PARTS** section is provided for use as a reference only to obtain part numbers and descriptions for parts and assemblies for replacement purposes. For items not shown in the spare parts section, contact DrägerService®.

GENERAL TROUBLESHOOTING GUIDELINES

Troubleshooting the Fabius GS should always begin by communicating with those who observed or experienced a problem with the unit. This may eliminate unnecessary troubleshooting steps. Once a general problem is identified, refer to the troubleshooting flow charts in Section 3 to determine the proper corrective action to be taken.

After any component is replaced, verify that the unit is operating properly by running the appropriate diagnostic procedure. The **PMS PROCEDURE** in Section 7 must also be performed after any component is replaced.

The general arrangement of the Fabius GS anesthesia system is shown on the opposite page.

WARNINGS

Warnings are used in this manual before procedures which if not performed correctly could result in personal injury.

CAUTIONS

Cautions are used in this manual to alert service personnel to the possibility of damage to the equipment if a procedure is not performed correctly.

See the *Fabius GS Operator's Instruction Manual* for:

- **Additional Warning and Caution statements**
- **Explanation of symbols**
- **Technical Specifications**

Copyright

Copyright© 2004 by Draeger Medical, Inc. All rights reserved. No part of this publication may be reproduced, transmitted, transcribed, or stored in a retrieval system in any form or by any means, electronic or mechanical, including photocopying and recording, without written permission of Draeger Medical, Inc.

Trademark Notices

Datagrip, DrägerService, ORM, Quality Service For Life, Respitone, Narkomed, Vigilance Audit, Vitalert, Vitalink, Narkomed GS, Fabius, and Fabius GS are registered trademarks of Draeger Medical, Inc. All other products or name brands are trademarks of their respective owners.

Disclaimer

The content of this manual is furnished for informational use only and is subject to change without notice. Draeger Medical, Inc. assumes no responsibility or liability for any errors or inaccuracies that may appear in this manual.

2.0 FUNCTION DESCRIPTION

2.1 General Information about the Fabius GS

The Fabius GS comprises the following assemblies:

- Bezel assembly: Display and Control Panel
- Flowmeter assembly
- Gas Box: Gas Inlet Assembly and related items
- Breathing system
- Pneumatic Assembly
- Ventilator
- Anesthetic vaporizer(s)
- Trolley

Monitoring, Electrical and Gas connections are illustrated on following pages.

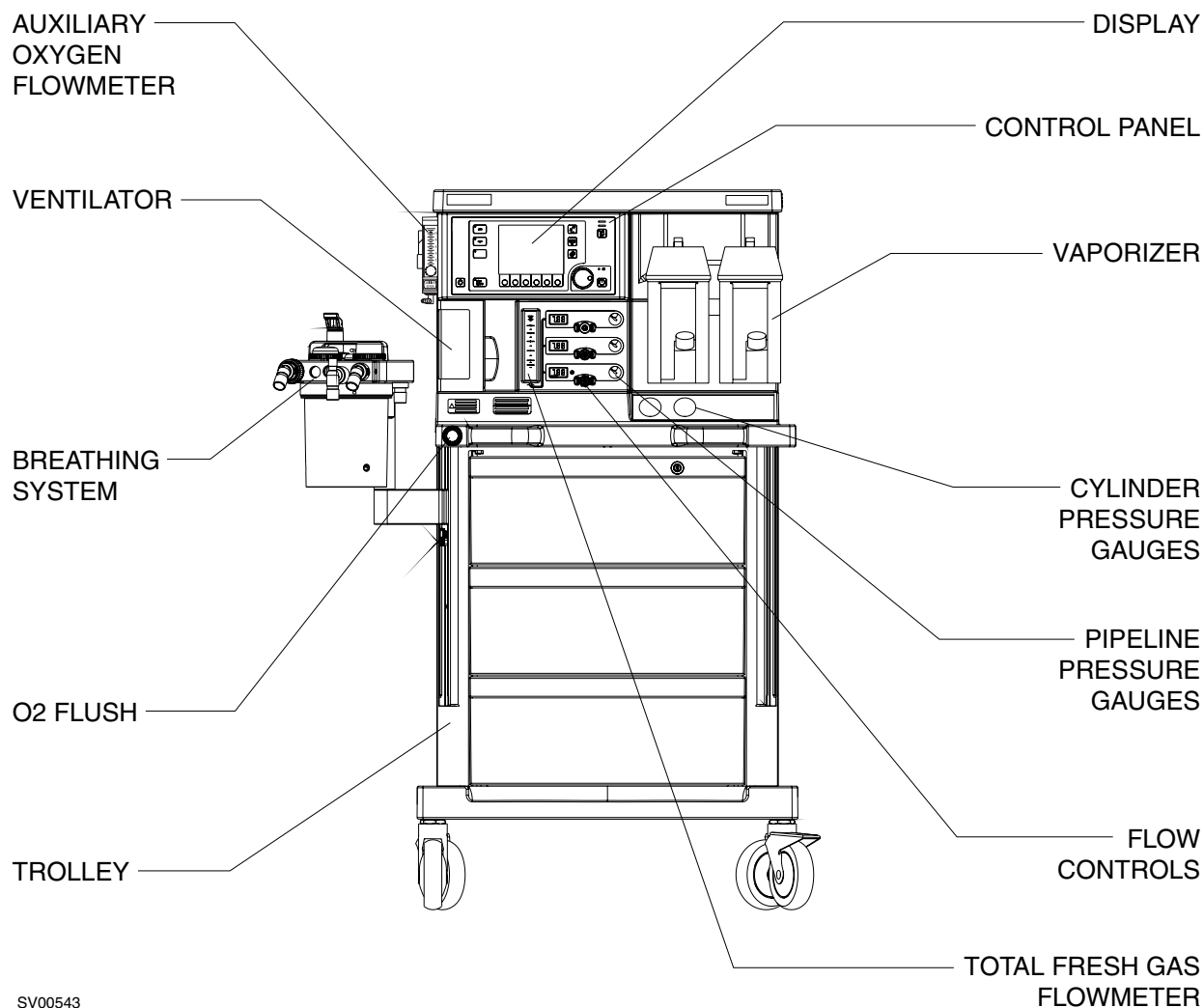

SV00543

Figure 2-1. Front View of Fabius GS Anesthesia System

SV00457

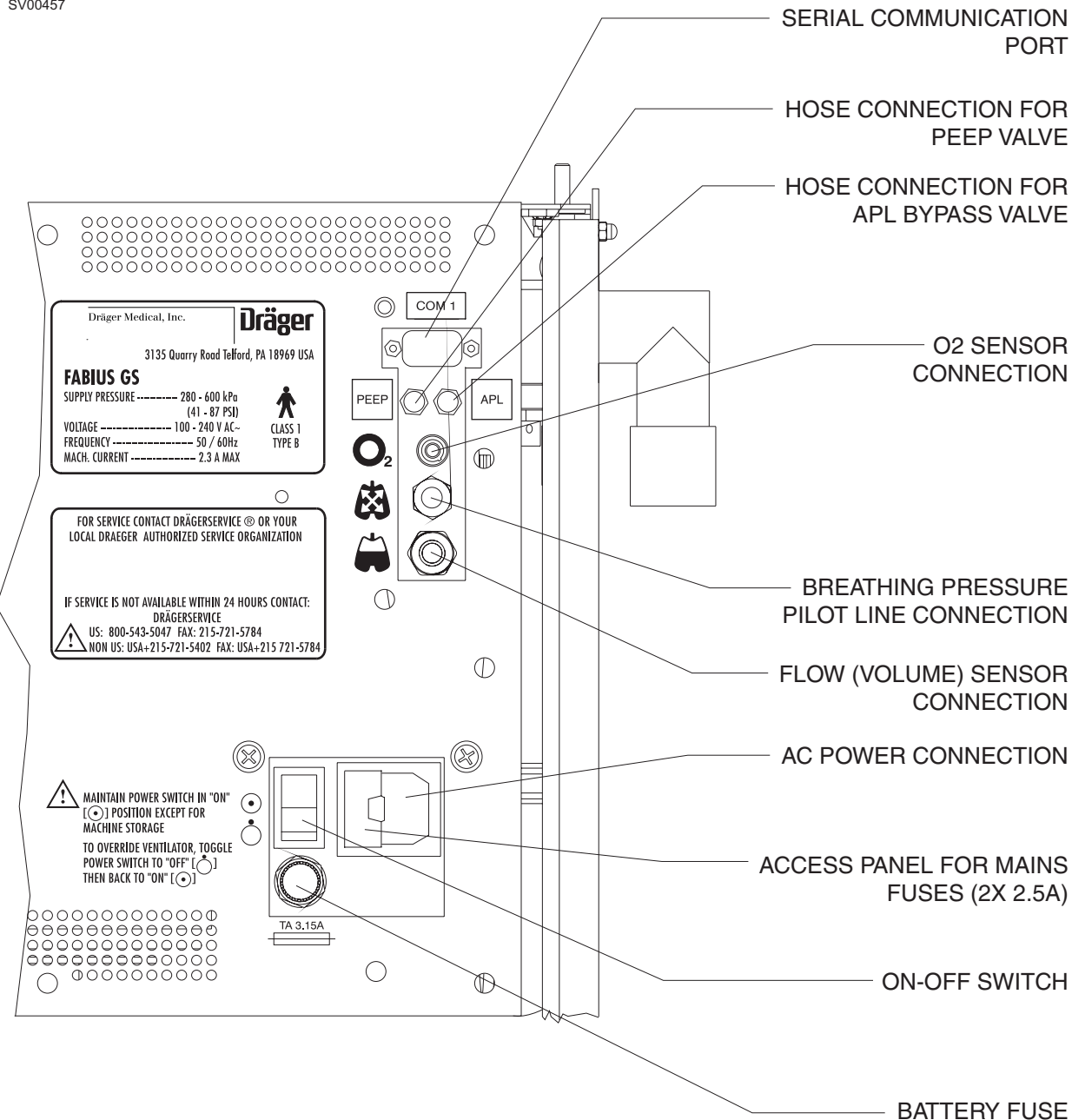

Figure 2-2. Back View Showing Interface Panel and Power Entry

SV00505

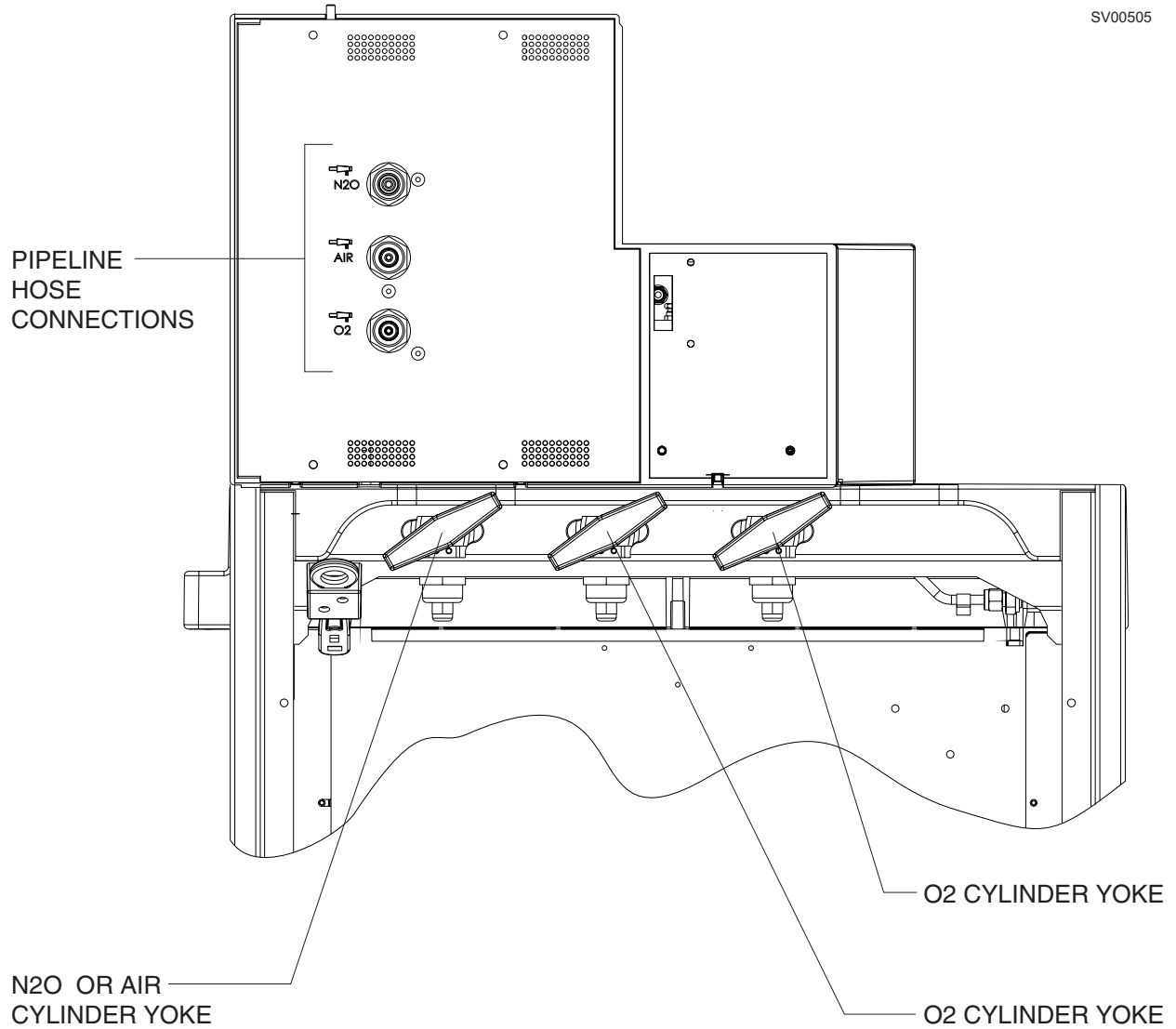
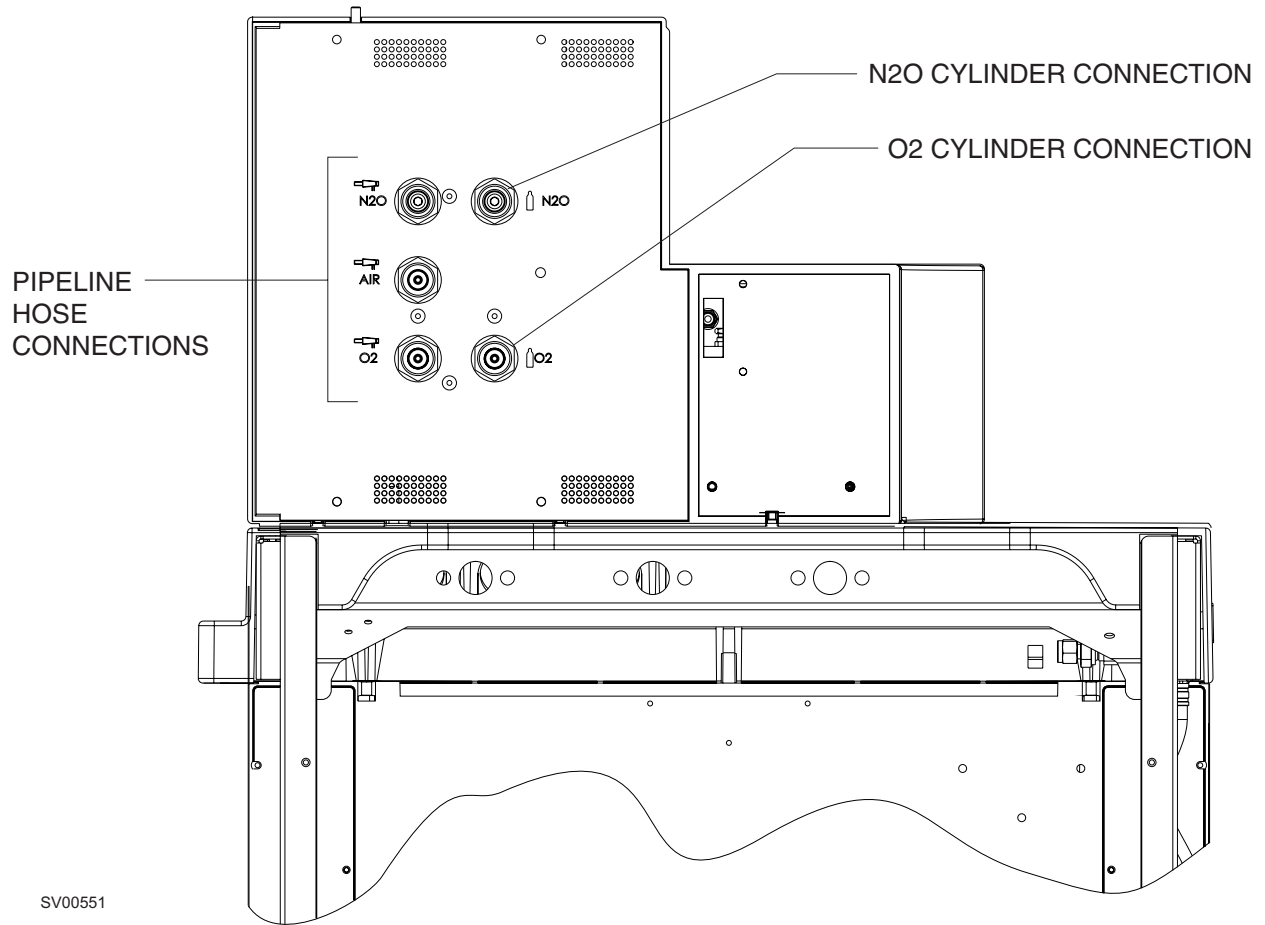

Figure 2-3. Back View Showing Gas Pipeline and Cylinder Yokes



SV00551

**Figure 2-4. Back View Showing Gas Pipeline and Cylinder Hose Connections
(machines without cylinder yokes)**

2.2 Fabius GS Function Diagram

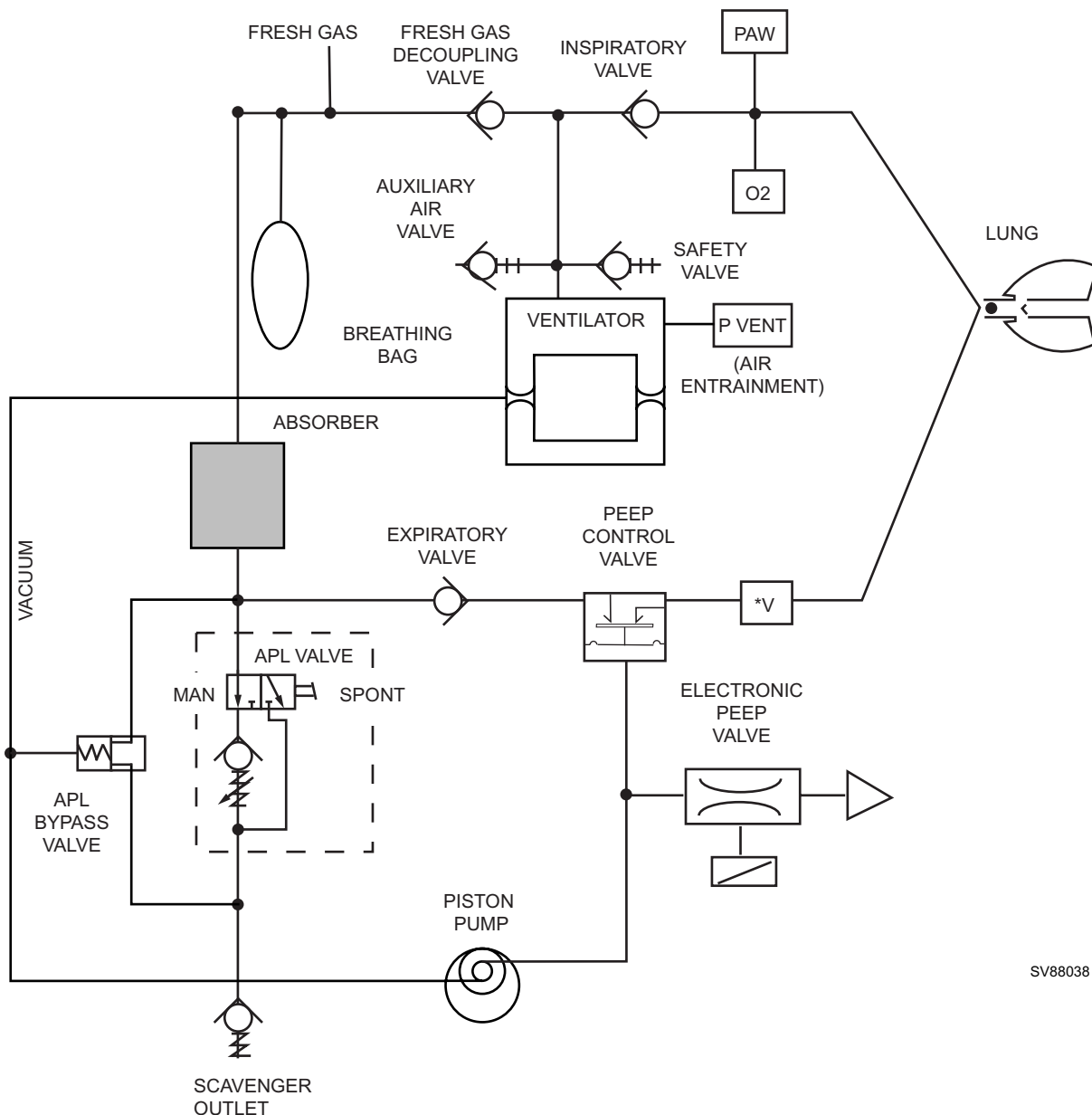

SV88038

Figure 2-5. Function diagram of Fabius GS - Typical for Breathing System P/N 4116398 or 4117529

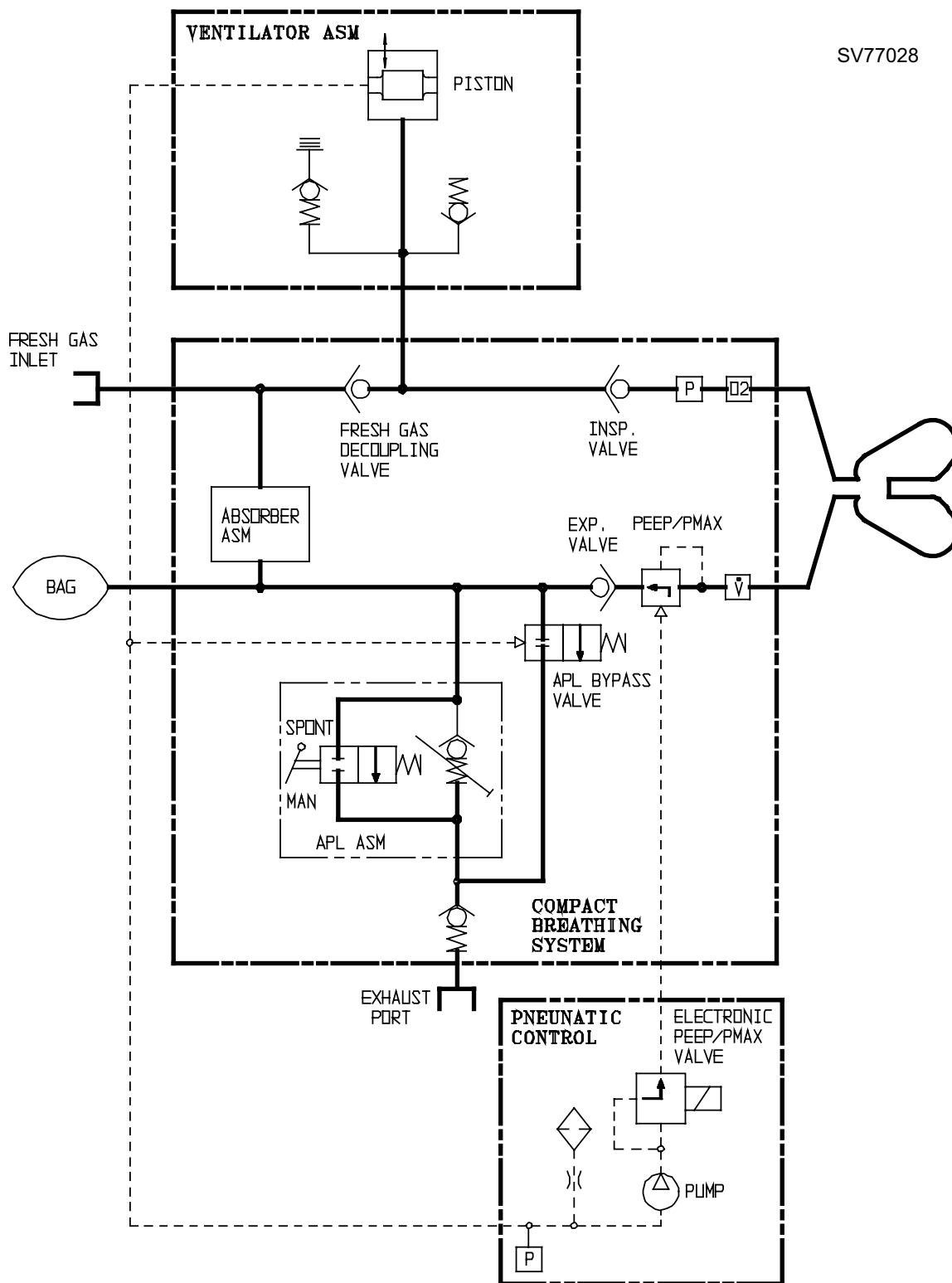

Figure 2-6. Function diagram of Fabius GS - Typical for Breathing System P/N 4118378 or 4118379

2.3 Battery Backup

Fabius GS backup power is provided by two series-connected 12 V rechargeable batteries. These batteries remain on charge as long as the machine is plugged into an active AC outlet. Should power to the main controller PCB assembly fail while the machine is in operation, the batteries will allow the machine to continue operating for a minimum of 45 minutes, provided the batteries are fully charged.

The batteries are located within the controller housing and are accessible by opening the ventilator compartment. The 3.15A battery fuse is located on the power entry panel at the back of the machine.

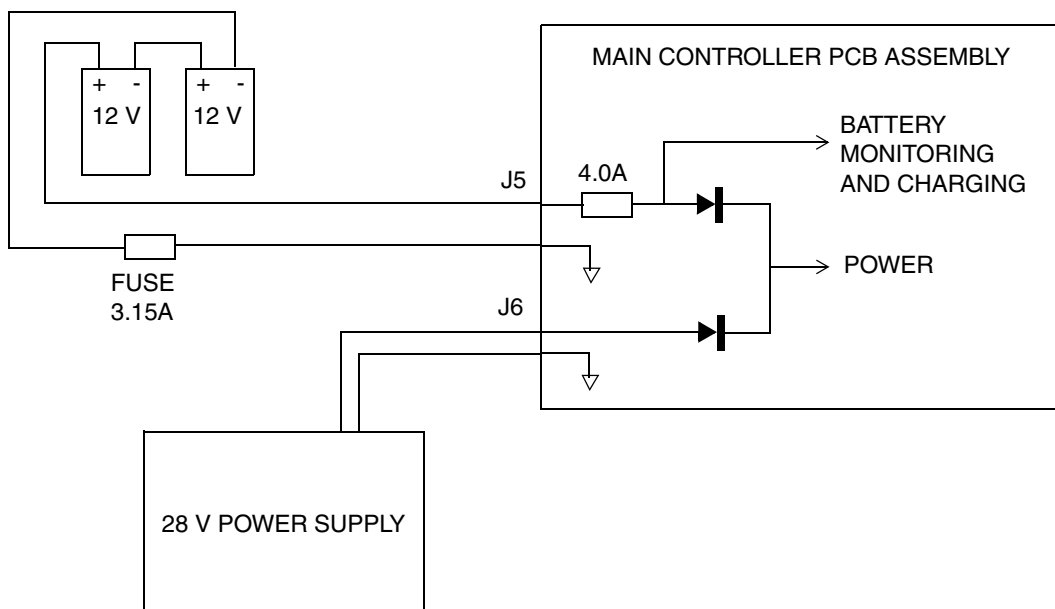

Figure 2-7. Battery Backup Arrangement

2.4 Fabius GS Piping Diagram

SV00454

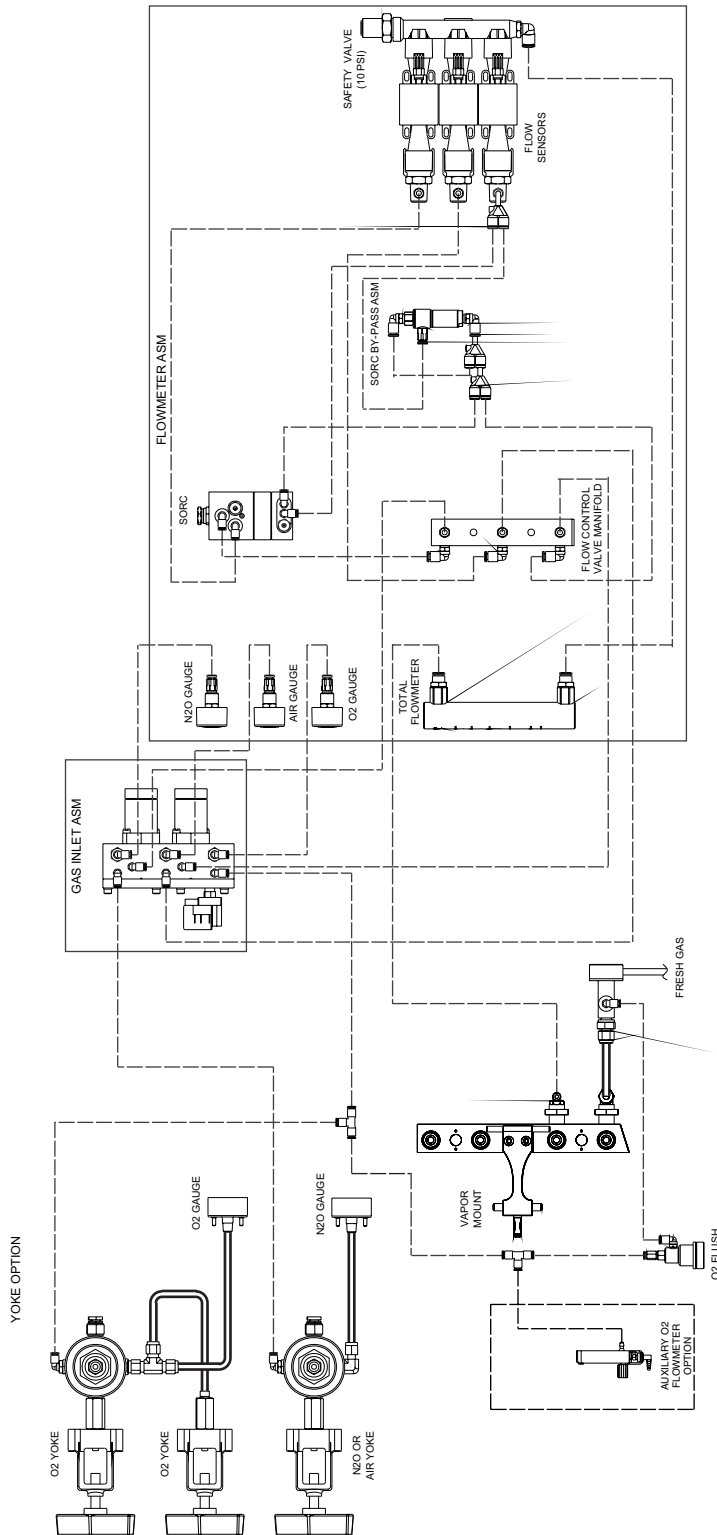

Figure 2-8. Fabius GS Piping Diagram

2.5 Function Description of Gas Box

The supply gases flow through the filters and non-return valves in the gas inlet assembly. Pipeline supply pressures are indicated on gauges located on the flowmeter assembly. Cylinder pressure gauges are located on the trolley assembly. The pressures of O₂ and N₂O delivered to the flowmeter assembly are set by regulators on the gas inlet assembly.

Should the O₂ supply fail or its pressure decrease below a certain limit, the O₂ supply pressure alarm switch signals an alarm.

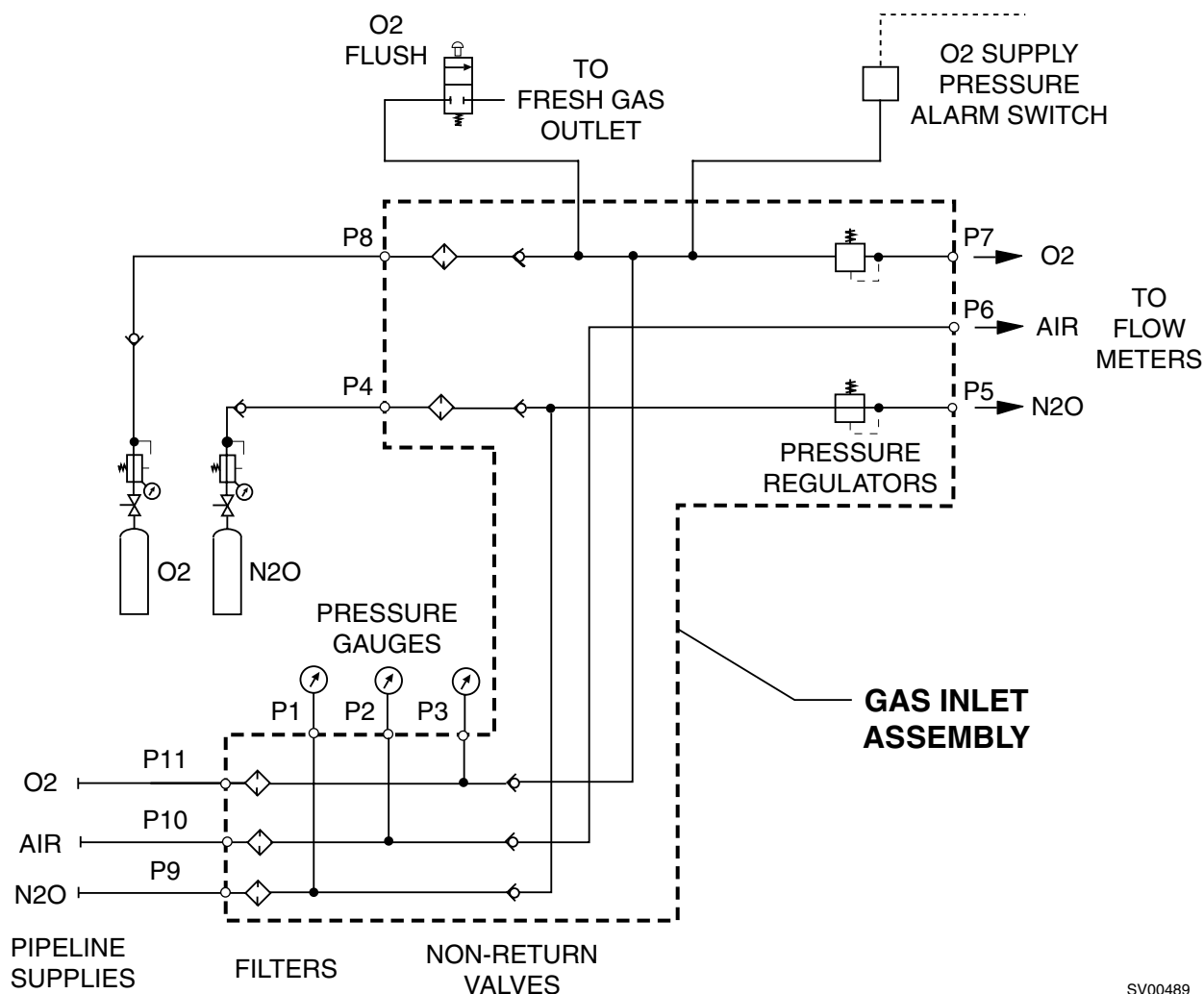
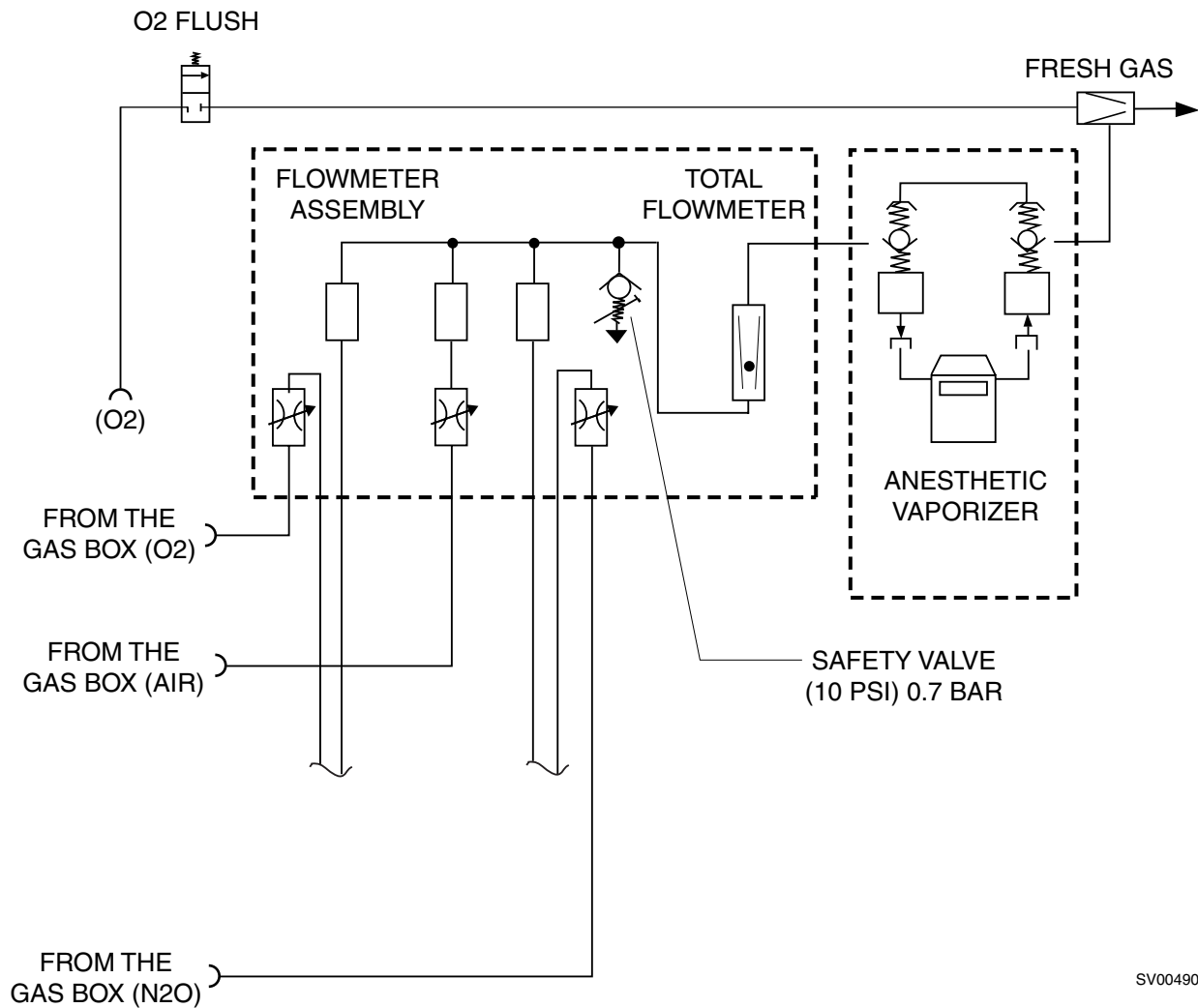

Figure 2-9. Gas Box Function Diagram, part 1

SV00489

If the O₂ flush button is pressed, oxygen is delivered to the fresh gas outlet. The fresh-gas ejector prevents the fresh gas from flowing back into the anesthetic vaporizer. This avoids an increase in the anesthetic gas concentration.



SV00490

Figure 2-10. Gas Box Function Diagram, part 2

2.6 SORC (Sensitive Oxygen Ratio Controller)

The SORC is a control element that functions like an N₂O shut-off device and ensures a vital O₂ concentration in the fresh gas. In the event of an O₂ shortage, the SORC limits the N₂O flow such that the O₂ concentration in the fresh gas does not decrease below 23 vol.%.

If the O₂ flow control valve is closed or if the O₂ flow is lower than or equal to 200 mL/min, the SORC interrupts the N₂O flow.

N₂O can be added when the O₂ flow is approx. 300 mL/min. In this case, the SORC also prevents O₂ concentrations below 23 vol.%.

The SORC bypass allows O₂ to bypass the restrictor in the SORC when O₂ flows above 10 L/min. are needed.

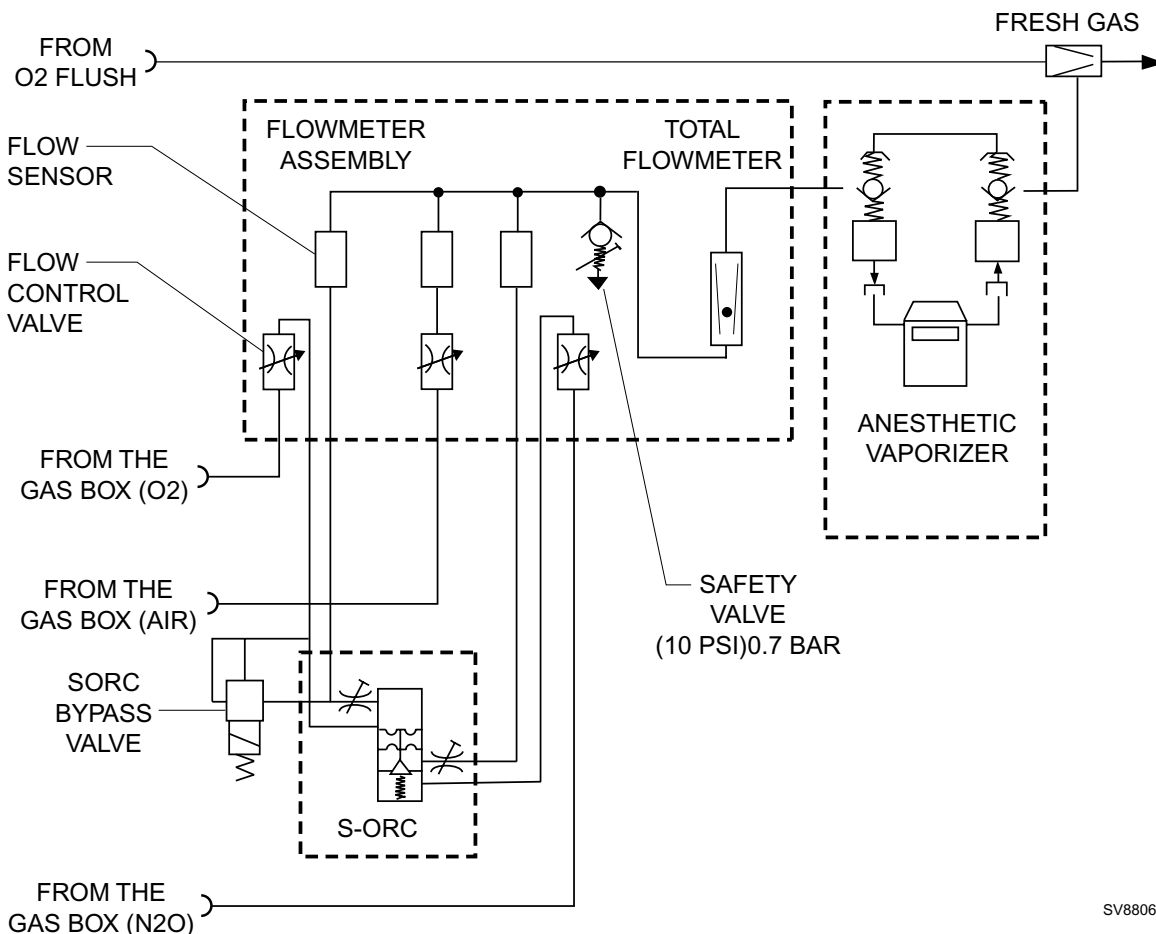

SV88062

Figure 2-11. SORC function diagram, part 1

The flow control valves are used to adjust the O₂ and N₂O flows.

Restrictors located at the outlets of the SORC generate back-pressures. These back-pressures exert a force on the control diaphragms of the SORC. The O₂ back-pressure opens the SORC. The N₂O back-pressure closes the SORC. The pressure ratio at the control diaphragm affects the N₂O flow.

The restrictors and the spring tension are dimensioned such that a minimum concentration of 23 vol.% O₂ is always ensured. The maximum O₂ flow is approx. 12 L/min.

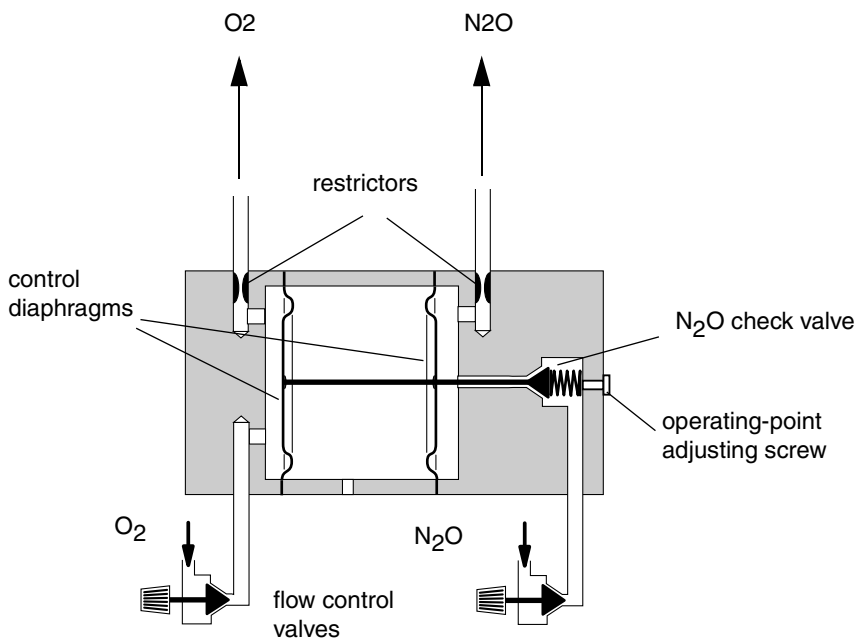

Figure 2-12. SORC function diagram, part 2

2.7 Compact Breathing System, Cosy II

The Cosy II compact breathing system allows various modes of patient ventilation: manual and spontaneous breathing, volume controlled, and pressure controlled. The lever style APL valve (adjustable pressure limiting valve) has a selector which can be used to toggle between "MAN" and "SPONT".

In the "MAN" position, the compact breathing system is closed to atmosphere. This position is used for manual ventilation of the patient. The APL valve opening pressure can be adjusted from 5 to 70 cmH₂O.

In the "SPONT" position the APL valve is open to atmosphere. This position is used for spontaneous breathing.

The pressure limit (P_{max}) can also be adjusted (through front panel interface) during volume control from 15 cmH₂O to 70 cmH₂O using the control box and the PEEP P_{max} valve.

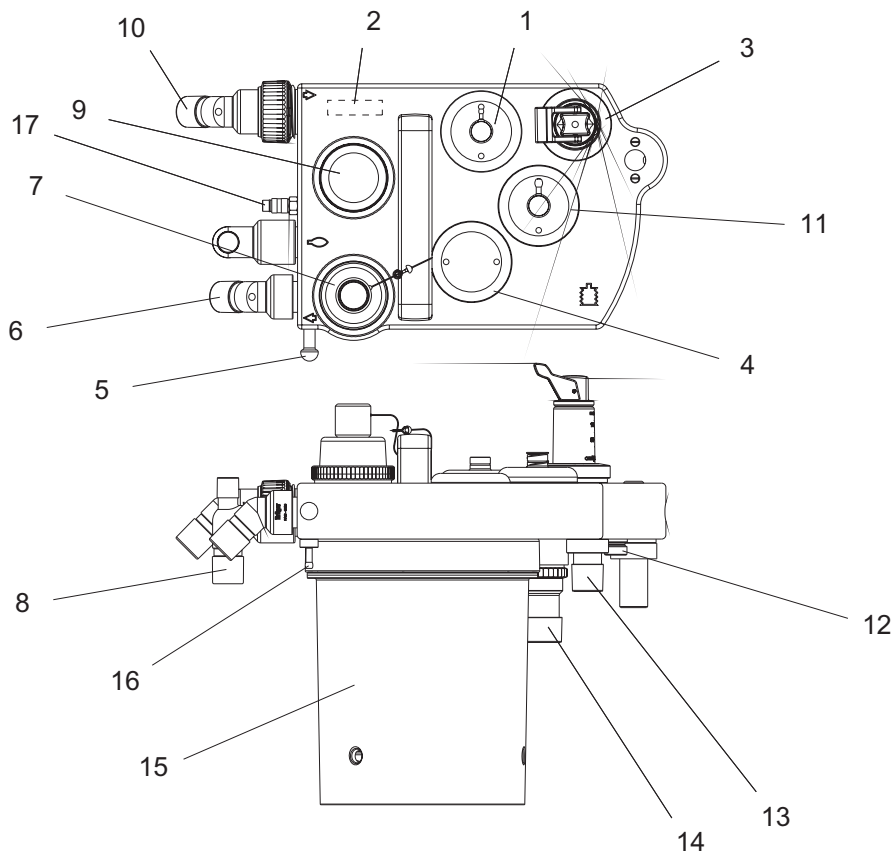

SV00493

Figure 2-13. Compact breathing system, Cosyll - Typical for P/N 4116398 or 4117529

Key

- | | | | |
|---|--|----|---|
| 1 | PEEP/Pmax valve | 10 | Expiratory port |
| 2 | Flow sensor (Spirolog) | 11 | APL Bypass valve |
| 3 | MAN/SPONT- APL Valve | 12 | Fresh-gas port |
| 4 | Fresh-gas decoupling valve | 13 | Ventilator port |
| 5 | Breathing bag hook | 14 | Anesthetic gas scavenging port |
| 6 | Inspiratory port | 15 | Absorber |
| 7 | Inspiratory valve and O ₂ sensor port | 16 | Pressure sensor connector |
| 8 | Breathing bag terminal and Y-piece plug | 17 | Exhaust port, anesthetic monitor return (non-U.S. systems only) |
| 9 | Expiratory valve | | |

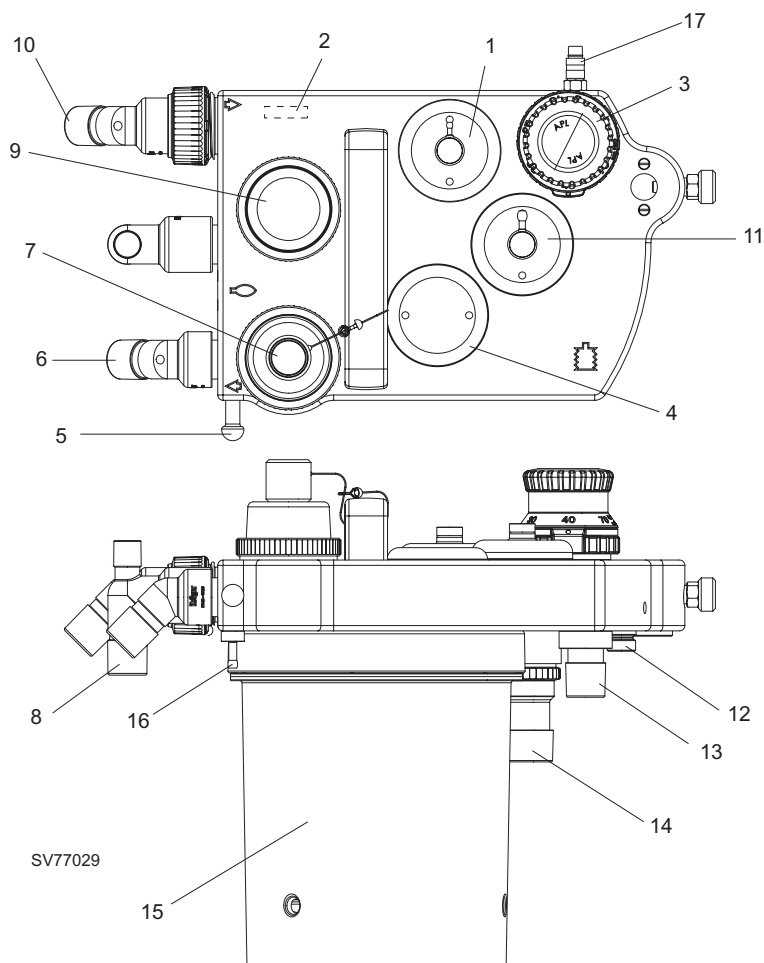

Figure 2-14. Compact breathing system, Cosyll - Typical for P/N 4118378 or 4118379

Key

- | | | | |
|---|---|----|---|
| 1 | PEEP/Pmax valve | 10 | Expiratory port |
| 2 | Flow sensor (Spirolog) | 11 | APL Bypass valve |
| 3 | MAN/SPONT- APL Valve | 12 | Fresh-gas port |
| 4 | Fresh-gas decoupling valve | 13 | Ventilator port |
| 5 | Breathing bag hook | 14 | Anesthetic gas scavenging port |
| 6 | Inspiratory port | 15 | Absorber |
| 7 | Inspiratory valve and O2 sensor port | 16 | Pressure sensor connector |
| 8 | Breathing bag terminal and Y-piece plug | 17 | Exhaust port, anesthetic monitor return (non-U.S. systems only) |
| 9 | Expiratory valve | | |

2.7.1 Function Description: Manual Ventilation

Manual Ventilation: General

During manual ventilation, the APL valve is set to the "MAN" position. The patient system safety valve is activated. The piston of the ventilator is in the upper end position in order to reduce the volume of the ventilator.

Manual Ventilation: Inspiration

During inspiration, expiratory valve remains closed. When the clinician compresses the breathing bag the gas mixture (expiratory gas and fresh gas) flows through the fresh-gas decoupling valve, the inspiratory valve, the O₂ sensor, the inspiratory hose, and the Y-piece into the patient's lung. The pressure sensor measures the airway pressure. The APL valve limits the ventilation pressure. Any excess amount of the gas mixture flows through the APL valve and the non-return valve to the anesthetic gas scavenging system.

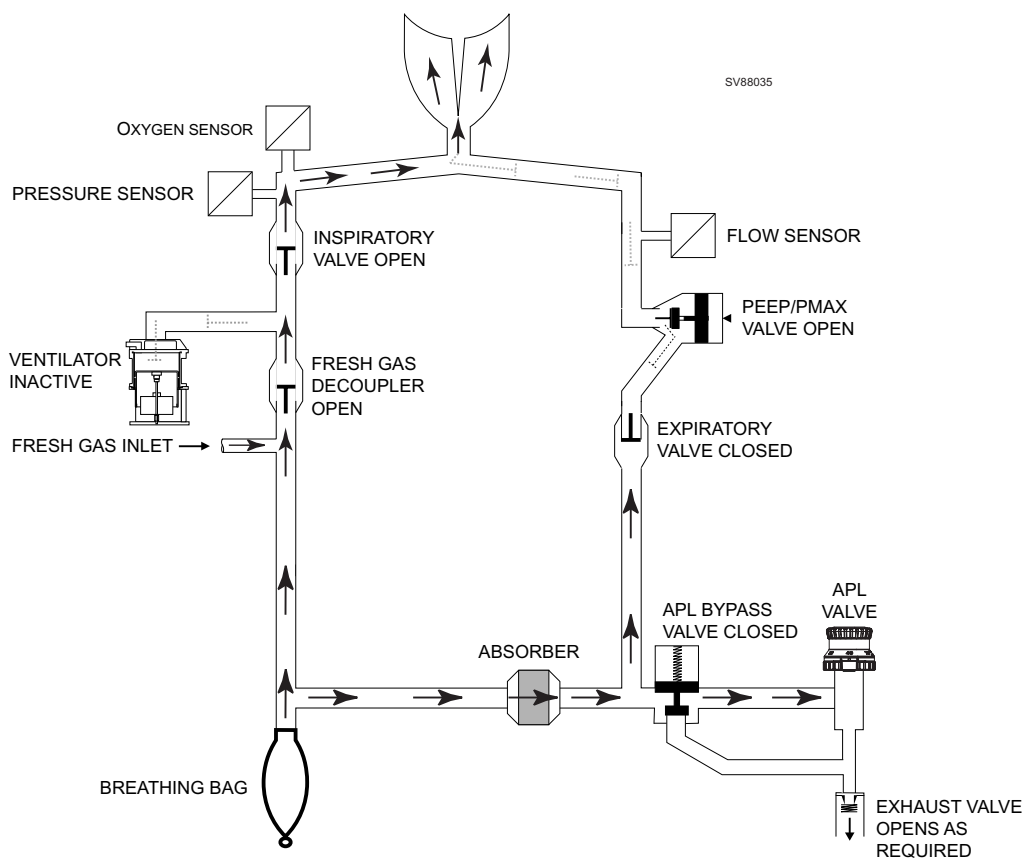

Figure 2-15. Manual ventilation (inspiration) - Typical for Breathing System P/N 4116398 or 4117529

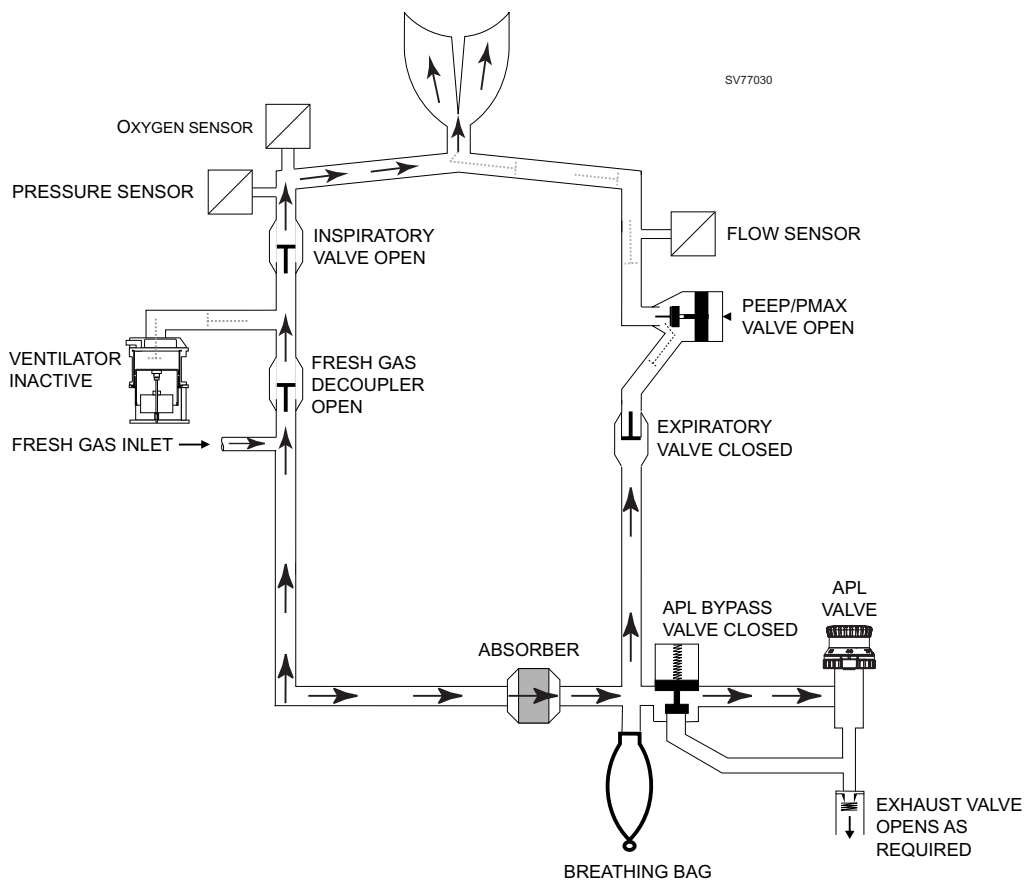

Figure 2-16. Manual ventilation (inspiration) - Typical for Breathing System P/N 4118378 or 4118379

Manual Ventilation: Expiration - Typical for Breathing System P/N 4116398 or 4117529

During expiration, the inspiratory valve remains closed and thus prevents the expiratory gas from flowing back into the inspiratory branch.

After releasing the breathing bag, the expiratory gas from the lung flows through the expiratory hose, the flow sensor, the PEEP Pmax valve, the expiratory valve, and through the absorber into the breathing bag. At the same time, new fresh gas flows into the breathing bag.

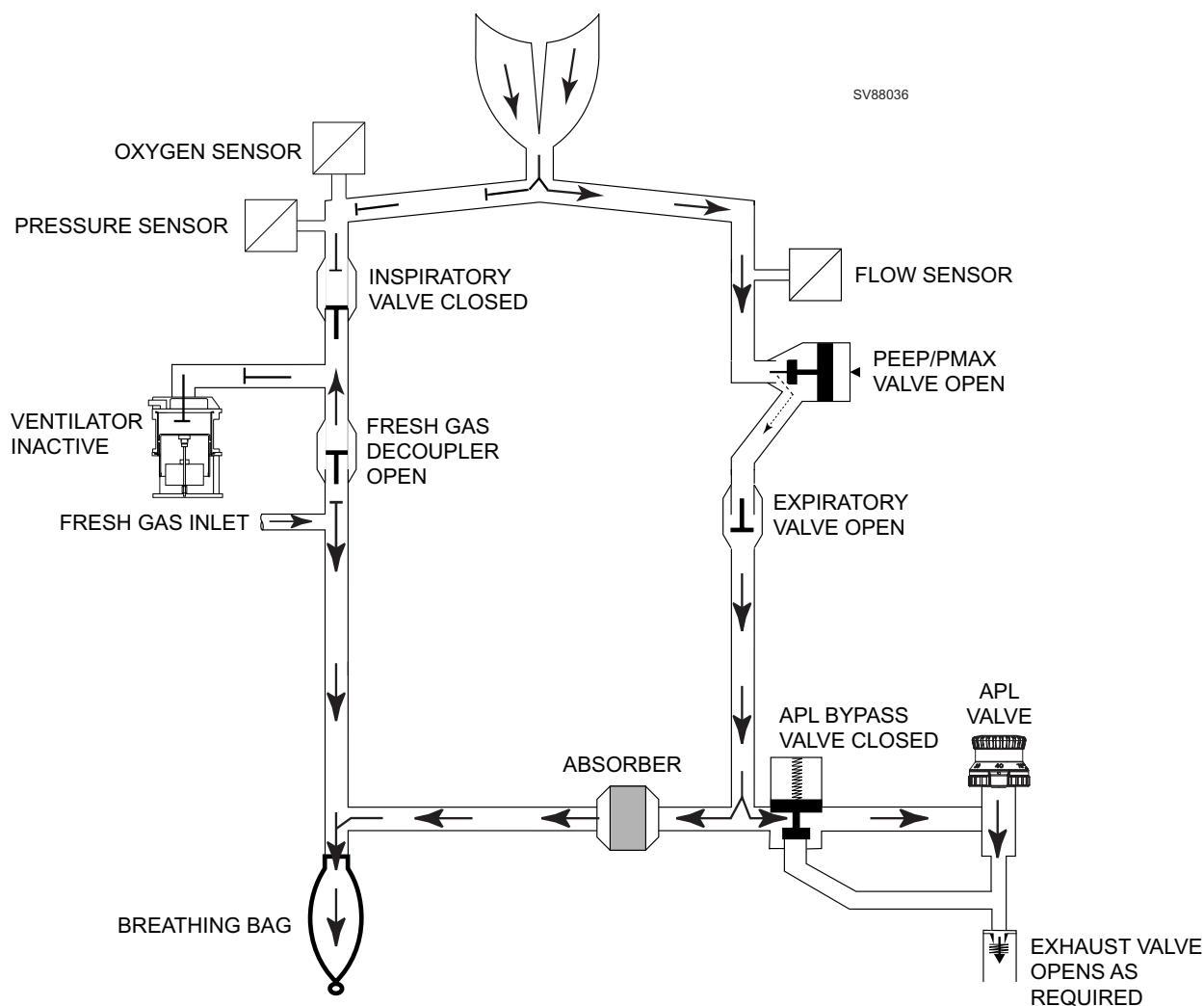

Figure 2-17. Manual ventilation (expiration) - Typical for Breathing System P/N 4116398 or 4117529

Manual Ventilation: Expiration - Typical for Breathing System P/N 4118378 or 4118379

During expiration, the inspiratory valve remains closed and thus prevents the expiratory gas from flowing back into the inspiratory branch.

After releasing the breathing bag, the expiratory gas from the lung flows through the expiratory hose, the flow sensor, the PEEP Pmax valve, the expiratory valve, onto the breathing bag and through the absorber. At the same time, new fresh gas flows into the breathing bag.

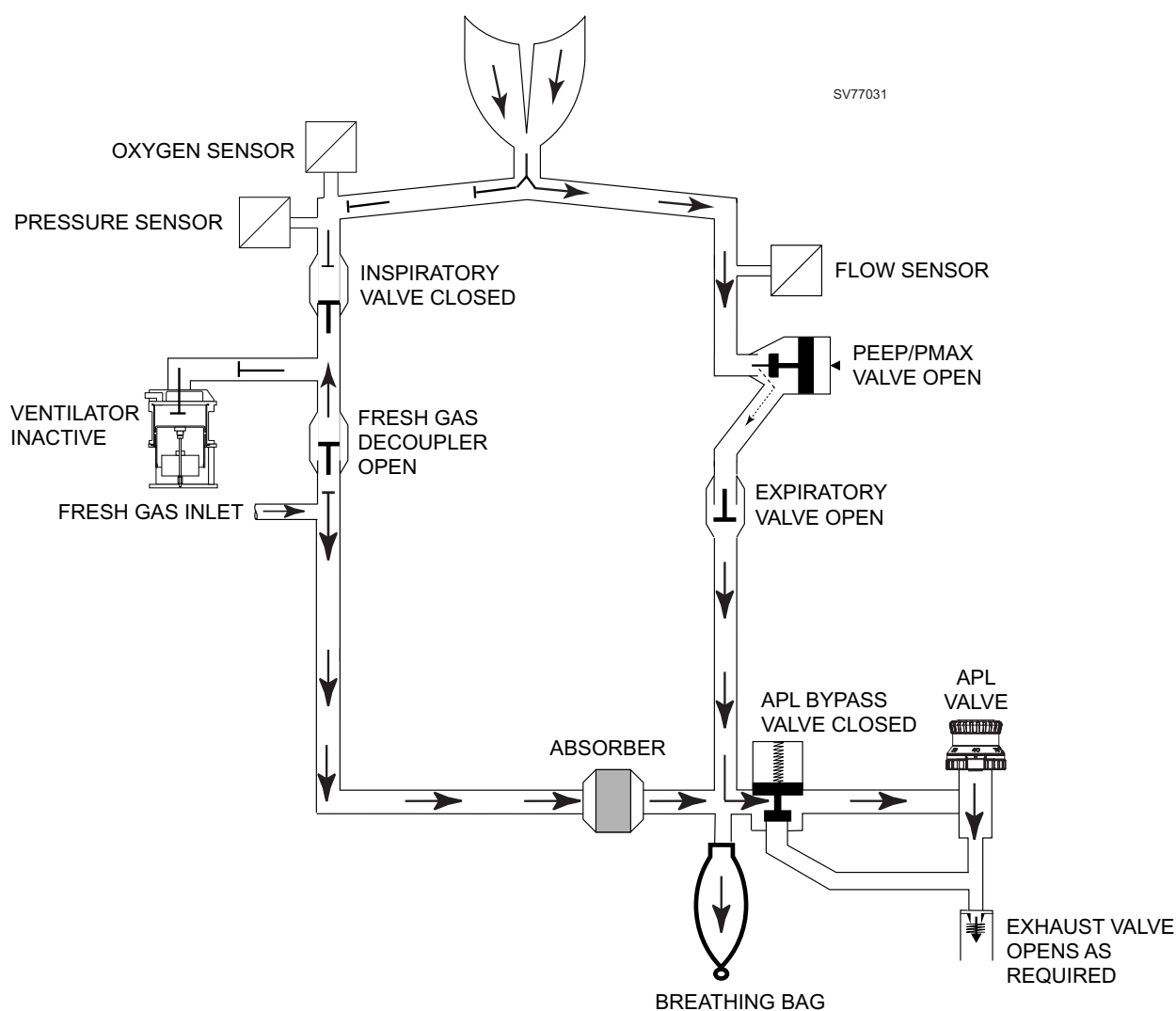

Figure 2-18. Manual ventilation (expiration) - Typical for Breathing System P/N 4118378 or 4118379

2.7.2 Function Description: Spontaneous Breathing

Spontaneous Breathing: General

A prerequisite for spontaneous breathing is that the patient is supplied with a sufficient amount of fresh gas. The APL valve selector must be set to the "SPONT" position. No pressure builds up in the compact breathing system.

Spontaneous Breathing: Inspiration

During inspiration, the expiratory valve remains closed thus preventing rebreathing of expiratory gas containing CO₂.

The patient inhales the gas mixture (expiratory gas and fresh gas) from the breathing bag. The gas mixture flows through the fresh-gas decoupling valve, the inspiratory valve, the O₂ sensor, the inspiratory hose, and through the Y-piece into the lung. The pressure sensor measures the airway pressure.

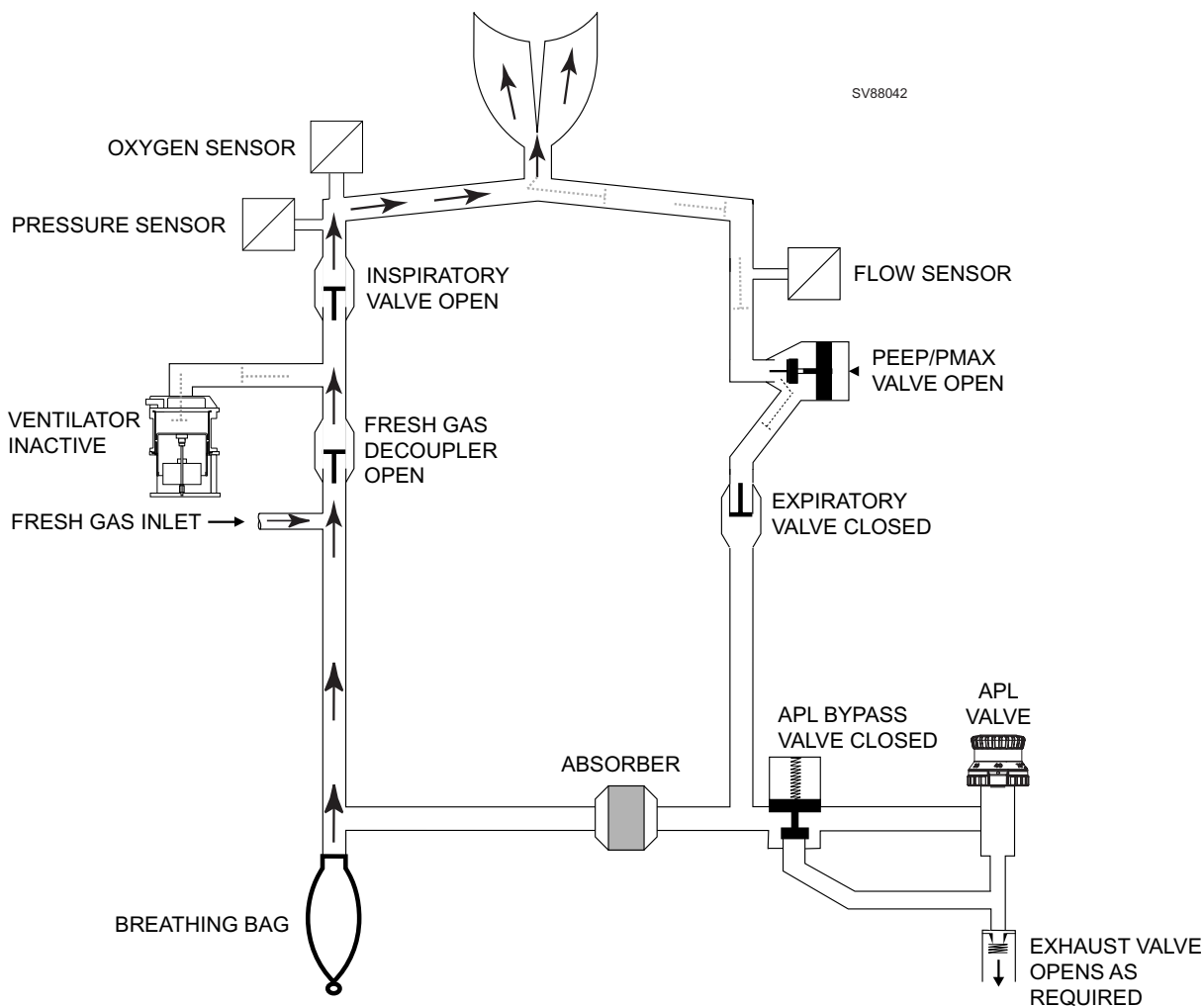

Figure 2-19. Spontaneous breathing (inspiration) - Typical for Breathing System P/N 4116398 or 4117529

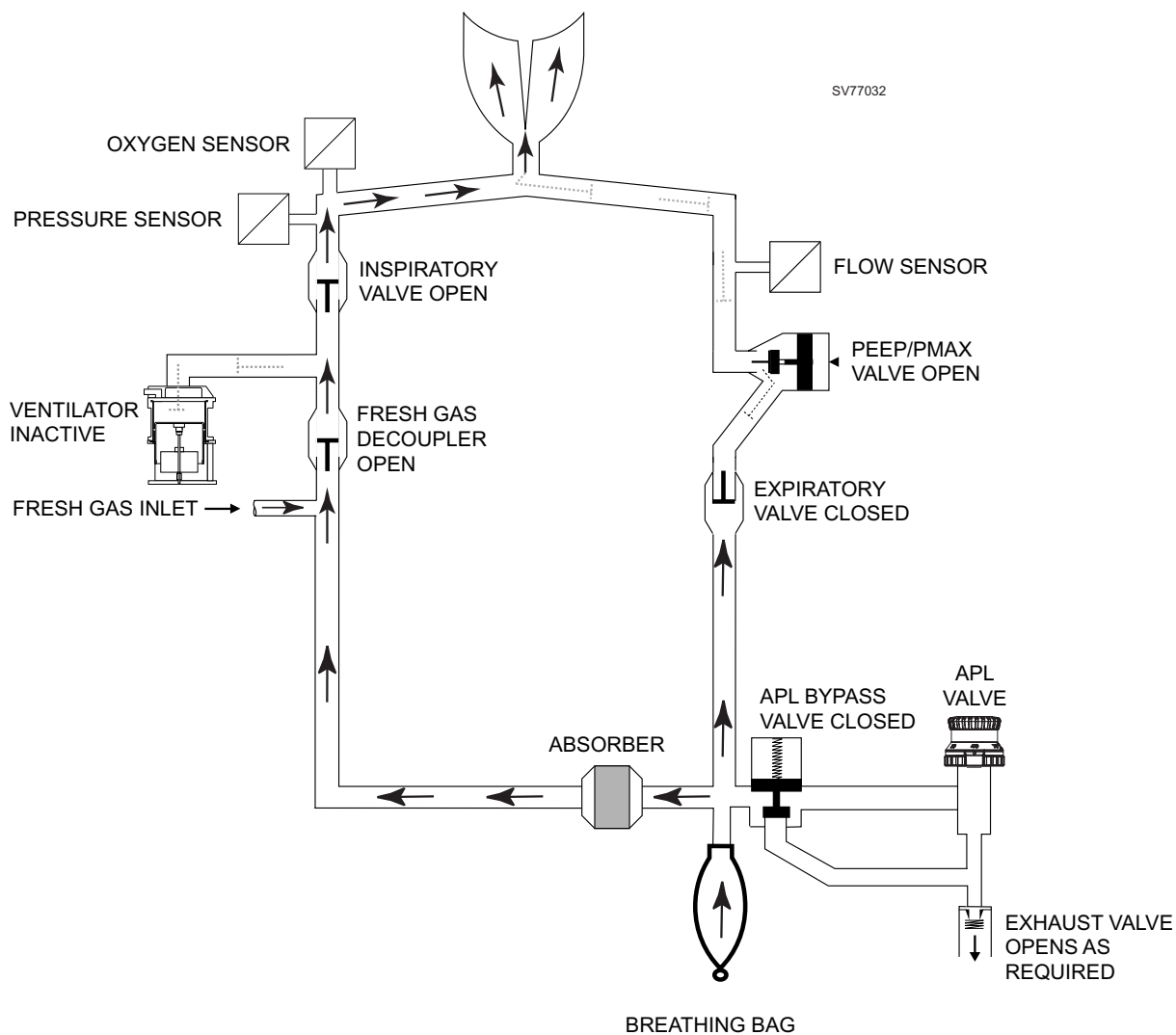

Figure 2-20. Spontaneous breathing (inspiration) - Typical for Breathing System P/N 4118378 or 4118379

Spontaneous Breathing: Expiration - Typical for Breathing System P/N 4116398 or 4117529

During expiration, the inspiratory valve remains closed thus preventing the expiratory gas from flowing back into the inspiratory branch.

The APL valve is open, regardless of its pressure setting.

The expiratory gas flows from the lung through the expiratory hose, the flow sensor, the PEEP control valve, the expiratory valve, and through the absorber into the breathing bag. At the same time, new fresh gas flows into the breathing bag.

When the breathing bag is full, any excess gas mixture flows through the non-return valve into the anesthetic gas scavenging system.

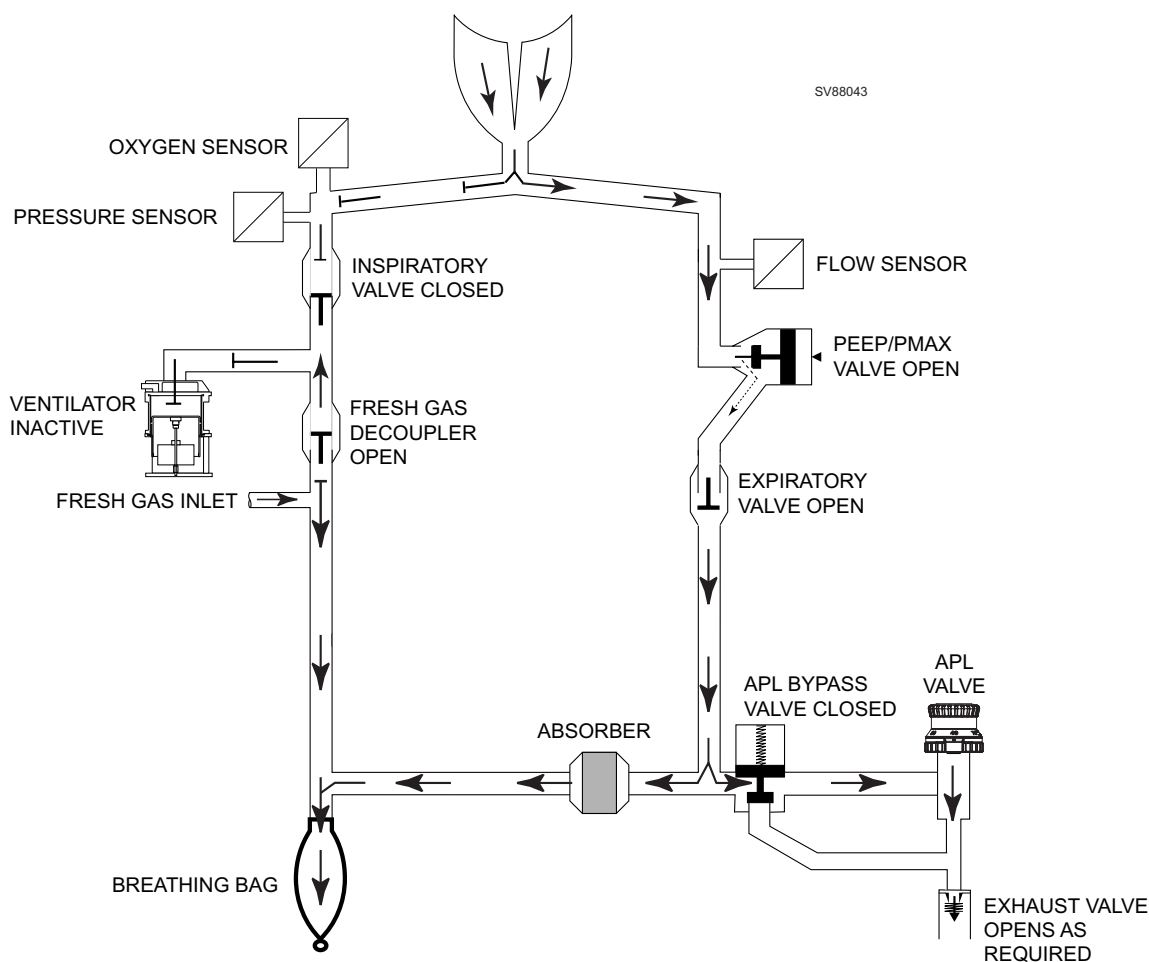

Figure 2-21. Spontaneous breathing (expiration) - Typical for Breathing System P/N 4116398 or 4117529

The CO₂ is scrubbed from the expiratory gas by the soda lime contained in the absorber. The fresh gas replaces the anesthetic and oxygen taken up by the patient.

Spontaneous Breathing: Expiration - Typical for Breathing System P/N 4118378 or 4118379

During expiration, the inspiratory valve remains closed thus preventing the expiratory gas from flowing back into the inspiratory branch.

The APL valve is open, regardless of its pressure setting.

The expiratory gas flows from the lung through the expiratory hose, the flow sensor, the PEEP control valve, the expiratory valve, the breathing bag, and through the absorber. At the same time, new fresh gas flows into the breathing bag.

When the breathing bag is full, any excess gas mixture flows through the non-return valve into the anesthetic gas scavenging system.

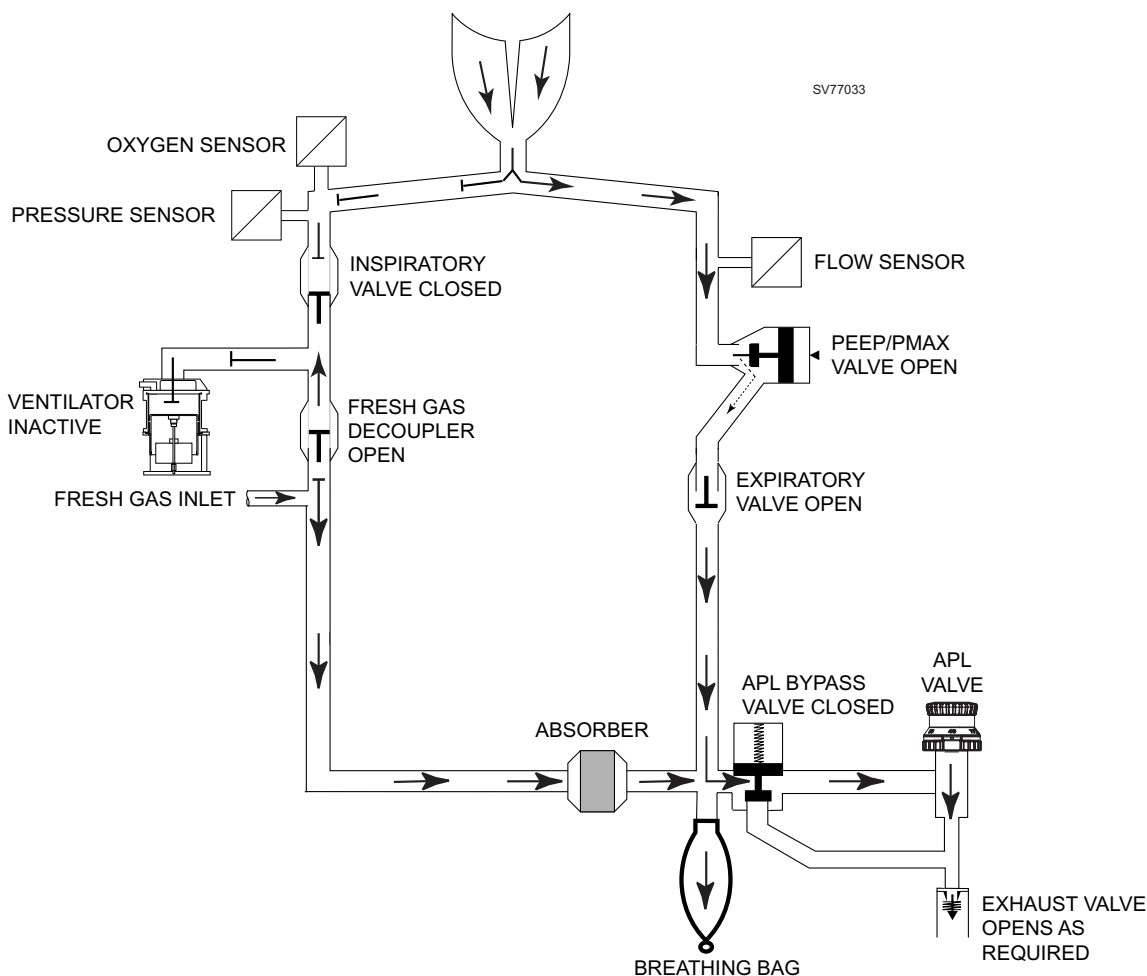

Figure 2-22. Spontaneous breathing (expiration) - Typical for Breathing System P/N 4118378 or 4118379

2.7.3 Function Description: Volume/Pressure Mode Ventilation

Volume Control Mode: General

A prerequisite for volume control is that the patient is supplied with a sufficient amount of fresh gas.

The APL bypass valve opens in volume mode, allowing excess gas to be vented to the scavenging system regardless of the MAN-SPONT valve setting.

The safety valve of the patient system makes sure that no pressures greater than 75 cmH₂O build up in the system.

During ventilation, the pressure limit (P_{max}) can be adjusted at the user interface.

Volume/Pressure Control Mode: Inspiration

During inspiration, the PEEP/Pmax valve remains closed. The control pressure present at the PEEP/Pmax valve varies with the set pressure limit (Pmax).

The pressure generated by the ventilator's piston closes the fresh-gas decoupling valve. The gas mixture (expiratory gas and fresh gas) flows through the inspiratory valve, the O₂ sensor, the inspiratory hose, and through the Y-piece into the lung. The pressure sensor measures the airway pressure. The ventilation pressure cannot exceed the pressure limit (Pmax) set on the control box because the PEEP/Pmax valve opens. The fresh gas then fills the breathing bag.

Any excess fresh gas flows through the open APL bypass valve, and through the non-return valve into the anesthetic gas scavenging system.

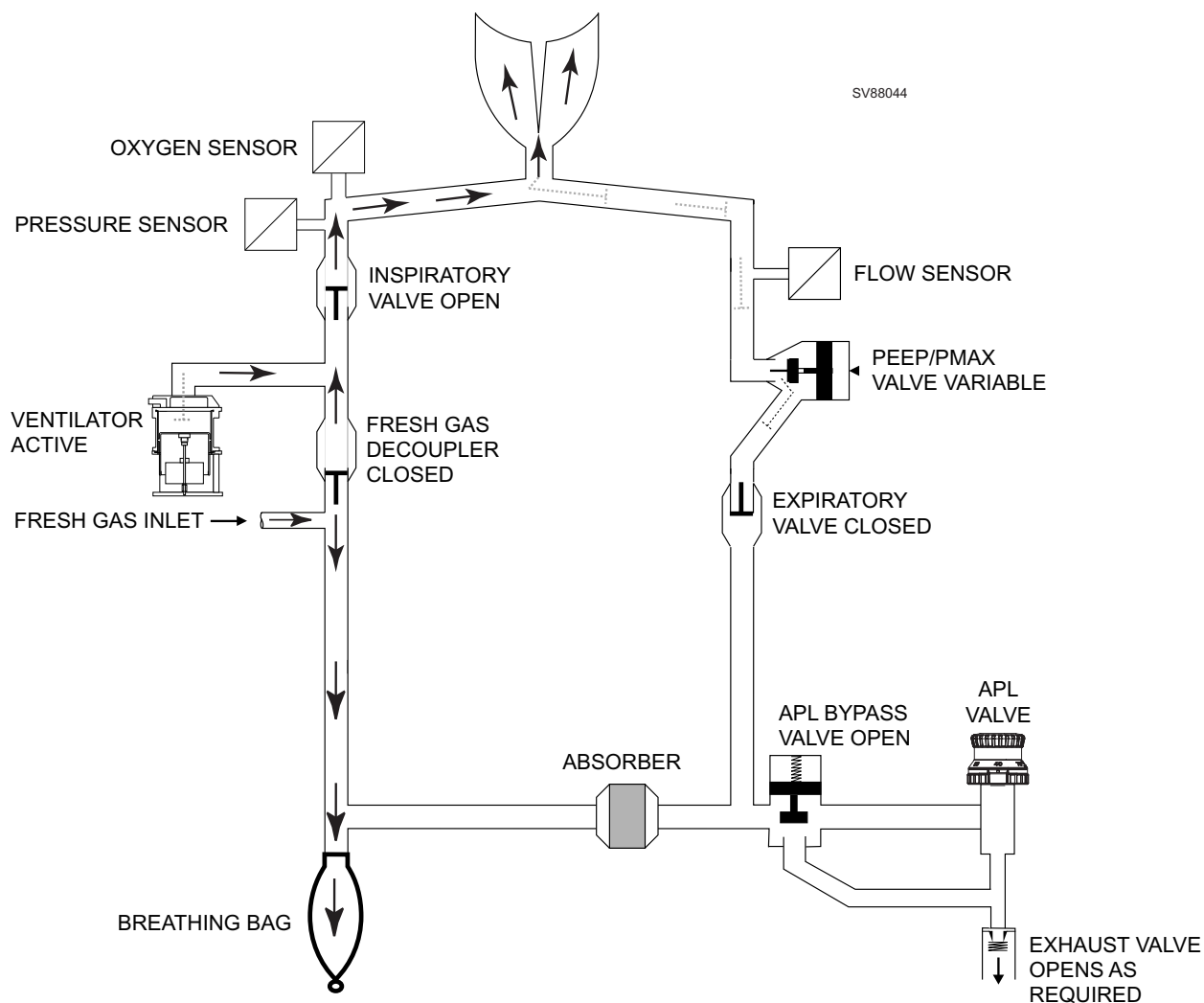

Figure 2-23. Volume control ventilation (inspiration) - Typical for Breathing System P/N 4116398 or 4117529

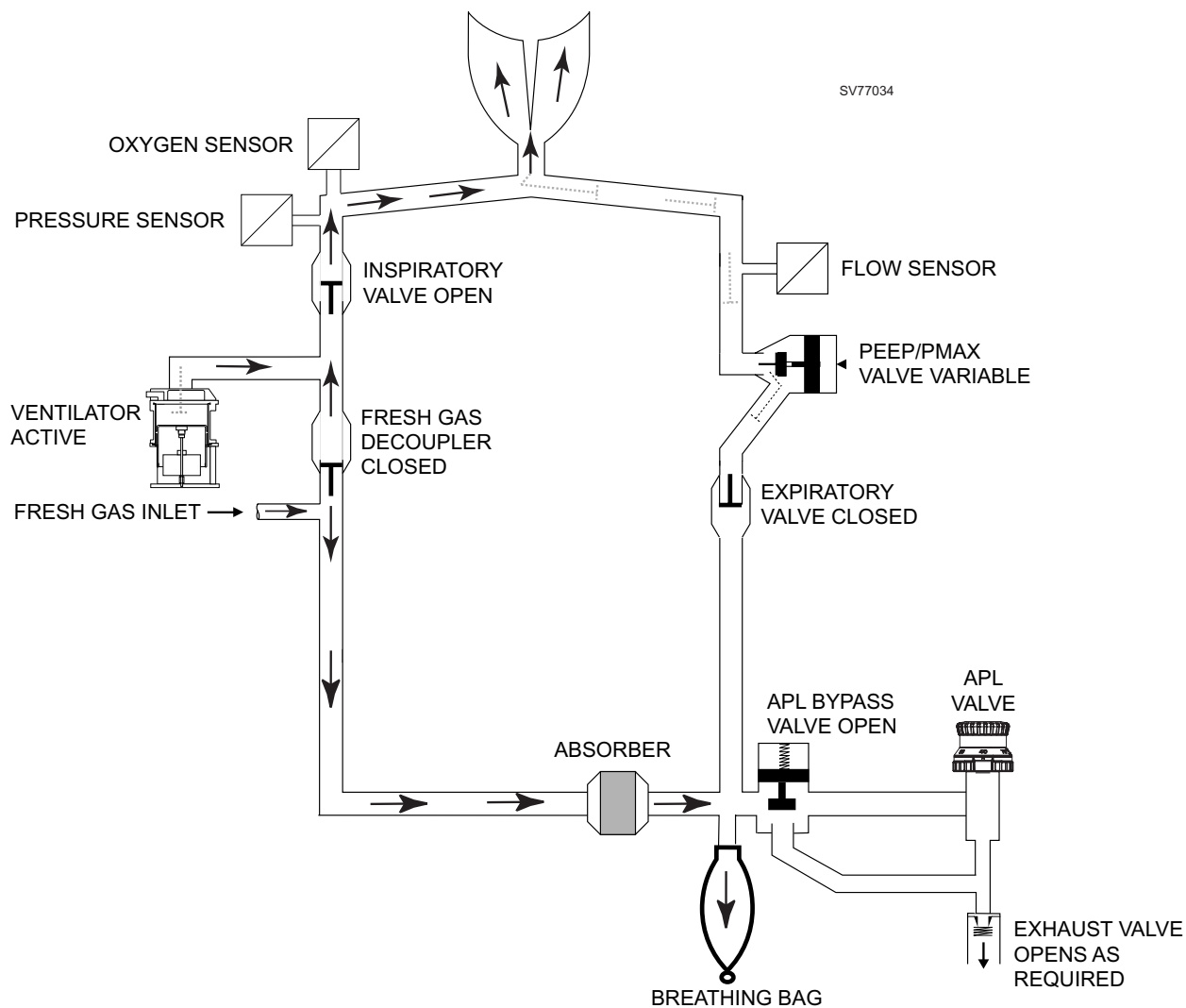

Figure 2-24. Volume control ventilation (inspiration) - Typical for Breathing System P/N 4118378 or 4118379

Volume/Pressure Control Mode: Expiration

During expiration, the inspiratory valve remains closed thus preventing rebreathing into the inspiratory branch.

The expiratory gas from the lung flows through the expiratory hose, the flow sensor, the PEEP/PEEP valve, the expiratory valve, and through the absorber back into the breathing bag mixing with fresh gas also flowing into the breathing bag.

The ventilator's piston moves back drawing the gas mixture needed for the next inspiration into the piston space.

Any excess fresh-gas flows through the APL bypass valve, and through the non-return valve into the anesthetic gas scavenging system.

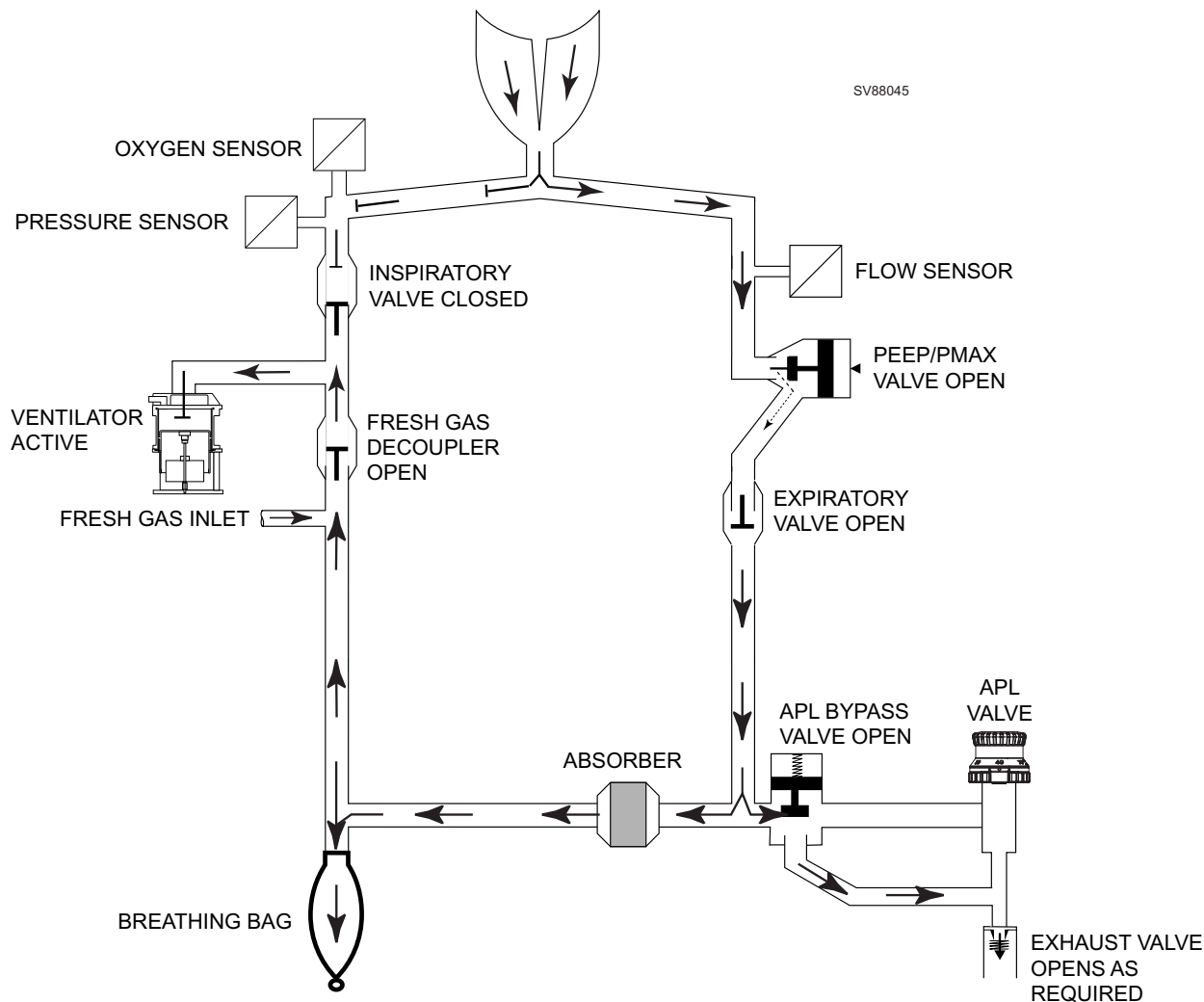

Figure 2-25. Volume control ventilation (expiration) - Typical for Breathing System P/N 4116398 or 4117529

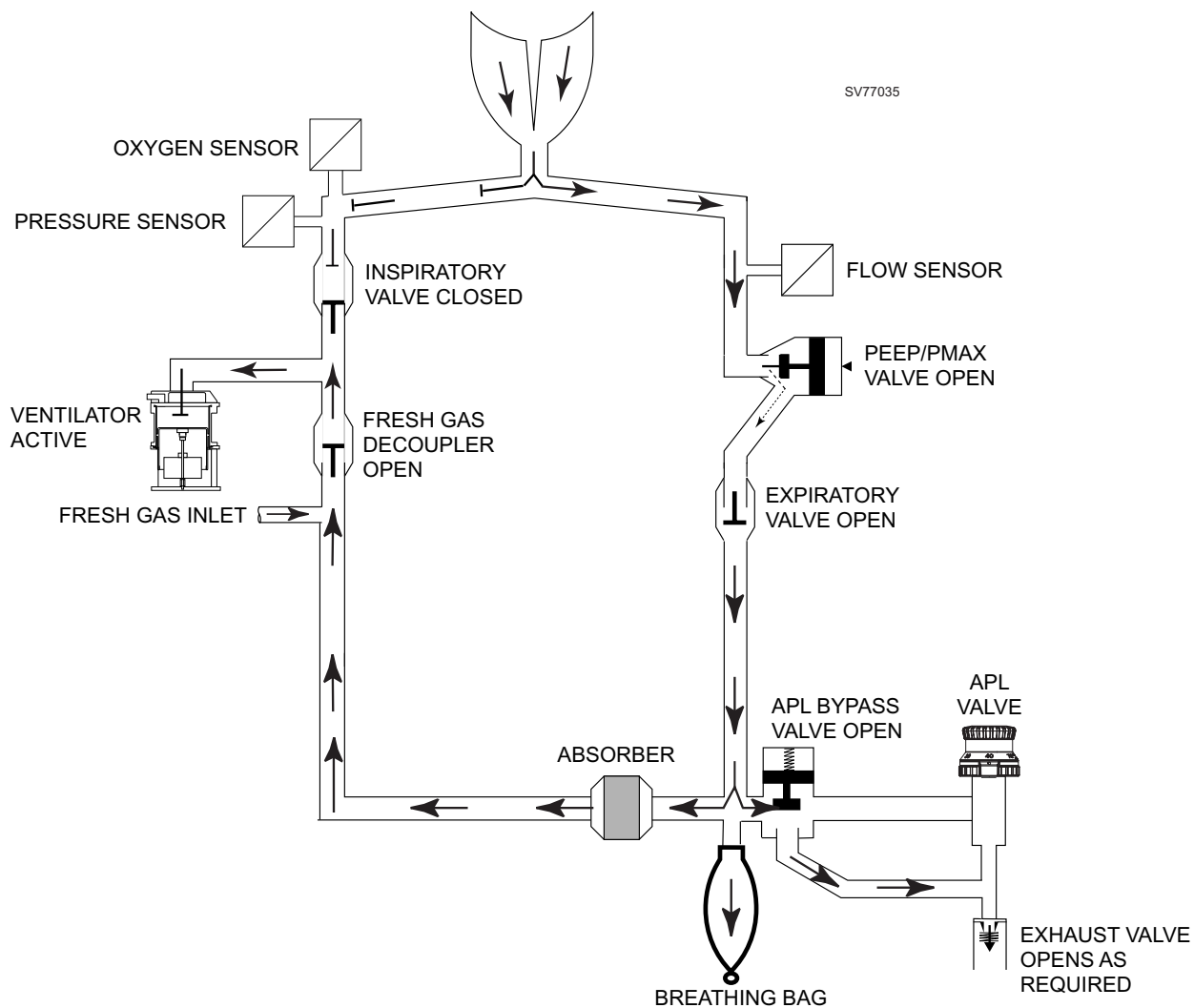

Figure 2-26. Volume control ventilation (expiration) - Typical for Breathing System P/N 4118378 or 4118379

2.7.4 Cosy II Absorber

The absorber canister is filled with fresh soda lime. The soda lime scrubs CO₂ from the respiratory expired gas.

Expired soda lime changes its color. The soda lime must be replaced when two thirds of the soda lime in the absorber canister is discolored.

2.8 Ventilator

The ventilator is located in a swing-out compartment at the left side of the Fabius GS. A hose terminal is provided on the left side of the compartment for connection to the breathing system. Fresh gas is delivered to the patient by a piston that is driven by a motor and ball-screw arrangement. A sight window on the compartment allows the operator to verify movement of the piston.

Two diaphragms (upper and lower) comprise a bag-type rolling seal that surrounds the piston. Vacuum from the pneumatic assembly (described in a later paragraph) is provided between the outside of the seal and the cylinder, to ensure proper operation of the seal during piston movement.

During inspiration the ventilator delivers fresh gas at a given volume, pressure and frequency. These parameters are set at the control panel. Refer to the Operator's Manual for details on ventilator settings, displays and controls. During expiration, the bag-type rolling seal fills with expired gas from the patient and with fresh gas stored in the breathing bag.

Power for the ventilator motor is distributed from the control PCB. A position sensor on the ventilator signals the control PCB when the piston reaches its lower limit. An incremental encoder on the motor shaft determines the number of revolutions and provides piston travel information to the control PCB.

Ventilator pressure is monitored by a transducer on the control PCB. Should the negative pressure relief valve on the patient assembly open, a Fresh Gas Low alarm is displayed, if enabled via Service Mode.

The ventilator pressure transducer is the same type as the one used for measuring airway pressure. A hose connects the transducer's positive pressure port to a hose barb located on the top cover of the ventilator. The purpose of this transducer is to allow the software to sense when a condition exists that would cause the ventilator negative pressure relief valve to open. The threshold used by the software for this condition is indicated in the table below. In normal use the primary cause for this condition is an insufficient amount of reserve gas in the breathing bag. The operator is alerted when this condition exists, with a medium priority "FRESH GAS LOW" alarm. This alarm may be disabled via Service Mode.

Software Version	Threshold
US units with SW>1.20	-8 mbar
US units with SW 1.20	-3 mbar
non-US units with SW≤ 1.20	-3 mbar
non-US units with SW>1.20	-8 mbar

The ventilator assembly is illustrated on the next page.

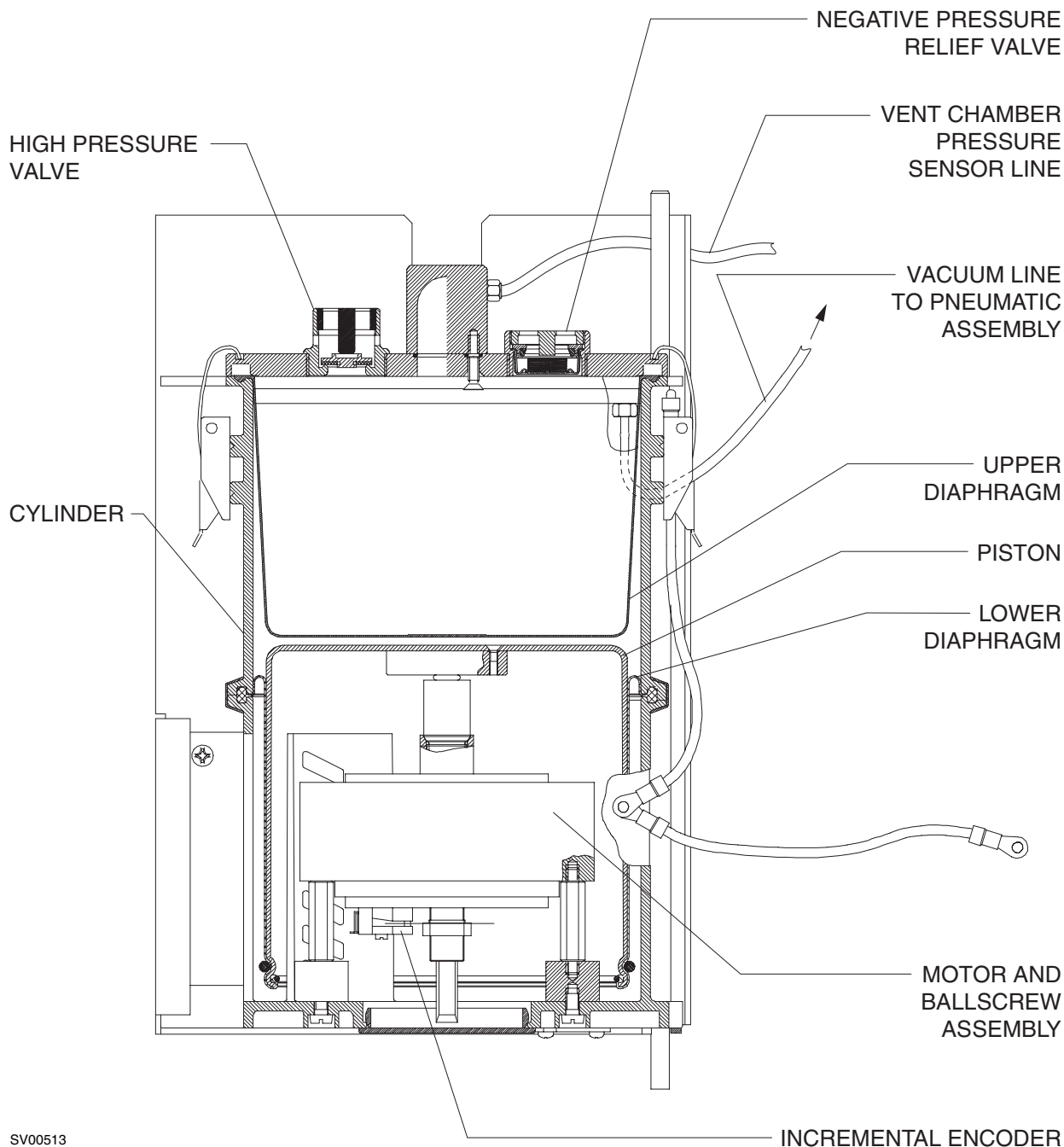

SV00513

Figure 2-27. Ventilator (piston shown in 'down' position)

The top of the ventilator assembly (patient system) contains two valves:

2.8.1 High Pressure Safety Valve

If the pressure limit control fails, the patient system high pressure safety valve limits the gas pressure. This valve is set to open at approximately 75 cmH₂O.

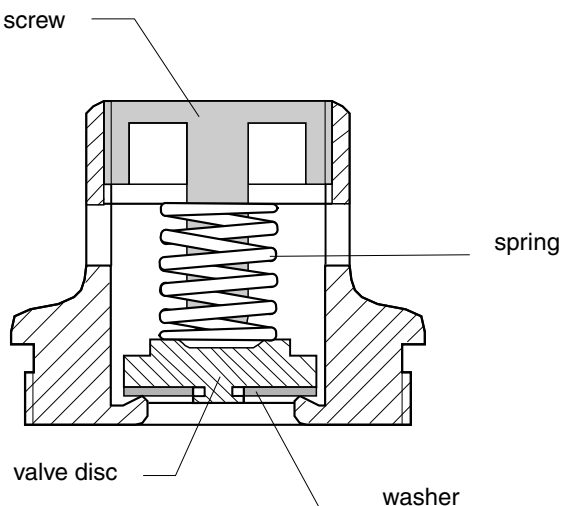

Figure 2-28. Sectional View of the Safety Valve

2.8.2 Negative Pressure Relief Valve

The negative pressure relief valve allows the patient to spontaneously breathe ambient air should the medical gas supply and/or Fabius GS fail. The opening pressure of this valve is indicated in the table below.

Software Version	Threshold
US units with SW>1.20	-8 mbar
US units with SW 1.20	-3 mbar
non-US units with SW ≤ 1.20	-3 mbar
non-US units with SW>1.20	-8 mbar

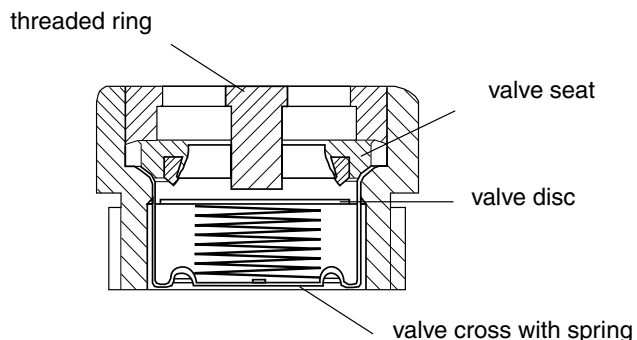

Figure 2-29. Sectional View of the Negative Pressure Relief Valve

2.9 Pneumatic System

The pneumatic assembly provides pressure for the PEEP valve control, and also provides vacuum for the ventilator bag-type rolling seals and the APL bypass valve control.

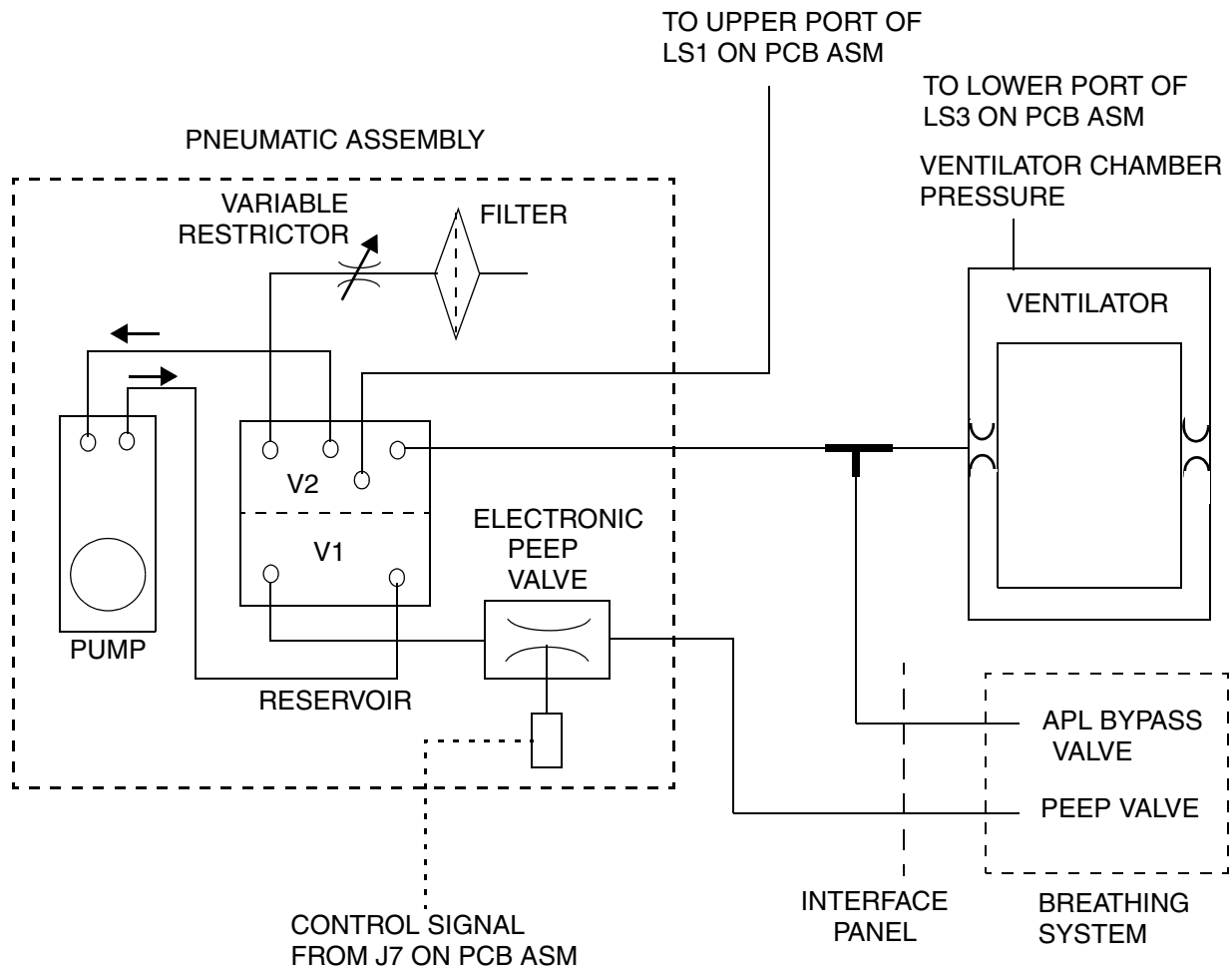

Figure 2-30. Pneumatic Control System Schematic

2.9.1 PEEP/Pmax Valve Control

When the Fabius GS is operating in the automatic mode, the pump on the pneumatic assembly is running, and the electronic PEEP valve receives a signal from the main control PCB. The amount of current supplied to the coil of the electronic PEEP valve is proportional to the PEEP value set by the operator, and controls the position of the diaphragm within the electronic PEEP valve. This then determines the control pressure applied to the proportional PEEP valve in the breathing system, which maintains the desired amount of PEEP during patient expiration. The V1 reservoir smooths out pressure variations caused by the pump. See Figure 2-21.

2.9.2 APL Bypass Valve Control

When the Fabius GS is operating in the automatic mode, the pneumatic assembly provides a vacuum signal to hold open the APL bypass valve in the breathing system. The V2 reservoir and filter provide noise damping, and the variable restrictor is used to set the vacuum level in the range of -150 to -240 cmH₂O.

When the machine is operating in the Manual mode, the pump on the pneumatic assembly (and the ventilator) is stopped, and the spring-loaded APL bypass valve in the breathing system closes, directing exhaled gas through the APL valve.

2.10 Electrical Block Diagram

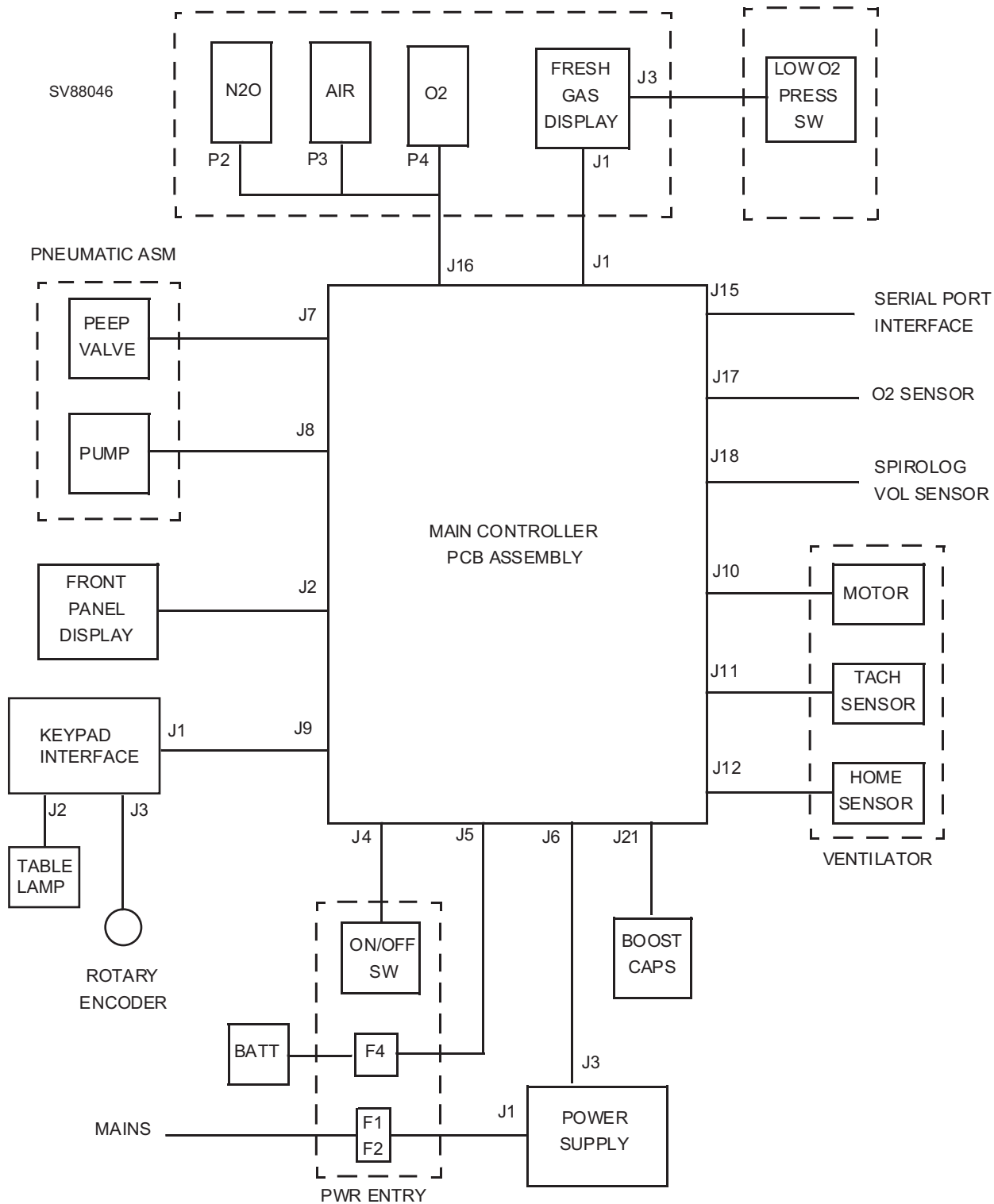

Figure 2-31. Electrical Block Diagram

2.11 Function Description: Control PCB

The control PCB provides the following functions in the Fabius GS:

2.11.1 Flowmeter

Receives flow rate data from the N₂O, Air, and O₂ flow sensors and provides fresh gas display information for these gases.

2.11.2 Patient Interface

Receives information from the oxygen sensor and processes it for display.

Receives flow information from the Spirolog sensor and processes it for display.

Converts airway breathing pressure to an electrical signal and processes it for display.

2.11.3 Ventilator

Provides ventilator motor drive, receives ventilator piston position and movement information. Provides ventilator pressure information.

2.11.4 Front Panel Functions

Provides power for the display panel and LED table lamp.

Provides video signals to the display.

Receives information from the keypad and rotary encoder for making display and operating selections, setting alarm limits, and service functions.

2.11.5 Pneumatic Assembly Control

Provides power to the pump on the pneumatic assembly.

Provides control signal to the electronic PEEP valve on the pneumatic assembly in response to operator setting.

Monitors pump vacuum to stabilize PEEP control.

2.11.6 Serial Port Interface

Provides isolated port for connecting external monitors and downloading software.

2.11.7 Battery

Provides charging current for battery and monitors state of battery charge.

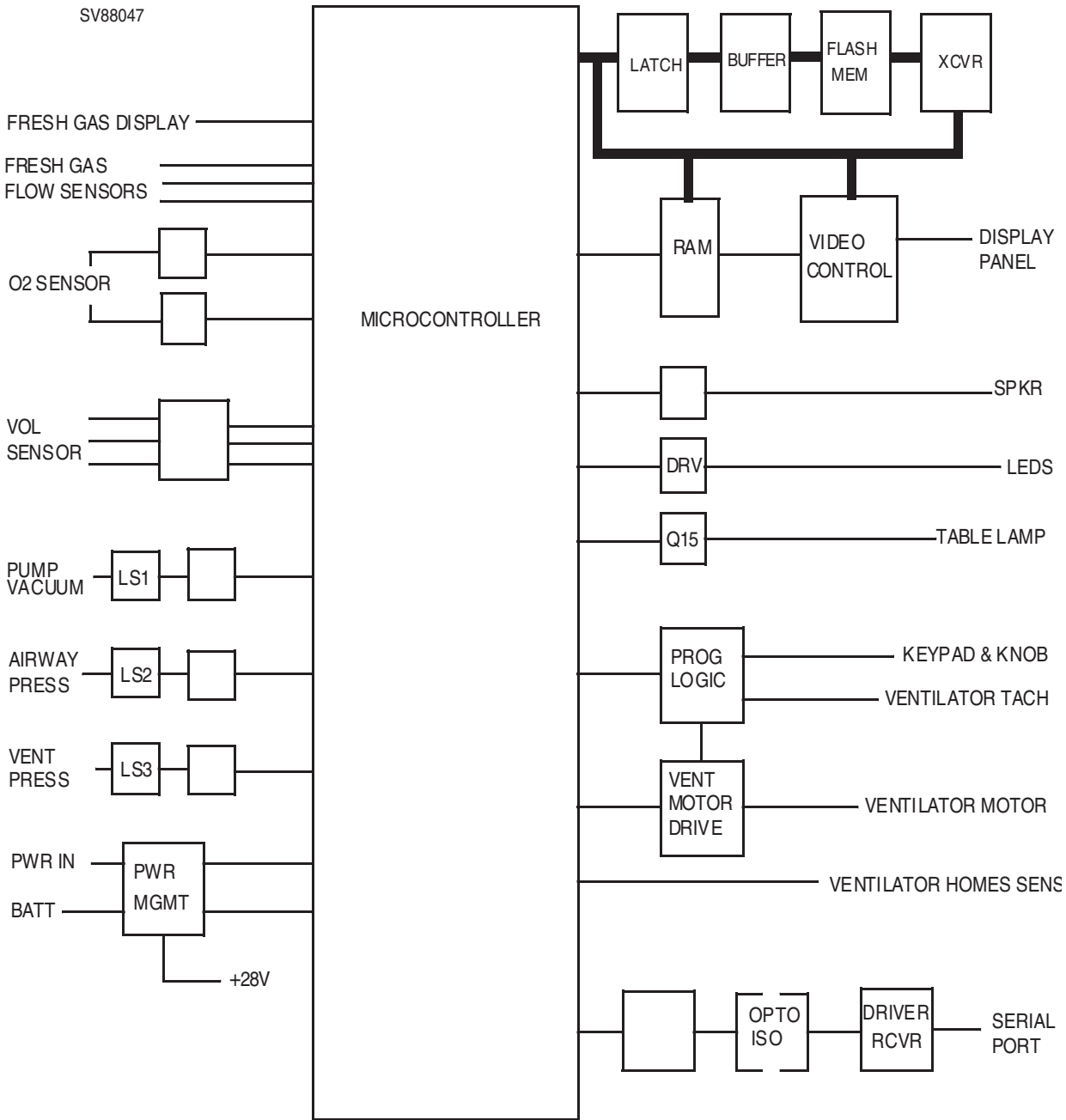

Figure 2-32. Controller Functional Block Diagram

2.12 Control Panel Assembly

The control panel assembly consists of a 320 x 240 pixel graphical display, a table lamp with six LEDs, a membrane keypad, rotary encoder and speaker.

Data and power for the display comes from the main controller PCB via a 20-conductor ribbon cable. The keypad interface is connected to the main controller PCB by a 30-conductor ribbon cable. A block diagram of the control panel assembly is shown in the following illustration.

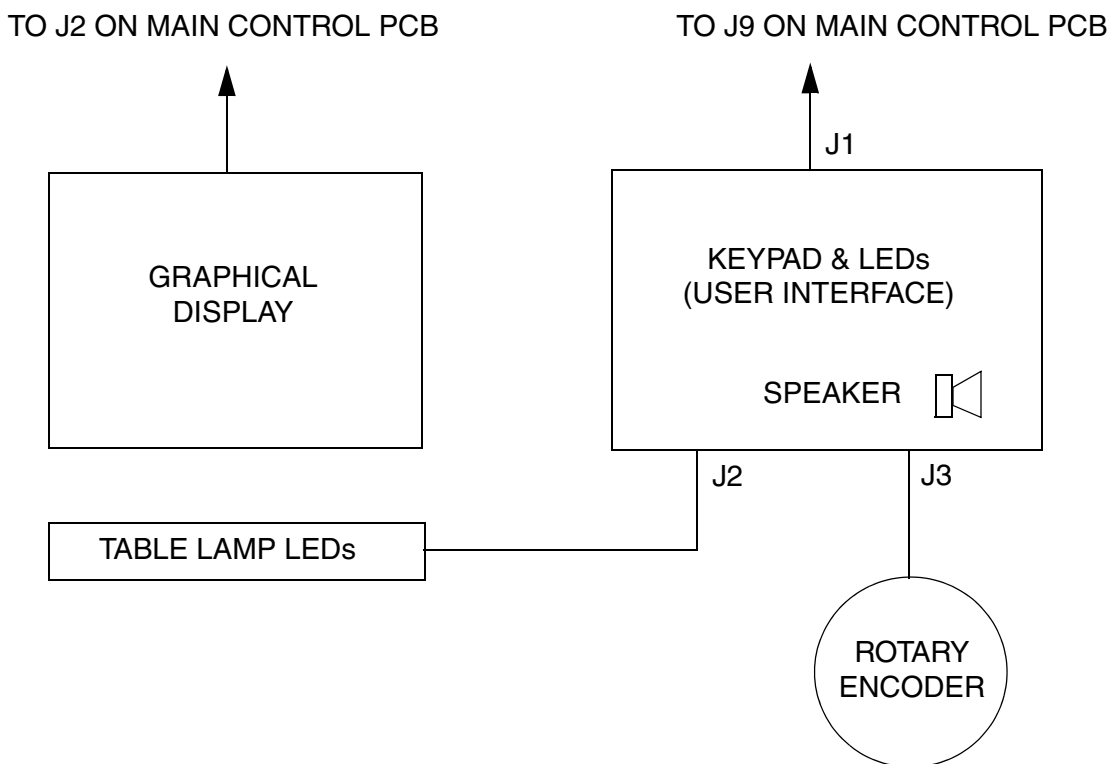

Figure 2-33. Control Panel Block diagram

An illustration of the control panel is shown on the next page.

Descriptions of the numbered items in the following illustration are given in the table below.

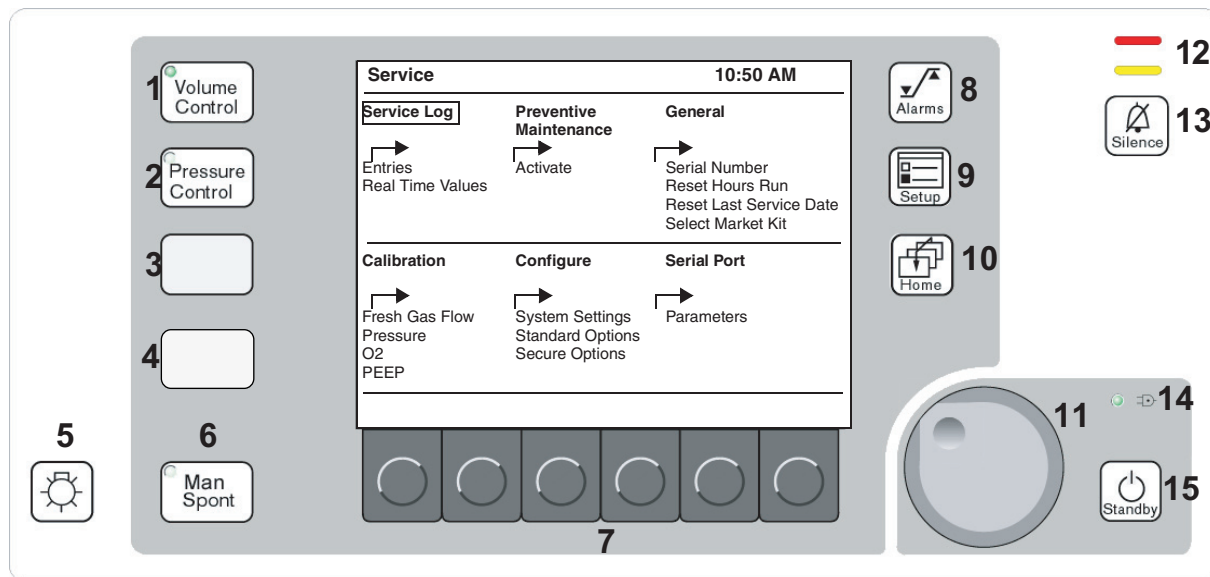

Figure 2-34. Fabius GS Control Panel (Main Service Screen Illustrated)

Item	Function
1	Selects volume controlled ventilation mode. Refer to Operator's Manual
2	Selects pressure controlled ventilation mode. Refer to Operator's Manual
3	Reserved for future use
4	Reserved for future use
5	Controls table lamp: Off/On
6	Places ventilator in Man Spont mode. Refer to Operator's Manual
7	Soft keys: activate the corresponding function that appears on screen above the key
8	For setting alarm limits. Refer to Operator's Manual
9	Setup key: activates sub-screens for monitoring functions. Refer to Operator's Manual
10	Home key: returns display to main screen shown before standby
11	Rotary control: moves the cursor on the screen; confirms selection when pressed
12	Alarm Status indicators: Flashing Red: Warning; Flashing Yellow: Caution; Solid Yellow: Advisory
13	Alarm Silence key: silences all active alarms for two minutes
14	Power ON indicator: lighted when machine is plugged into an active AC outlet
15	Returns unit to Standby mode

2.13 FiO₂ Measurement

The O₂ sensor measures the fraction of inspired O₂ (FiO₂) in the respiratory gas.

The O₂ sensor contains an alkaline electrolyte, a lead anode, two gold cathodes, and a Teflon membrane. The spatial separation of the two gold cathodes allows a voltage comparison to be made as explained below.

The O₂ sensor is an electrochemical cell that generates a voltage from the ion current.

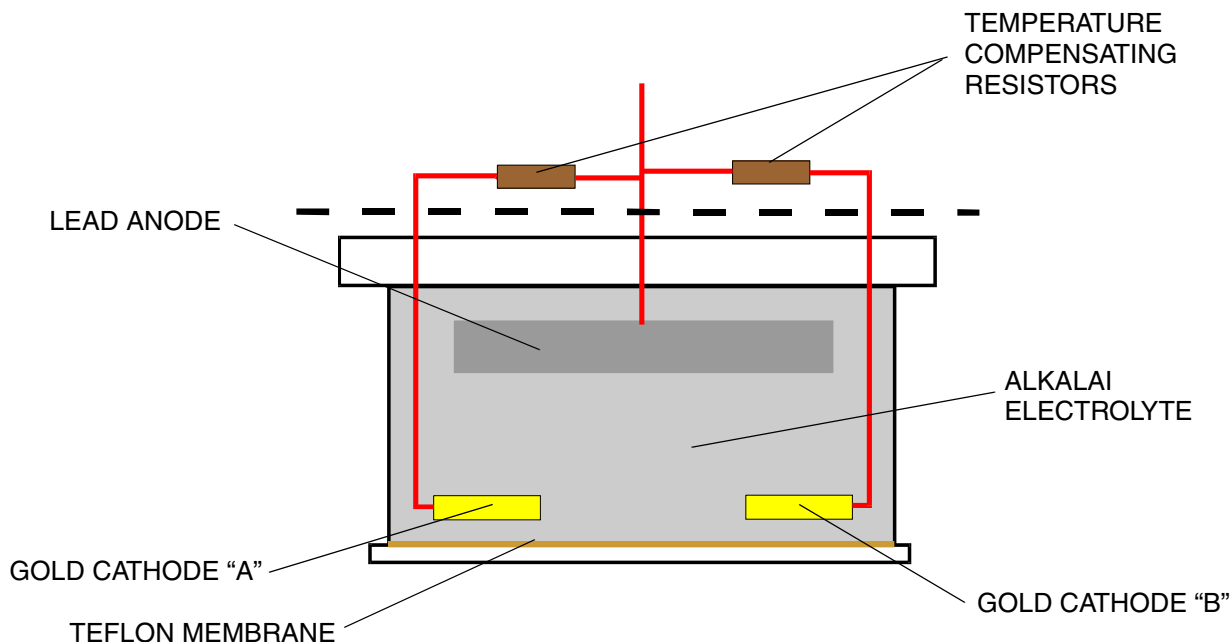

Figure 2-35. O₂ sensor

The O₂ to be measured diffuses through the Teflon membrane, reacts at the gold cathodes (negative polarity) and forms lead oxide and water at the lead anode (positive polarity). During this chemical process, a voltage is generated which is proportional to the O₂ partial pressure.

The internal resistance of the cell is determined by the surface area of the gold cathodes, the O₂ diffusion velocity, the distance between the gold cathodes and the lead anode. This resistance is approximately 700 ohms.

The chemical process is temperature-sensitive. Therefore temperature-sensitive resistors are connected in parallel with the O₂ sensor. These resistors and the internal resistance of the O₂ sensor correct the measuring voltage. Because two cathodes used in the O₂ sensor cell, two different voltages are generated. These voltages are compared with each other. If their difference exceeds a certain value, the machine prompts the operator to check the cell.

If the O₂ sensor fails, the control box will indicate an error on the graphics display.

2.14 Respiratory Flow Measurement

The flow sensor functions according to the constant temperature hot-wire anemometer principle. Respiratory gas flows past a thin platinum wire. This platinum wire (A) is located in a measuring tube and is electrically heated. The platinum wire is held at a constant temperature. Gas flow removes heat from the hot wire. The higher the gas flow rate, the greater the heat removal. The amount of electrical current needed to maintain a constant platinum wire temperature is thus proportional to the gas flow rate.

A second platinum wire (B) in the measuring tube is used to compensate for interferences from different gases present in the respiratory gas. The heat removed from the second platinum wire is measured during inspiration when the gas flow is zero.

The different gases present in the respiratory gas have a different thermal conductivity. The amount of heat removed from the second platinum wire is thus an indicator of respiratory gas composition.

Internal calibration tables for O₂/N₂O mixtures, Air and 100% O₂ are used to linearize the measured flow.

SV88037

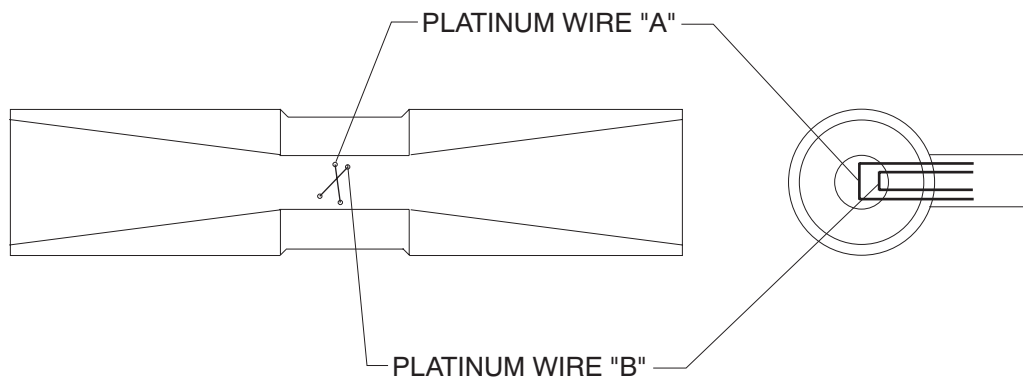

Figure 2-36. Respiratory Flow Sensor

2.15 Gas Flow Rate Measurement

The gas flow sensors operate on the principle of specific heat for individual gases. In each sensor, as the gas flows through a heated chamber the gas molecules carry away a certain amount of heat relative to the specific heat index for that gas.

A known amount of electrical current is required to maintain the temperature in the heated chamber. The higher the gas flow rate, the more heat is removed from the chamber and more current is required to maintain the temperature in the chamber. This current is then scaled and displayed as liters per minute flow rate for each gas.

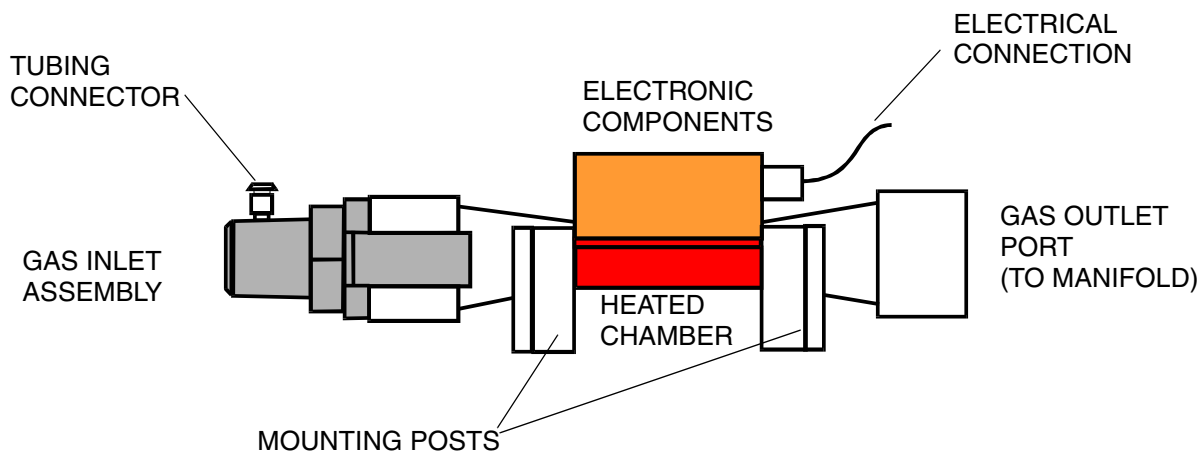

Figure 2-37. Flow Sensor Details

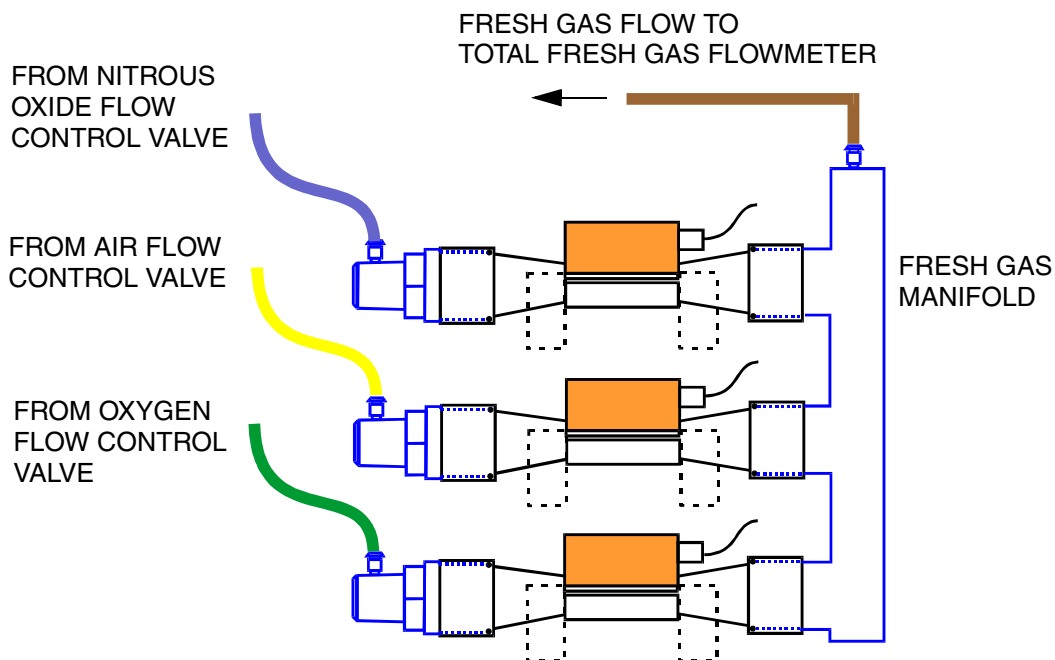

Figure 2-38. Flow of Gases Through Sensors

2.16 Vaporizer

Refer to separate technical documentation of the anesthetic vaporizer.

[RETURN TO THIS MANUAL'S TABLE OF CONTENTS](#)
[RETURN TO CD-ROM TABLE OF CONTENTS](#)

3.0 TROUBLESHOOTING

This section contains information to assist the Draeger qualified Service Representative in locating electrical faults affecting operation of the Fabius GS. A simplified electrical block diagram is given in Figure 3-1. Since most troubleshooting efforts begin with verifying power supply voltages, the following paragraph outlines the voltage distribution scheme within the machine along with test points for each of the voltages.

A piping diagram (Figure 3-4) and a pneumatic control diagram (Figure 3-5) are also included in this section.

3.1 Power Supply and Voltage Distribution

In the Fabius GS, the power supply delivers 28 VDC to the main controller unit PCB assembly. Some of the other voltages derived on this assembly can be measured at the connectors listed in Table 3-1. Fuse data is listed in Table 3-2. Controller PCB connector locations are shown in Figure 3-2.

Table 3-1: Test Points and Allowable Ranges

CONTROLLER PCB	FUNCTION	ACCEPTABLE RANGE
J6-1, + 28 VDC	Power In	26.6 VDC to 29.4 VDC
J6-4, Common		
J1-1, + 5 VDC	Fresh Gas Display	4.75 VDC to 5.25 VDC
J1-14, Common		
J2-1, +12 VDC	Front Panel Display	11.5 VDC to 12.5 VDC
J2-20, Common		
J16-1, +10 VDC	Fresh Gas Flow Sensors	9.99 VDC to 10.01 VDC
J16-9, Common		

Table 3-2: Fuse Data

Fuse	Rating	Location	Function
External	2.5A, T	Power Entry	Mains
F4	3.15A	Power Entry	Battery
F1	4.0A, T	Controller PCB	Battery
F2	2.5A, T	Controller PCB	+28V dist
F3	1.6A, T	Controller PCB	+28V dist

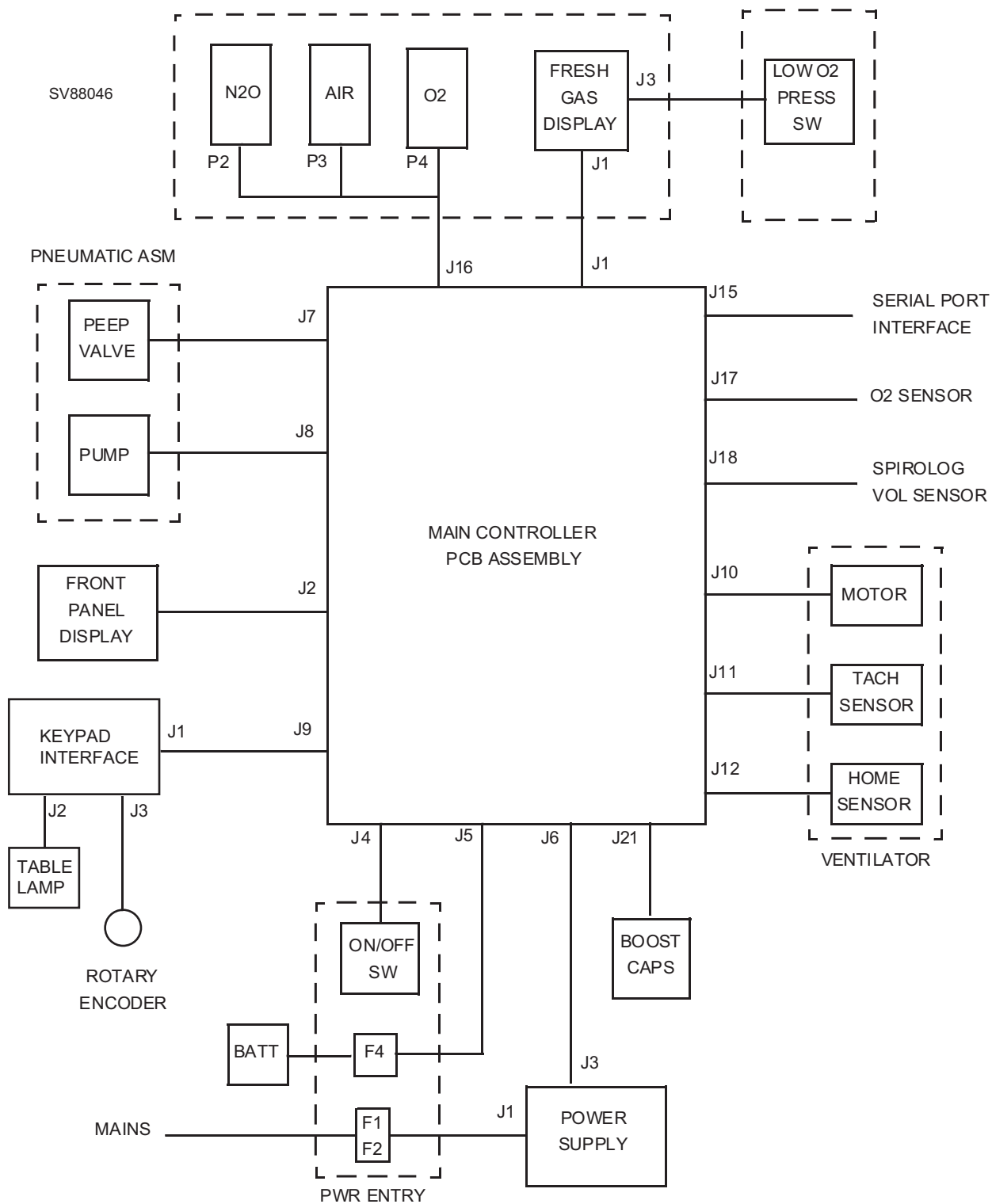

FIGURE 3-1. Fabius GS Block Diagram (Electrical)

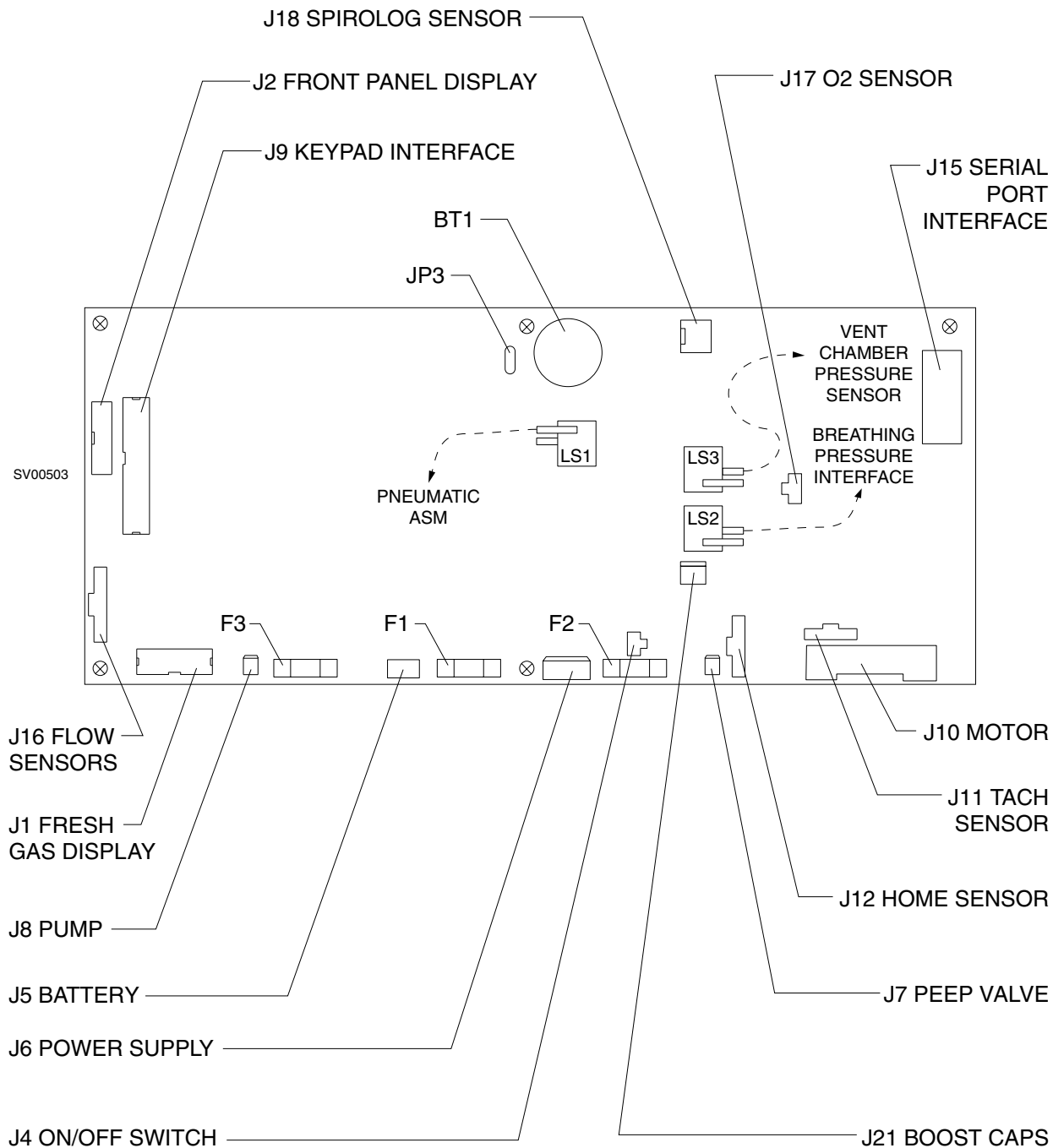

FIGURE 3-2. Main Controller PCB Connector Locations (P/N 4116632)

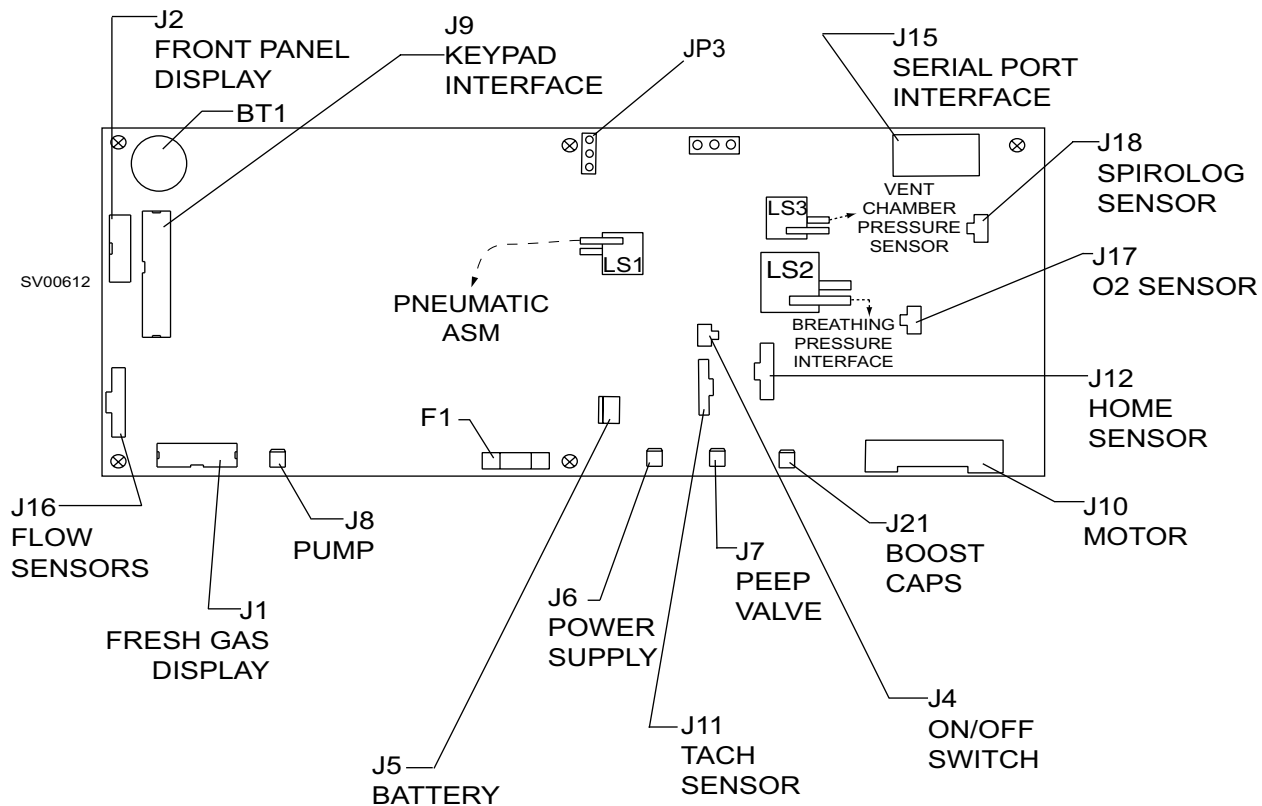

FIGURE 3-3. Main Controller PCB Connector Locations (P/N 4118079)

SV00454

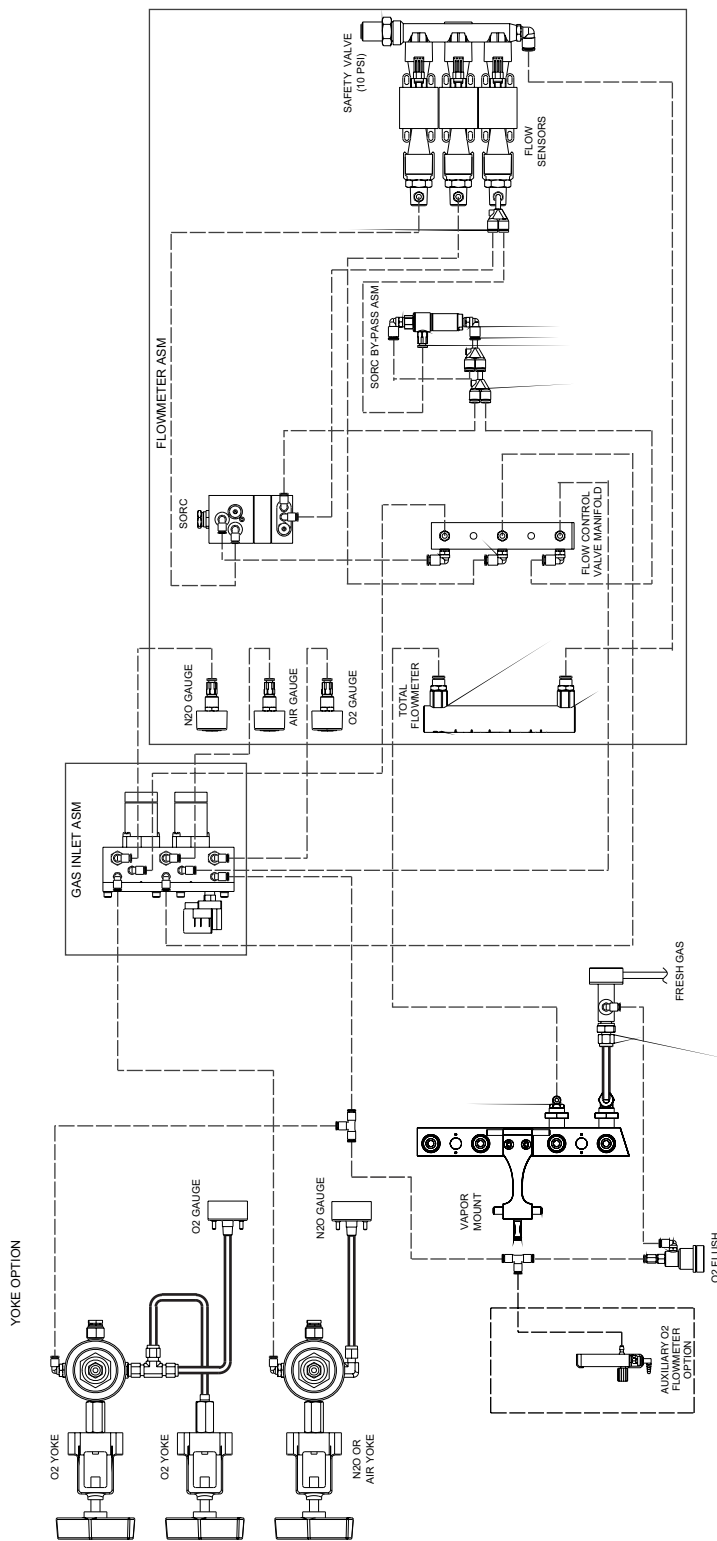

FIGURE 3-4. Fabius GS Piping Diagram

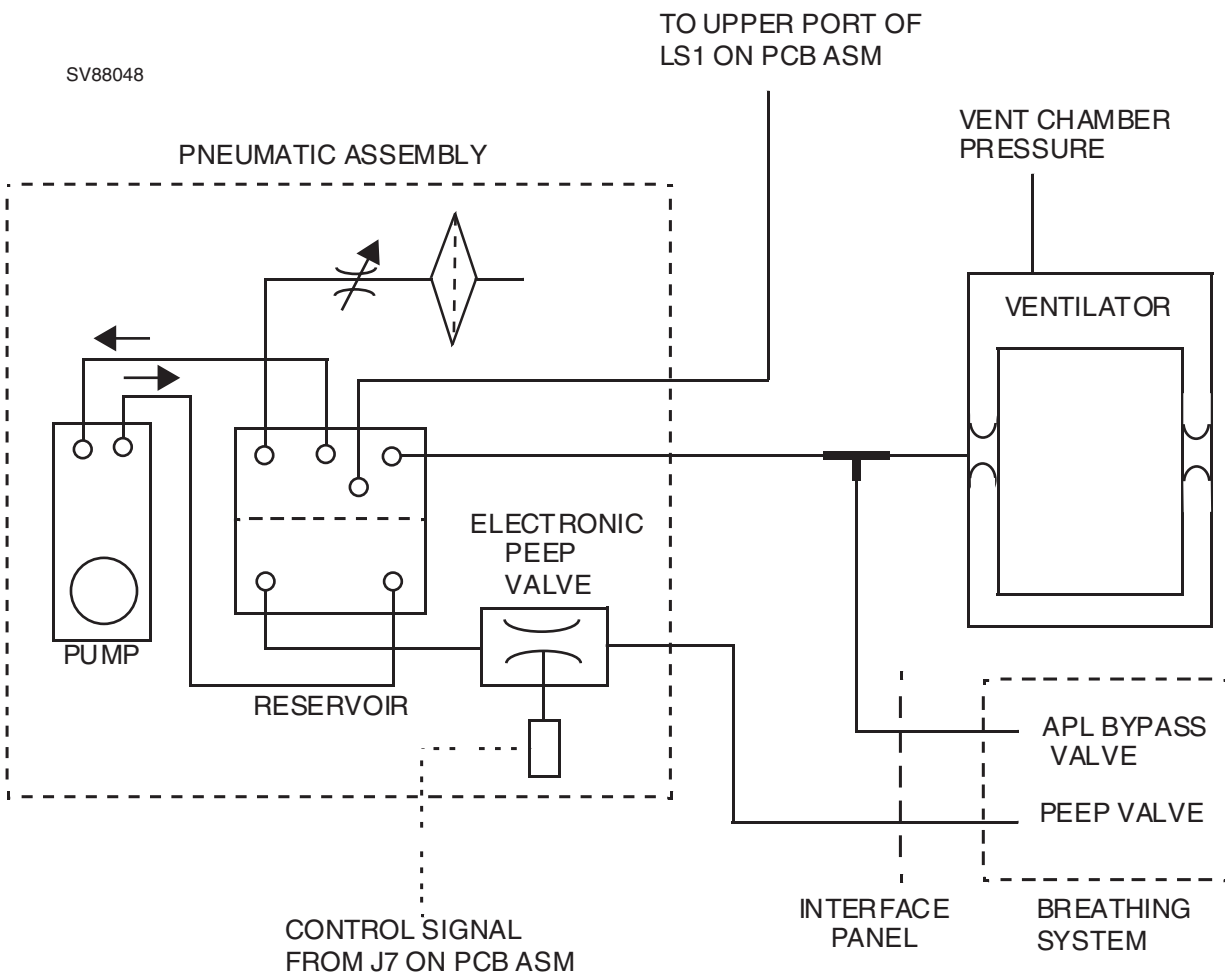

FIGURE 3-5. Fabius GS Pneumatic Control Diagram

3.2 Battery

The Fabius GS backup battery comprises two series-connected 12 V rechargeable batteries. While the machine is operating from AC, the total battery voltage at full charge should be within the range of 27.0 to 29.6 V. Battery voltage can be measured at J5 on the main controller PCB assembly. During battery operation, the low battery cutoff voltage should be within the range of 21.0 to 20.0 V.

3.3 Troubleshooting Guides

Table 3-3 lists common failure modes and symptoms (excluding simultaneous multiple faults) for the monitoring and display devices in the Fabius GS. Each failure mode or symptom is keyed to a troubleshooting guide flow chart at the back of this section to assist the service representative in locating the cause of a problem. These flow charts assume that the machine is plugged into an AC outlet with the correct voltage, and the machine is not running on its backup battery.

Table 3-3: Fabius GS Failure Mode and Symptom List

FAILURE MODE / SYMPTOM	CORRECTIVE ACTION
Loss of O2 Monitor	GUIDE 1:
Loss of Breathing Pressure Monitor	GUIDE 2:
Loss of Respiratory Volume Monitor	GUIDE 3:
No Audio Alarms	GUIDE 4:
Serial Port Communication failure	GUIDE 5:
No Oxygen Supply Pressure Alarms	GUIDE 6:
Display Blank Upon System Power-up	GUIDE 7:
Keypad Inoperative	GUIDE 8:
Ventilator Inoperative	GUIDE 9:
Fresh Gas Display Blank or Not Working Properly	GUIDE 10:

GUIDE 1: Loss of O₂ Monitor

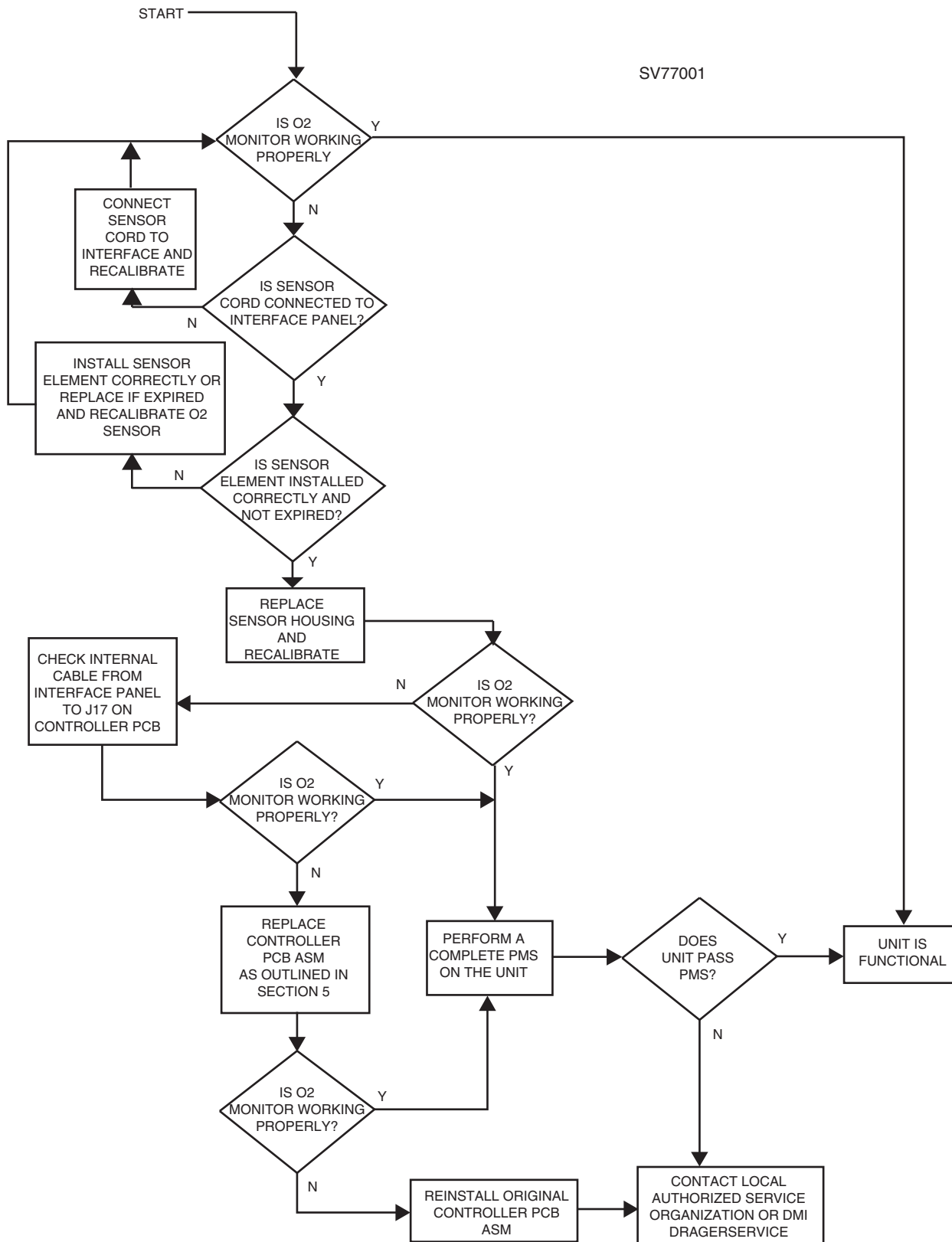

GUIDE 2: Loss of Breathing Pressure Monitor

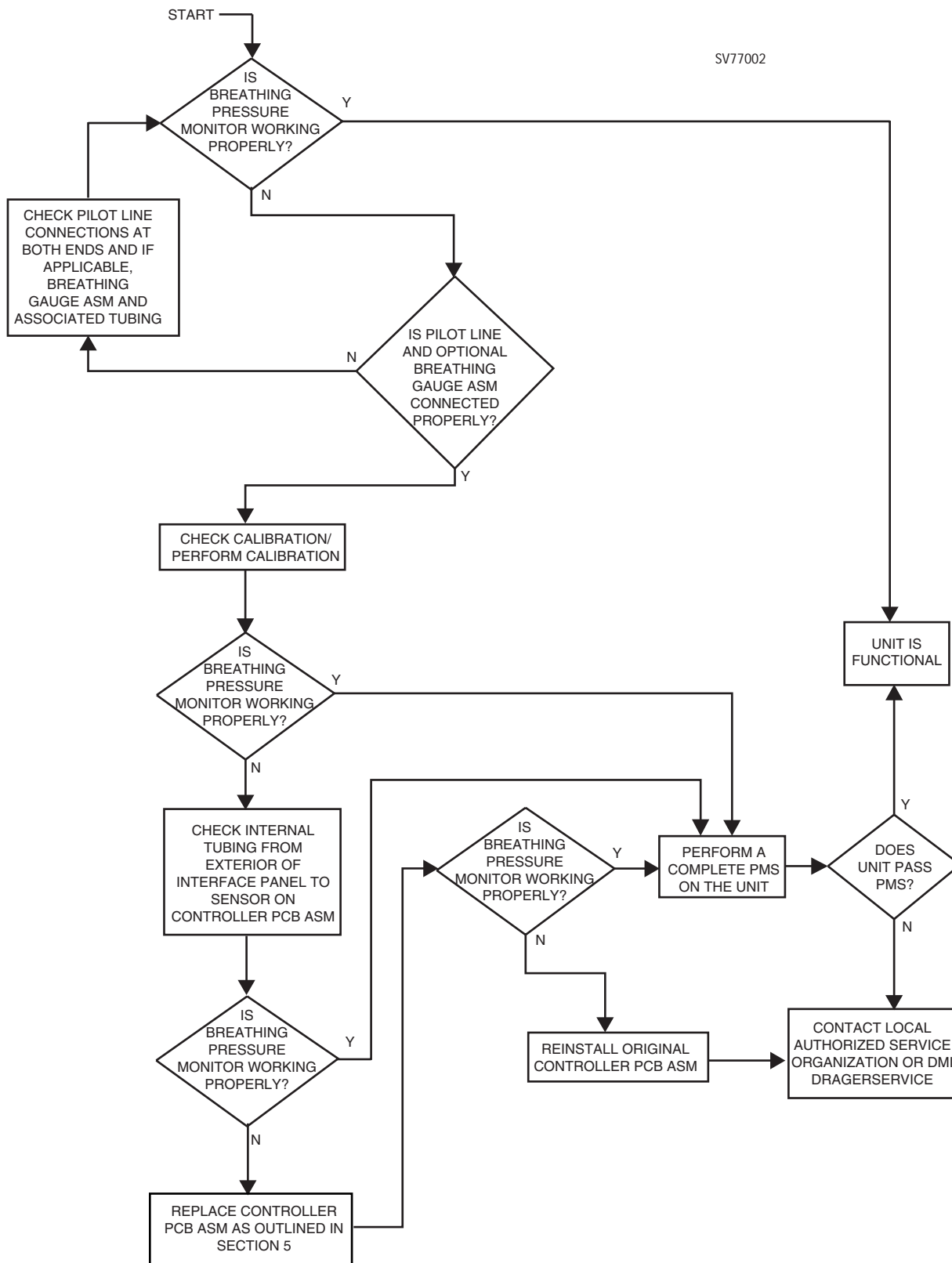

GUIDE 3: Loss of Respiratory Volume Monitor

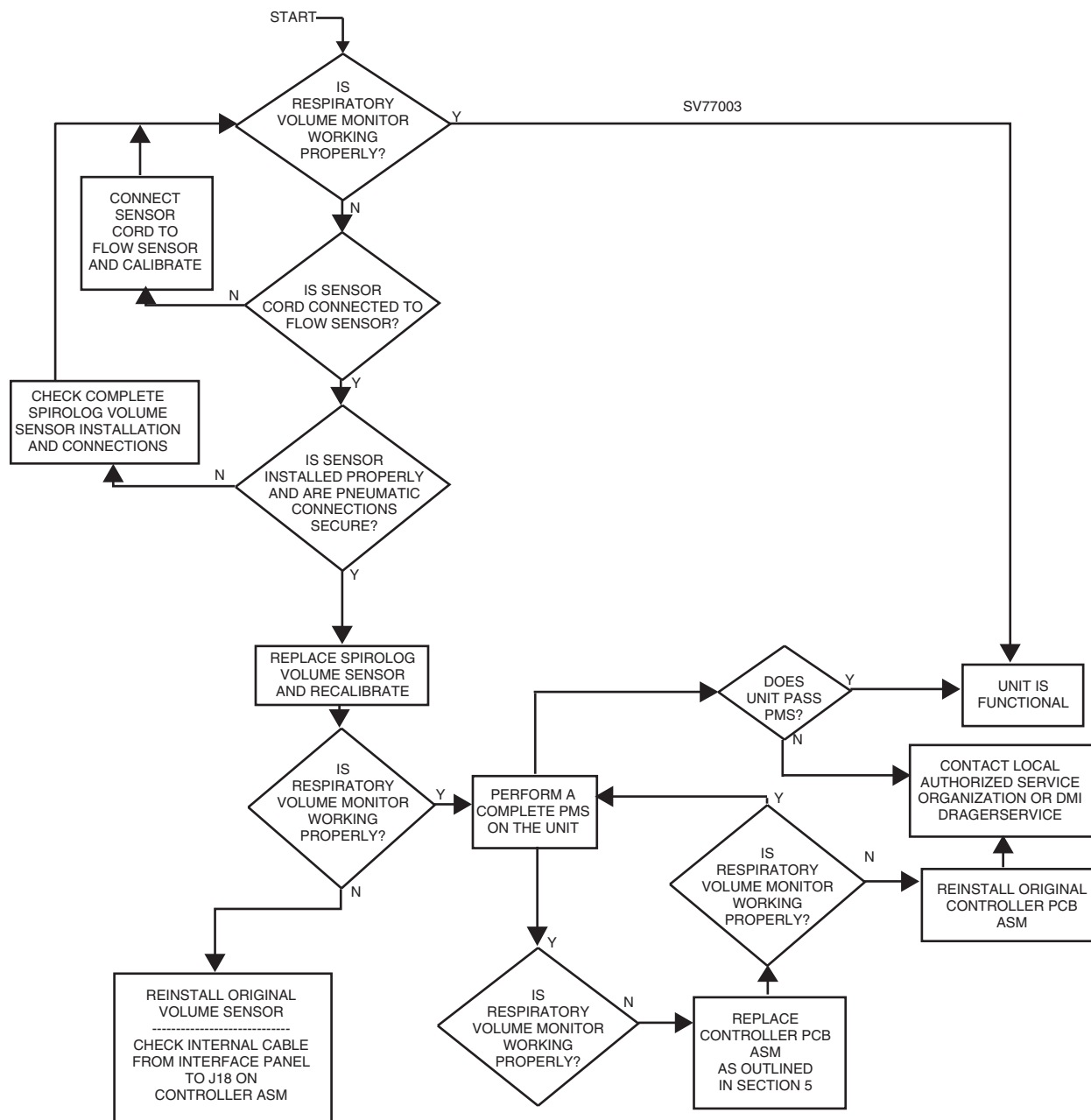

GUIDE 4: No Audio Alarms

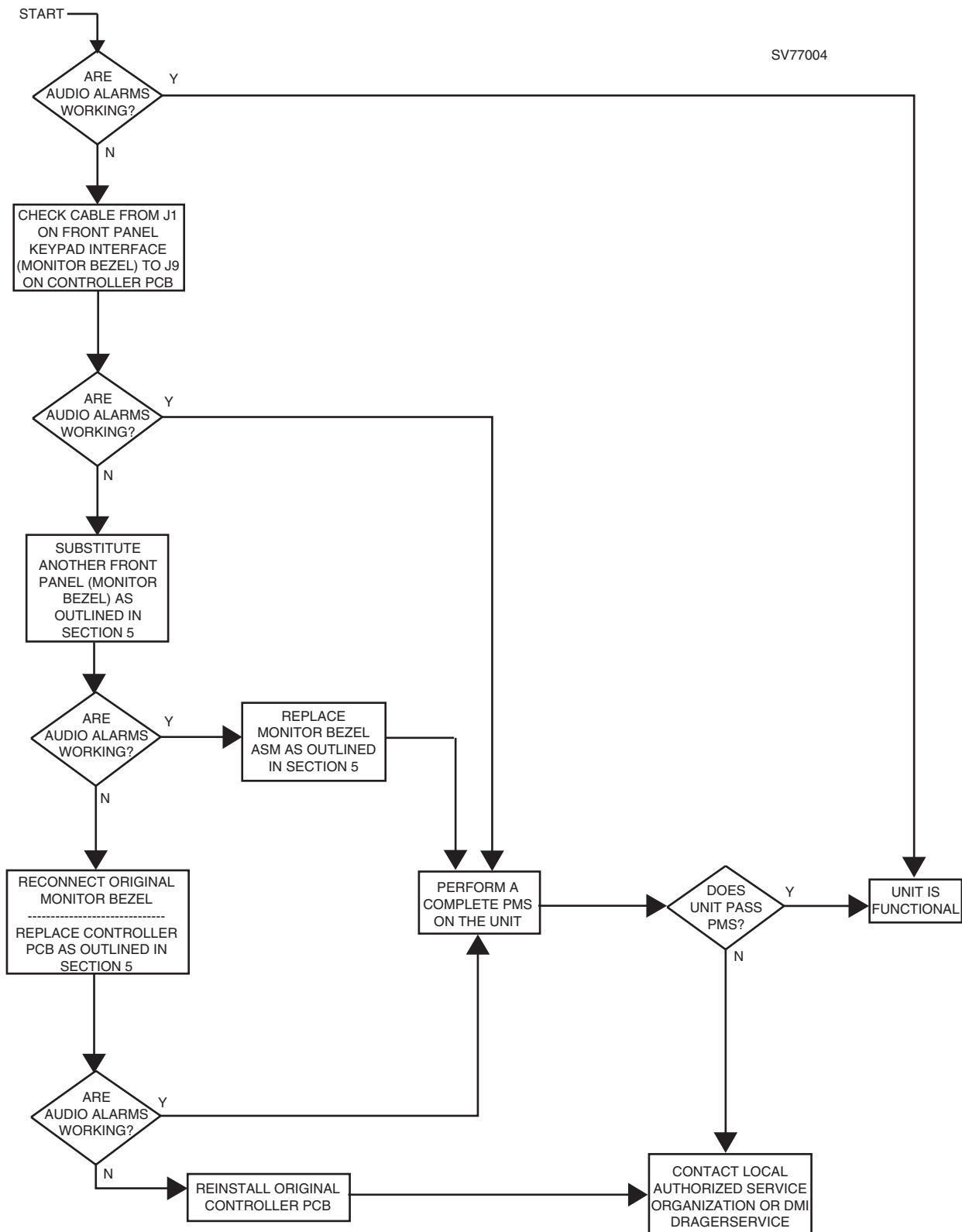

GUIDE 5: Serial Port Communication Failure

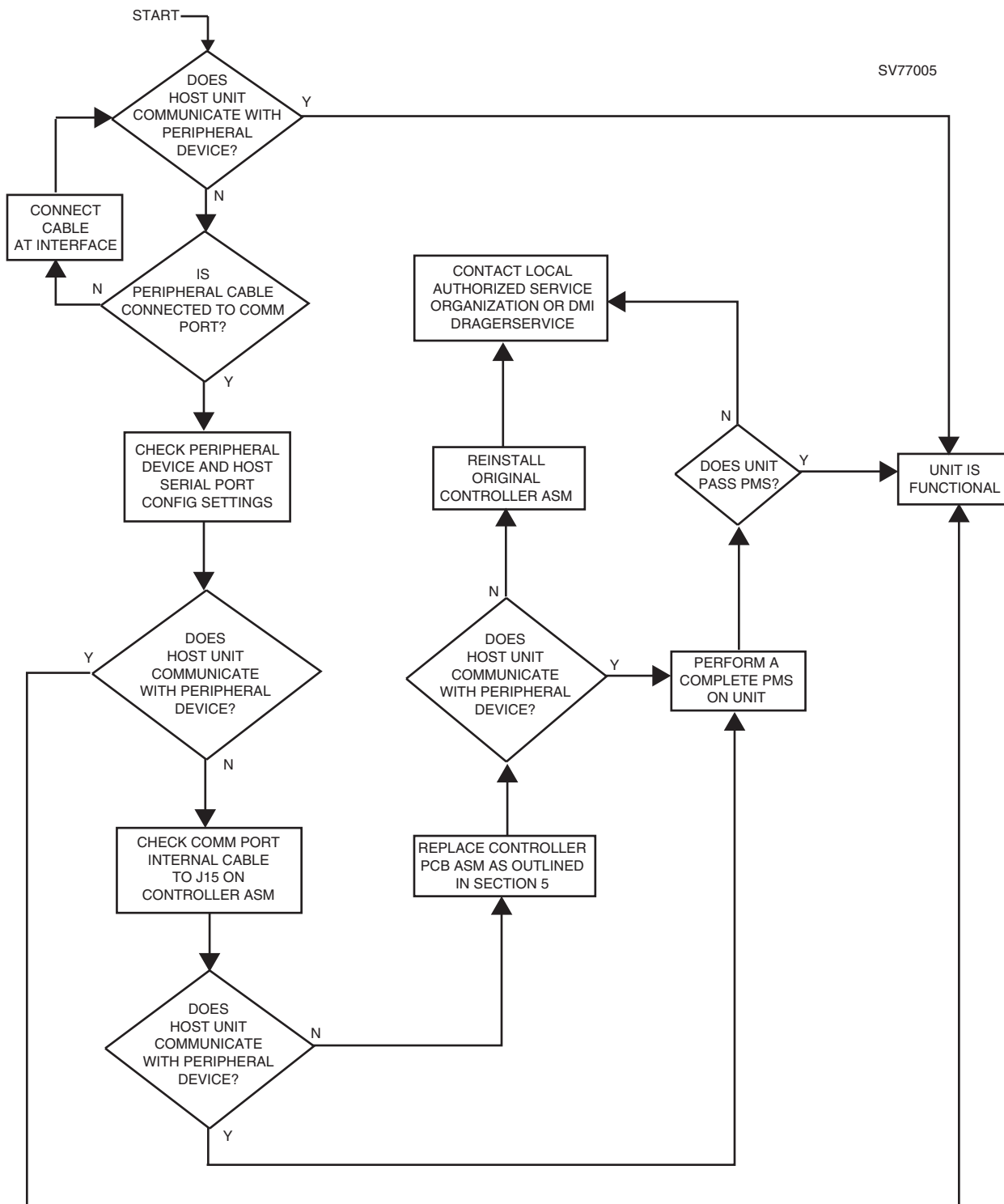

GUIDE 6: No O₂ Supply Pressure Alarms

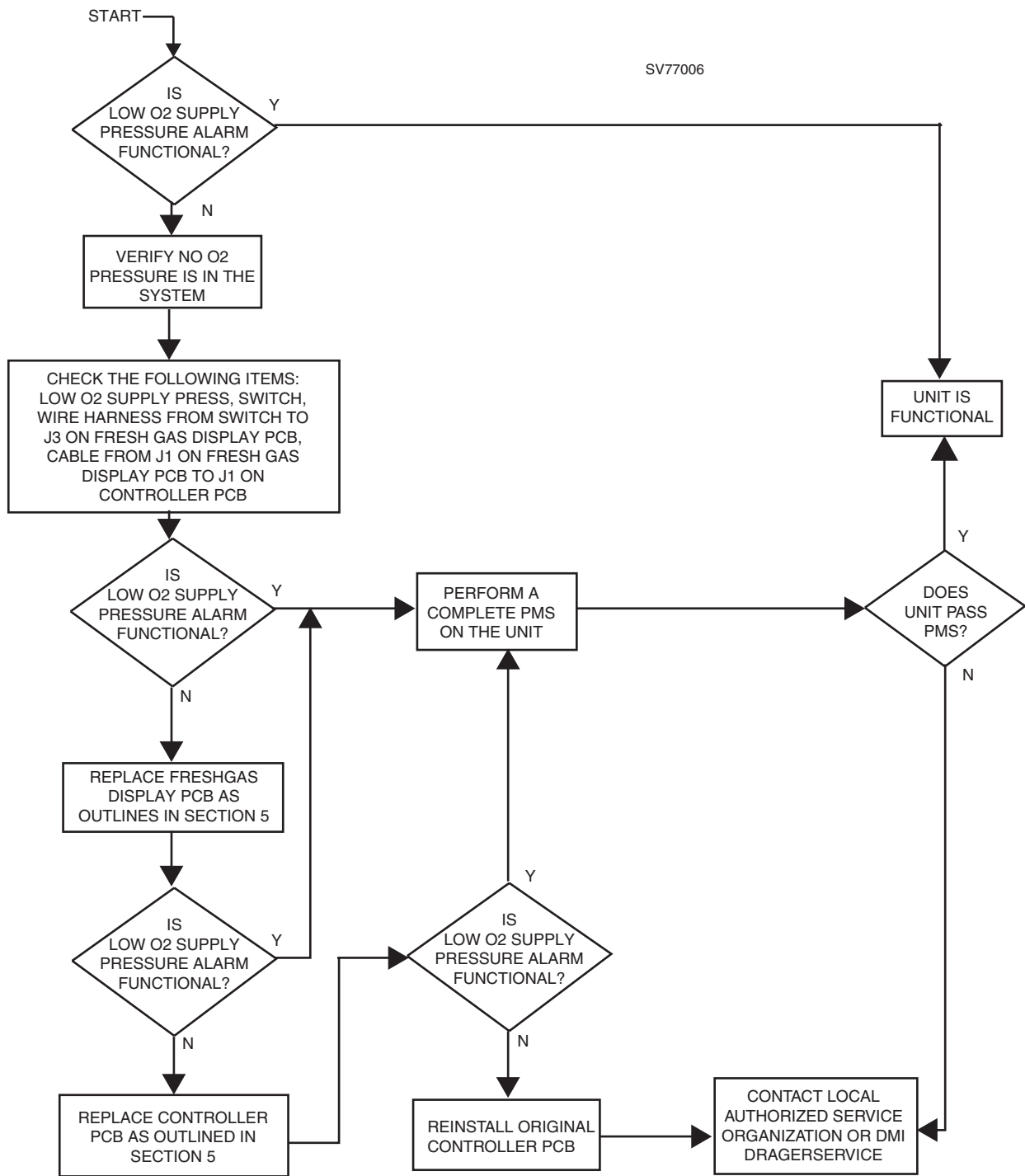

GUIDE 7: Main Display Blank Upon System Power-up

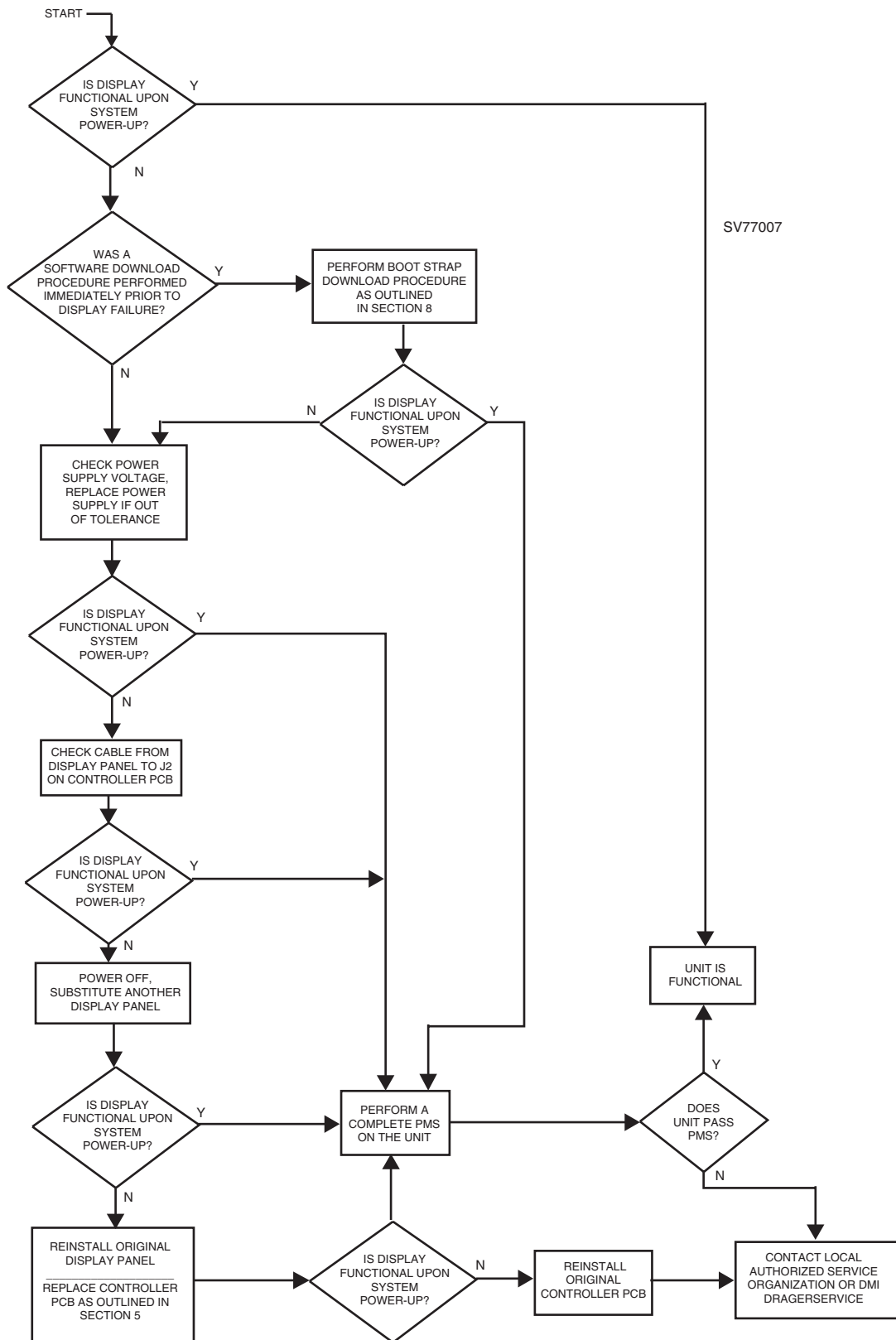

GUIDE 8: Keypad Inoperative

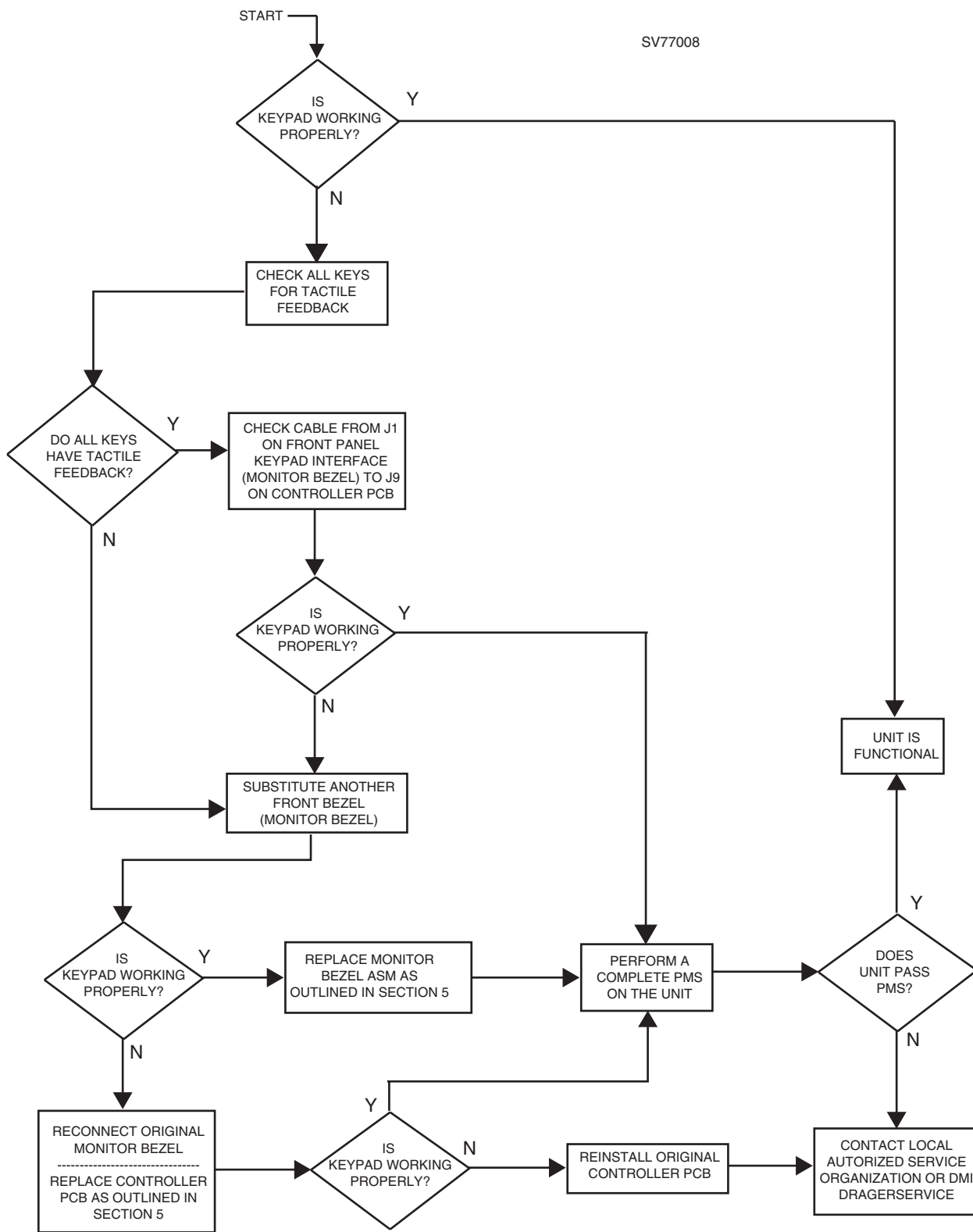

GUIDE 9: Ventilator Inoperative

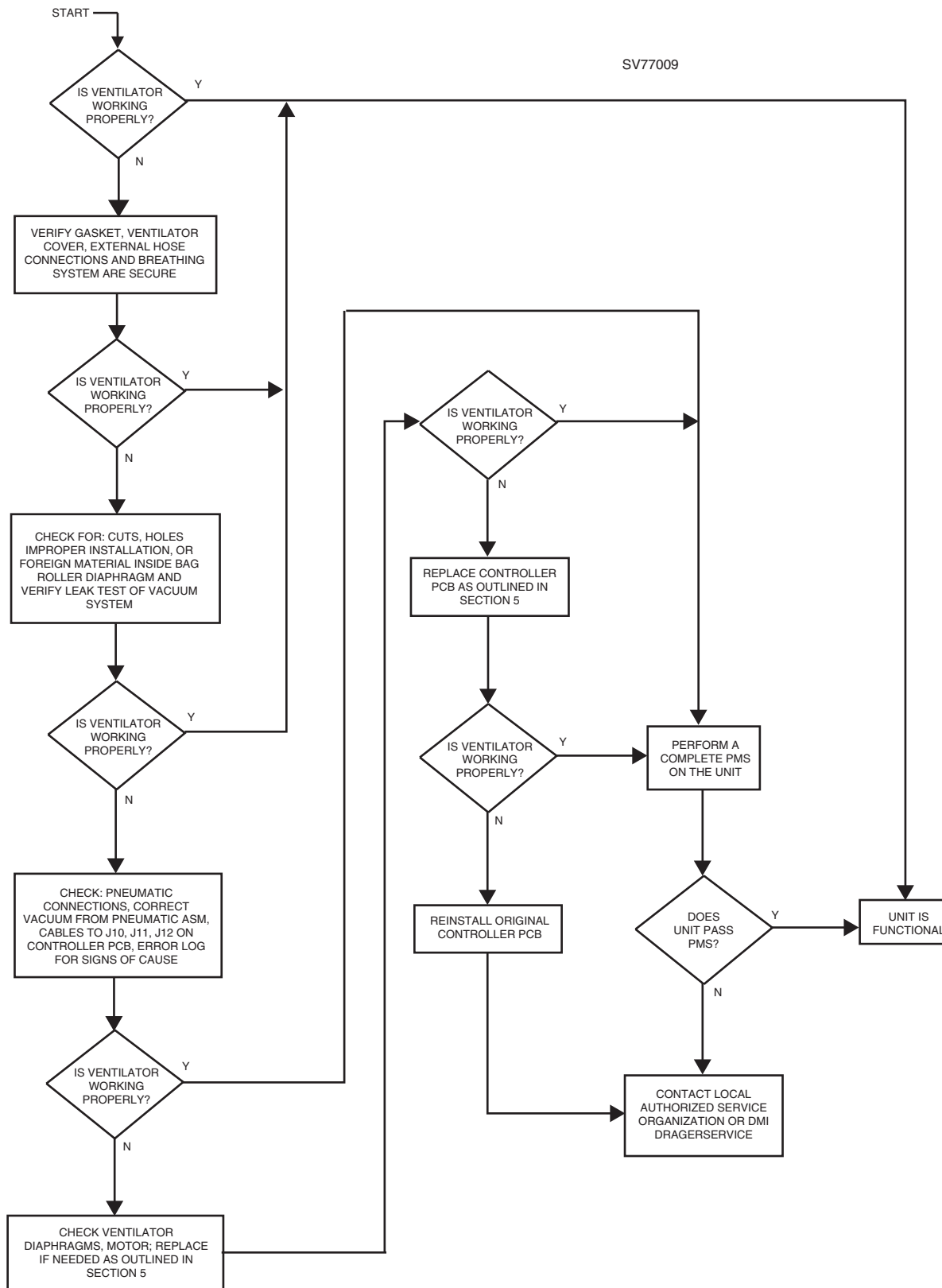

GUIDE 10: Fresh Gas Display Blank or Not Working Properly

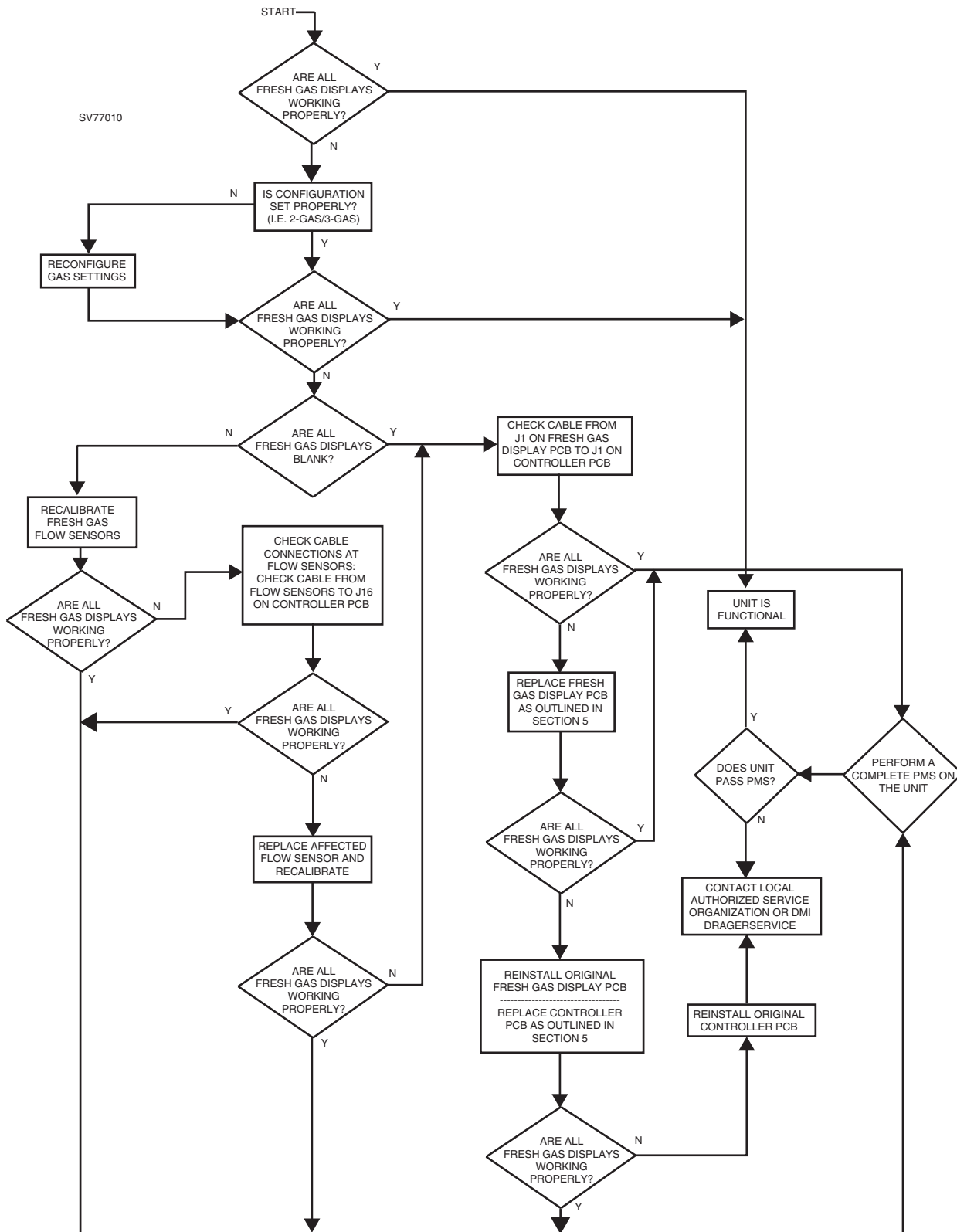

[RETURN TO THIS MANUAL'S TABLE OF CONTENTS](#)
[RETURN TO CD-ROM TABLE OF CONTENTS](#)

4.0 DIAGNOSTICS

NOTE: The screen illustrations contained in this section are for reference only and therefore may or may not reflect the software version currently installed.

The Fabius Tiro diagnostic system monitors and records the status of its internal hardware when the machine is turned on. The status of each test is displayed on the Power-up screen as shown in [Figure 4-1](#). This screen is displayed for several seconds before proceeding to the Standby screen. The power-up screen also displays one of three messages at completion of the diagnostics:

FUNCTIONAL:	This message indicates that the Fabius GS has passed all power-up tests and is fully functional. The machine will proceed to the Standby screen (Figure 4-2 .) after a short delay.
CONDITIONALLY FUNCTIONAL:	This message indicates that a minor problem has been detected. The Fabius GS may be used, but your local authorized service organization or DrägerService should be notified to correct the problem. Press the rotary control to proceed to the Standby screen.
NON-FUNCTIONAL:	This message indicates that a serious problem has been detected, and the machine will not proceed to the Monitor screen. Do not use the machine. Immediately notify your local Authorized Service Organization or DrägerService to correct the problem.

The following quick reference tree is for use in quickly locating the Service Screens necessary to perform specific functions within the software. The indentions shown below indicates the relationship of the Service Screen/function relative to the location of each Service Screen within the software.

SERVICE ACCESS SCREEN	ENTRIES/ACTIONS
(4.3) Service Log:	
Entries	Clear Service Log
Real Time Entries	Displays current data values and data
(4.4) Preventative Maintenance	
	Month/Day/Year
(4.5) General:	
Serial Number	8 digit serial number
Reset Hours Run	Yes/No
Reset Last Service Date	Yes/No
Select Market Kit	U.S./Non-U.S.
(4.6) Calibration:	
Fresh Gas Flow	Store zero/Exit
Pressure	Store zero/Exit
O2	Store zero/Exit
PEEP	Calibrate/Exit
(4.7) Configure:	
Model Type	Fabius GS/Tiro
Standard Options:	
Flowmeter:	
O2 Position	Left/Right
Gas Selection	2 Gas/3-Gas
Flowtube Resolution	Normal/High Res
O2 Whistle:	
Change State	Enable/Disable
Alarms:	
No Fresh Gas	Enable/Disable
Fresh Gas Low	Enable/Disable
Threshold Low	Enable/Disable
Pressure:	
Ambient Pressure	Adjust
Plateau/Mean Display	Change display
Secure Options	Enable/Disable
(4.8) Serial Port:	
Parameters:	
Baud Rate	1200, 2400, 4800, 9600, 19200, 38400
Parity	NONE/EVEN/ODD
Stop Bits	1,2
Data Bits	7,8
Protocol	VITALINK/MEDIBUS

The Preventive Maintenance Due message will appear on the screen if the current date exceeds the Periodic Manufacturer's Service due date stored in the machine.

SYSTEM DIAGNOSTICS	System Status
Watch Dog	Pass <input style="width: 50px; height: 15px;" type="checkbox"/>
System RAM	Pass
Program Memory	Pass
Video Test	Pass
Interrupts	Pass
A/D Converter	Pass
NV RAM	Pass
Serial Port	Pass
Clock	Pass
Speaker	Pass
Main Power	Pass
Battery	Pass
 Fabius GS SW XXX CRC XXX	

Figure 4-1. Power-up Diagnostics Screen

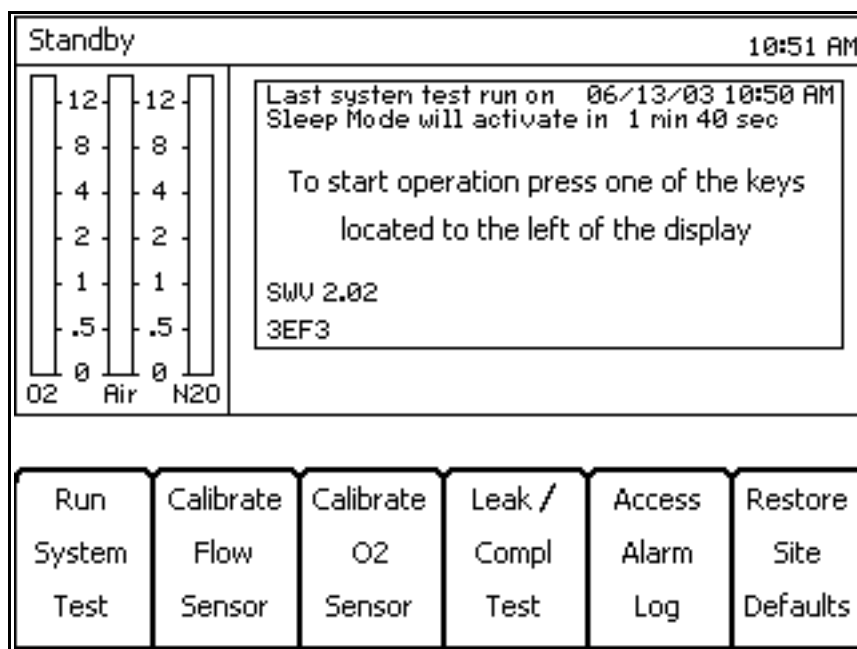



Figure 4-2. Standby Screen

Further diagnostic functions are available through service screens that can be called up at the display panel. The following paragraphs provide a description of each service screen that can be accessed at the display. If no display is present upon system power-up, refer to Section 3.0 of this manual for troubleshooting assistance.

NOTE: During display of the Standby screen, a five minute count-down appears on the screen, after which the display changes to a Sleep Mode. Press any key on the panel to return to the Standby screen.

To access the System Service screen, press and hold the  and  keys, and press the rotary knob.

4.1 System Service Screen

The System Service Screen shown in [Figure 4-3](#). displays system service data.

Press the rotary knob to go to the Main Service screen.

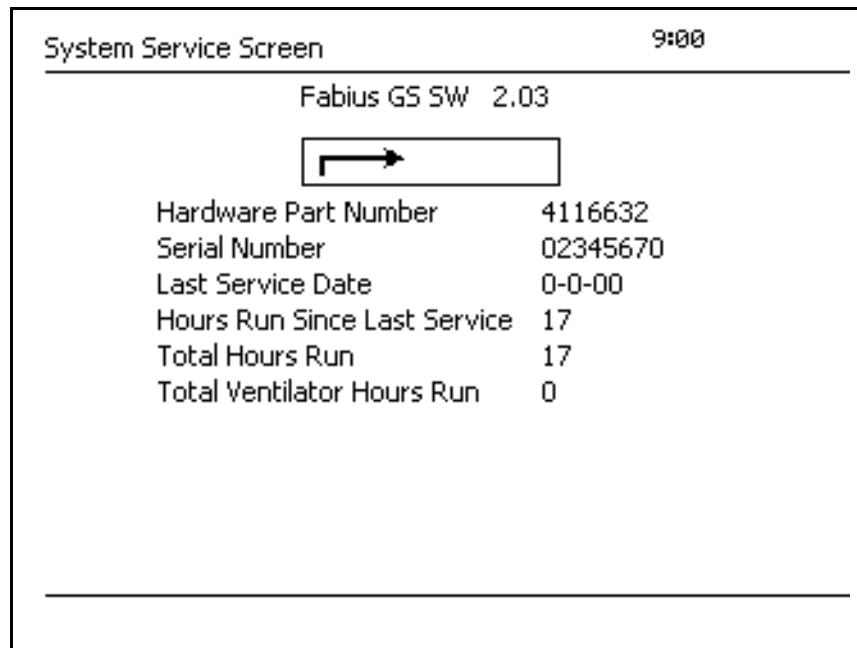



Figure 4-3. System Service Screen

4.2 Main Service Screen

The Main Service Screen shown in [Figure 4-4](#), lists the service functions available under each of the displayed categories.

Turn the rotary knob to move the scroll box to the desired category, then press the knob to confirm. The Service Log category is illustrated.

If desired, press the  key to return to the standby screen.

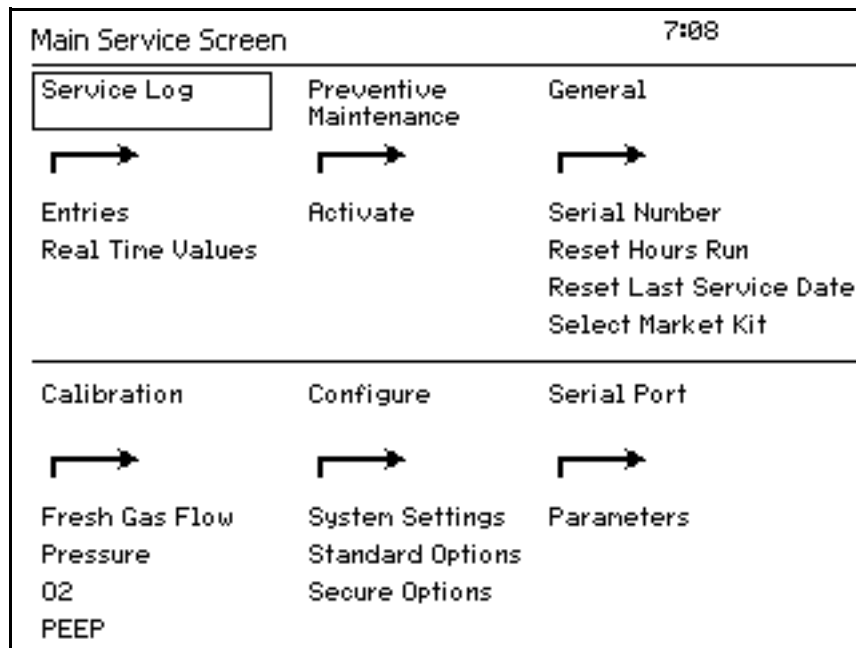

Figure 4-4. Main Service Screen

4.3 Service Log

When the Service Log category is selected, the screen shown in [Figure 4-5](#) will appear.

Turn the rotary knob to scroll down to select the desired function, then press the knob to confirm. The service log screens are described in the following pages.

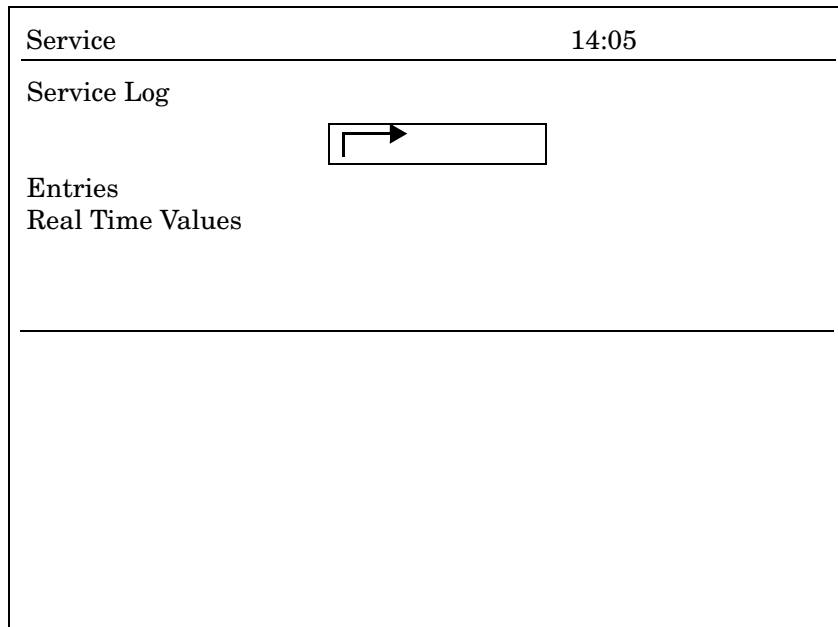
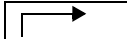

Figure 4-5. Service Log Category Selected

To return to the main service screen, scroll to the  and press the rotary knob to confirm.

4.3.1 Service Log Entries

When Entries is selected, the screen shown in [Figure 4-6](#). appears.

Use the rotary knob to scroll through the list of service log entries. The service log holds up to 256 entries. When new entries are made, the oldest entries are replaced with the new entries. The most recent entries appear upon screen call-up.

CAUTION: Selecting Clear Service Log and pressing the knob will bring up another screen that allows you to delete all entries. Selecting YES will delete all entries.



Service		11:30	
Service Log			
 Clear Service Log			
Date	Time	Code	Description
06-13-03	15:00	V043	MOTOR LIM STOP
06-13-03	12:46	V043	MOTOR LIM STOP
06-13-03	12:46	V043	MOTOR LIM STOP
06-13-03	11:33	V044 98	MEMBRANE PRES LOW
06-13-03	11:32	V045 271	MEMBRANE PRES HIGH
06-13-03	11:32	V044 98	MEMBRANE PRES LOW
06-13-03	11:31	V044 97	MEMBRANE PRES LOW

Figure 4-6. Service Log Entries Screen

Tables of service log entries, error codes and their descriptions begin on the next page.

Scroll to the  and press the rotary knob to return to the Service Log category screen.

FABIUS GS	DIAGNOSTICS (continued)
------------------	--------------------------------

Fabius GS Service Log Entries:

Table 4-1: Communication Errors		
Code	Description	Possible Cause
C001	Handler Busy	Bad processor, external device incorrect operation
C002	Incoming Overflow	Bad processor, bad cable or connector, incorrect settings, external device incorrect operation
C003	Outgoing queue overflow	Bad processor, external device incorrect operation
C004	Message not registered	External communications error
C005	Character not transmitted	Bad processor, external device incorrect operation
C006	Interrupt problem	Bad processor
C007	Continuous interrupts	Bad processor
C008	Excessive Breaks	Bad processor, incorrect settings, external device incorrect operation
C009	Excessive Framing	Bad processor, incorrect settings, external device incorrect operation
C010	Excessive Parity	Bad processor, incorrect settings, external device incorrect operation
C011	Excessive Overrun	Bad processor, incorrect settings, external device incorrect operation
C012	Non-existent UART	Bad processor

Table 4-2: Monitor Errors		
Code	Description	Possible Cause
M001	O2 <10%	O2 cell not working properly
M002	O2 LOW INOP	O2 cell inoperative or disconnected
M003	O2 DIFF HIGH	Difference between Cell A and Cell B >25%
M004	BATTERY <10%	Battery level below 10% of capacity while operating without mains power
M005	BATTERY <20%	Battery level below 20% of capacity while operating without mains power
FG01	N2O CAL ERR	N2O sensor value out of range
FG02	AIR CAL ERR	AIR sensor value out of range
FG03	O2 CAL ERR	O2 sensor value out of range

Table 4-3: Diagnostic Errors		
Code	Description	Possible Cause
F001	Diag Watchdog	Bad hardware
F002	Diag System Ram	System RAM fails on pwr up, bad RAM chip, bad CPU, bad trace, etc.
F003	Diag Program Memory	Bad flash download, bad flash chip
F004	Diag Video Test	Video memory failed, bad video chip
F005	Diag Interrupts	Bad hardware
F006	Diag A/D Converter	Bad A/D hardware
F007	Diag NM Ram	Corrupt entry on pwr up
F008	Diag Serial Port	Failed pwr up loopback test, bad UART chip
F009	Diag Clock	Bad hardware
F010	Diag Speaker	Speaker not connected on pwr up
F011	Diag Main Power	Mains pwr not detected on pwr up
F012	Diag Battery	Battery voltage on pwr up below 20%

Table 4-4: System Errors		
Code	Description	Possible Cause
I011	L2 SW Watchdog	Bad processor board
I012	L2 Recovered, wLevelTwoErrorCount	Bad processor board
I021	L3 SW Watchdog	Bad processor board
I022	L3 Recovered, wLevelThreeErrorCount	Bad processor board
I031	L4 SW Watchdog	Bad processor board
I032	L4 Recovered, wLevelFourErrorCount	Bad processor board
WD00	Watch dog time exp	Watch dog timer fired
NVP1	Pat Check Pri Fail	NVRAM Primary pattern write failed
NVP2	Pat Check Sec Fail	NVRAM Secondary pattern write failed
NVF0	Pri and Sec NV Files Inv	Primary and secondary NVRAM files invalid
NVF1	Pri NV File Inv	Primary NVRAM file invalid
NVF2	Sec NV File Inv	Secondary NVRAM file invalid
NVC0	Non-Matching CRCS	CRCS for primary and secondary NVRAM did not match
PS01	Charger Error	Check Battery, Connectors

FABIUS GS	DIAGNOSTICS (continued)
------------------	--------------------------------

Table 4-4: System Errors		
Code	Description	Possible Cause
PS02	-2.5V Supply Failure	Bad Processor Board
PS03	+12V Supply Failure	Bad Processor Board
PS04	-5V Supply Failure	Bad Processor Board
PS05	Battery Less Than 18V	Check Battery, Connectors
PS06	+28V Supply Failure	Check AC Power, Fuse, or 28V Supply
PS07	Temp Sensor Failure	Bad Processor Board
PS08	2.5V Supply Failure	Bad Processor Board
PS09	3.3V Supply Failure	Bad Processor Board
PS10	+10V Supply Failure	Bad Processor Board
PS11	+16V Supply Failure	Bad Processor Board

Table 4-5: Service Log Events		
Code	Description	Possible Cause
S006	Service Log Clear	Log cleared by service tech, SW upgrade
SS90	test message	Factory test - no failure
I001	CPU Diag Recovery	CPU recovered from bad initialization

Table 4-6: User Interface Events		
Code	Description	Possible Cause
U001	New Device ID Created	Machine detected a new device ID was needed because of NVRAM corruption or previously did not exist
U002	Option Enabled	A secure option was enabled
U003	Option Disabled	A secure option was disabled
U007	Model Changed to FGS	Model-type change
U008	Model Changed to Tiro	Model-type change
U009	Monitoring Disabled	Monitoring-mode change
U010	Monitoring Enabled	Monitoring-mode change
U012	SOS Recovered	A Secure Option Setting was recovered after a partial NVRAM corruption
U013	FGS SOS Invalid	The FGS Secure Options Setting NVRAM file was found corrupt and no Options were recovered
U014	Tiro SOS Invalid	The Tiro Secure Options Setting NVRAM file was found corrupt and no Options were recovered

Table 4-7: Ventilator Errors

Code	Description	Possible Cause
V001	VENT PEEP NOT CAL	Auto ventilation was attempted without valid PEEP calibration
V002	ZERO POS INVALID	Crossing of light barrier at bottom vent not detected
V037	EX VALVE LEAK	Greater than 15 mL of Tidal Volume during inspiration, and this Vt is greater than 10% of Vt flow during expiration
V042	Motor Voltage Error	Motor voltage has dropped below minimum required for auto ventilation while in Volume or PCV Ventilation mode
V043	MOTOR LIM STOP	Incident of excessive motor current during auto ventilation
V044	MEMBRANE PRES LOW	Membrane vacuum below normal range: possible leak
V045	MEMBRANE PRES HIGH	Membrane vacuum above normal operating range
V049	MOTOR OVER CURRENT	Persistent excessive motor current during auto ventilation: caused ventilator motor shut off
V050	LT Pres Failed>350	Leak in path from vent to hoses to peep valve to bag
V051	LT Pres Rose>250	Leak in path from vent to hoses to peep valve
V052	LT SYS FAIL	Leak in path from vent to hoses to peep valve to bag
V053	LT PC FAIL	Leak in path from vent to hoses to peep valve
V060	Comp Unexp State	Compliance test entered an unexpected test state
V061	Comp Bag Pres Too High	Compliance test start pressure too high
V062	Comp Cant Fully Pres	Compliance test could not attain complete pressurization
V063	Comp Cant Hold Pres	Compliance test could not maintain plat. pressure
V064	COMP Cant DePres	Pressure not dropping during compliance test
V065	COMP Inv Pres	Pressure changing in the wrong direction during compliance test
V066	COMP Inv Pres	Pressure changing in the wrong direction during compliance test
V067	COMP Sys < VentHose	Irregular compliance test results
V069	Comp Unexpected Error	Compliance test entered an unexpected error state
V070	COMP Sys Fail in Range	Unusable compliance value
V071	COMP Sys Fail out of Range	Unusable compliance value
V072	COMP VH Fail in Range	Unusable vent hose compliance value
V073	COMP VH Fail out of Range	Unusable vent hose compliance value

4.3.2 Real Time Values

When Real Time Values is selected, the typical screen shown in [Figure 4-7](#) appears.

Refer to [Table 4-8](#): for Real Time Value item descriptions and acceptable range data.

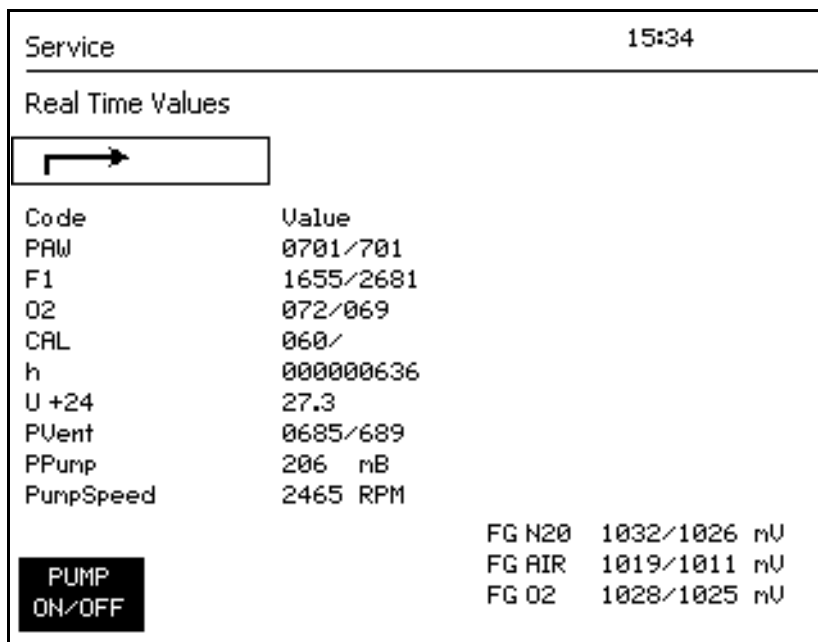

Figure 4-7. Real Time Values Screen Appearance with PCB 4116632

Refer to [Table 4-9](#): for Battery/Charger Status error message list and [Table 4-10](#): for PSC (Power Supply Controller) error message list as shown on the following screen.

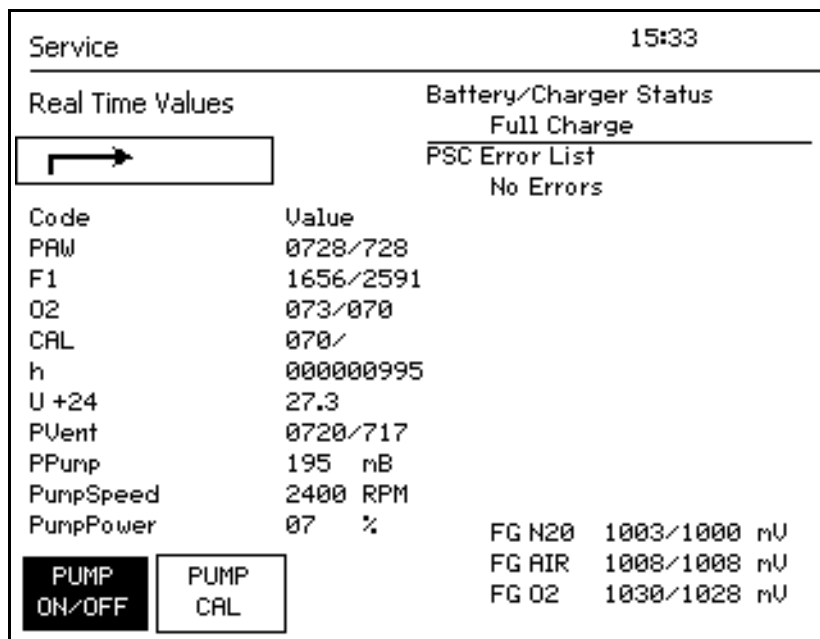

Figure 4-8. Real Time Values Screen Appearance with PCB 4118079

Press the knob to return to the Service Log category screen.

FABIUS GS	DIAGNOSTICS (continued)
------------------	--------------------------------

Table 4-8: Real Time Values Screen Key and Acceptable Range Data

Label	Description	Acceptable Range
Paw	(AD) Pressure Sensor Calib. value	Max 825 (ambient) Min 650 (ambient)
F1	(AD) Flow Sensor Calib. value	0 - 4095
O2	O2 Sensor Channel (in mV) Channel 1 + 2	OFFSET Min 39 - 9,64 mV (21%) OFFSET Max 541 132,00 mV(100%)
CAL	Calibration State of O2 Sensor and Calibration value	Average stored value between OFFSET Min and OFFSET Max
h	Operating Hours (full hours)	N/A
U+24	Supply voltage in V	Max - 29 Volts Min - 21 Volts
Pvent	Ventilator Pressure	Max 825 (ambient) Min 650 (ambient)
PP	Pump Vacuum Pressure	0- 120 mB (Pump OFF) 120 - 270 mB (Pump ON)
Pump Speed	Pump Motor Speed in RPM	No MIN/MAX, typically 2400 to 2800 RPM when running
Pump Power	Percentage of full power in use (only on 4118079 PCB)	0 to 100%, typically 6 to 15% running

DIAGNOSTICS (continued)	FABIUS GS
--------------------------------	------------------

Table 4-9: Battery/Charger Status Error Message List

Message	Description	Condition
Charger OFF	The PSC has detected a +28V supply failure or a Charge error.	Refer to Table 4-10 : for additional conditions.
Slow Charging	The charger is trickle charging the battery until voltage rises to 24V.	Normal after the machine has had no AC power for an extended period of time.
Bulk Charging	The charger delivers the maximum charging current to the battery.	Normal after the machine has run on battery.
Full Charge	The charger keeps the battery voltage at a consistent charging voltage, which is above the rated voltage, for 3 hours.	Normal after the machine has run on battery and been recharged.
Holding Full Charge	The charger is maintaining full charge on the battery.	Normal when battery is in good condition and has been charged correctly.
No PSC Data	The PSC is not communicating.	If condition persists, check service log, possible replace PSC.

Table 4-10: PSC (Power Supply Controller) Error Message List

Message	Description	Condition
Charger Error	Charging process has timed out	Check battery, connectors
-2.5V supply failure	<-2.5 or >-2.25 Volts	PCB problem
+12V supply failure	<10.8 or >13.2 Volts	PCB problem
+5V supply failure	<4.5 or >5.5 Volts	PCB problem
Battery less than 18V	<18 Volts	Check battery, connectors
+28V supply failure	<25.2 or >30.8 Volts	Check AC power, fuse or 28V supply
Temp sensor failure	<.5 or >1.5 Volts	PCB problem
2.5V supply failure	<2.25 or >2.75 Volts	PCB problem
3.3V supply failure	<3.0 or >3.6 Volts	PCB problem
+10V supply failure	<9.0 or >11.0 Volts	PCB problem
+16V supply failure	<14.4 or >17.6 Volts	PCB problem

4.4 Preventive Maintenance

When the Preventive Maintenance category is selected, the screen shown in [Figure 4-9](#) will appear.

Turn the rotary knob to select Activate, then press the knob to confirm. The next preventive maintenance due date can then be set using the screen described on the next page.

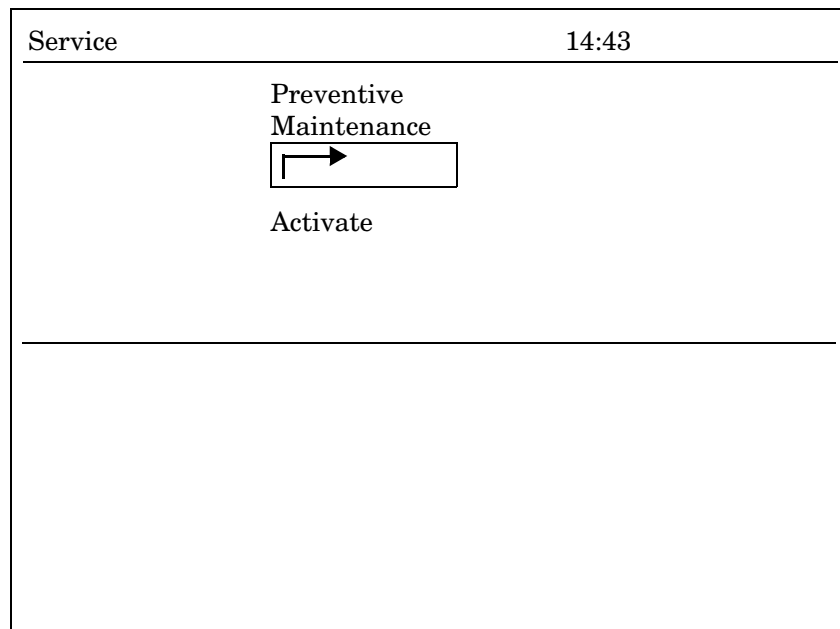

Figure 4-9. Preventive Maintenance Category Selected

4.4.1 Activate Preventive Maintenance Date

With Activate selected, the screen will appear as shown in [Figure 4-10](#). Turn the rotary knob to position the box under Mth and press the knob to highlight the box. Turn the knob to select the next month preventive maintenance is due, and press the knob to enter the month.

With the box under Day, press the knob to highlight the box. Turn the knob to select the desired day, then press the knob to enter the day.

With the box under Year, press the knob to highlight the box. Turn the knob to select the year, and press the knob to enter the year.

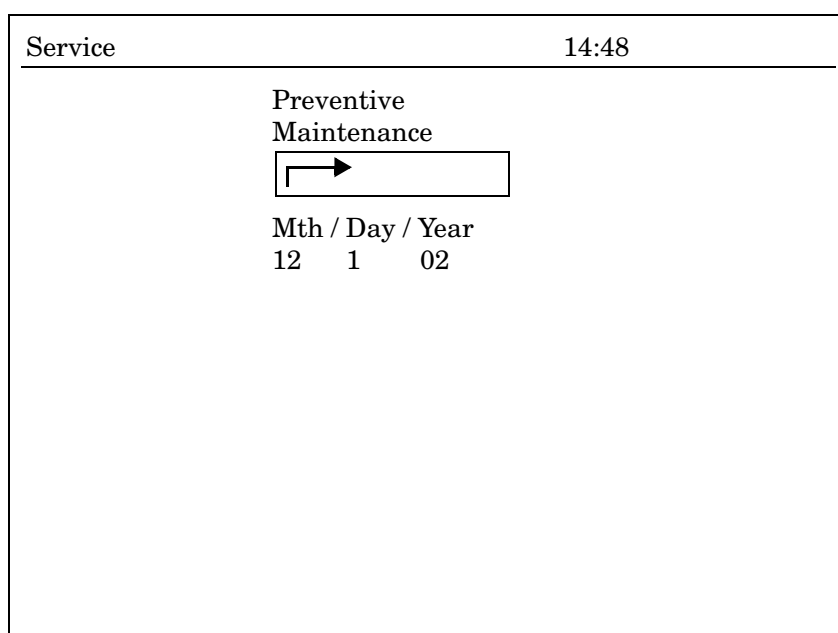



Figure 4-10. PMS Due Date Screen

To return to the main service screen, scroll to the  and press the knob.

4.5 General

When the General category is selected, the screen shown in [Figure 4-11](#). will appear.

Turn the rotary knob to scroll down to select the desired function, then press the knob to confirm. The general screens are described in the following pages.

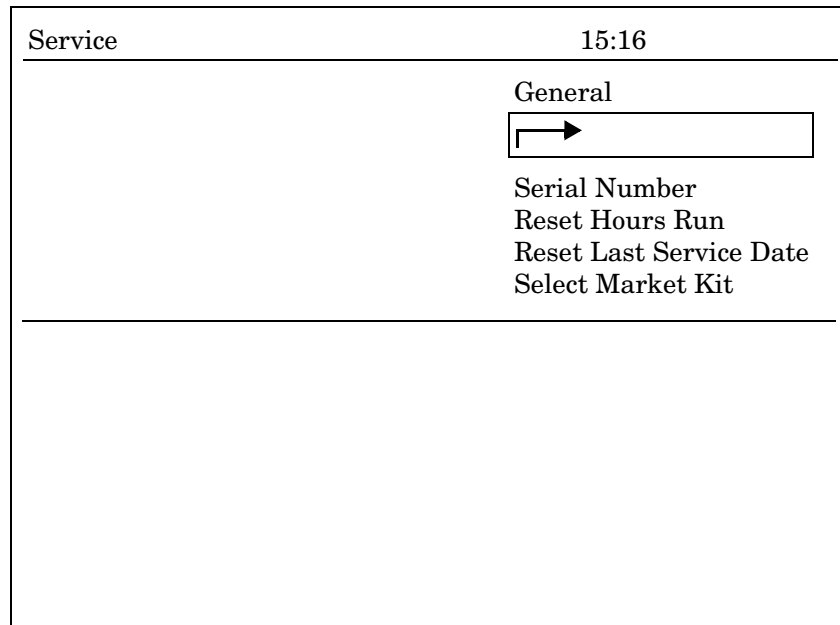

Figure 4-11. General Category Selected

4.5.1 Serial Number

When Serial Number is selected, the screen will appear as shown in [Figure 4-12](#). Turn the rotary knob to position the box on the first digit of the serial number, then press the knob to highlight the number. Turn the knob to display the desired number, then press the knob to enter the number. The box will then step to the next digit. Press the knob to highlight the number. Turn the knob to select the next digit of the serial number, and press the knob to enter the digit. Continue entering each digit of the serial number in the same manner. The serial number entered shall be the same as on the rear of the machine.

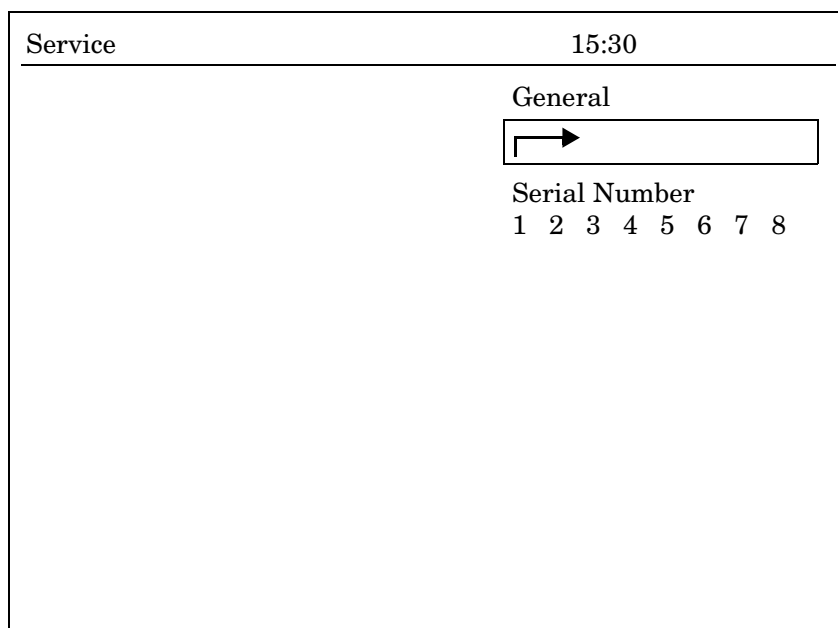
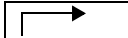

Figure 4-12. Serial Number Screen

To return to the General category screen, scroll to the  and press the knob.

4.5.2 Reset Hours Run

When Reset Hours Run is selected, the screen will appear as shown in [Figure 4-13](#). Turn the rotary knob to select Reset Hours Run, and press the knob to highlight the selection. Then turn the knob to select Yes or No. Selecting Yes will reset the hours run to zero. Press the knob to enter the selection.

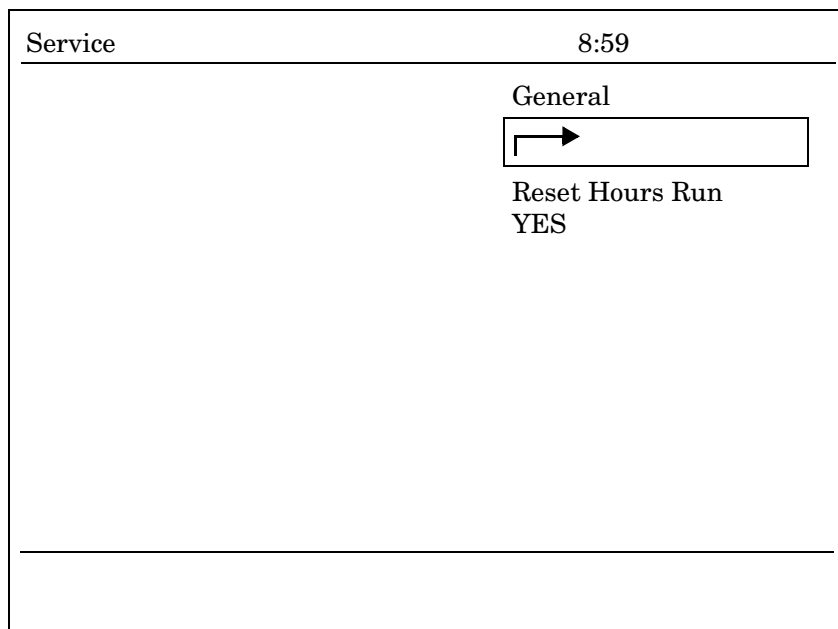



Figure 4-13. Reset Hours Run Screen

To return to the General category screen, scroll to the  and press the knob.

4.5.3 Reset Last Service Date

When Reset Last Service Date is selected, the screen will appear as shown in [Figure 4-14](#). Turn the rotary knob to select Reset Last Service Date, and press the knob to highlight the selection. Then turn the knob to select Yes or No. Selecting Yes will reset the last service date to the current date. Press the knob to enter the selection.

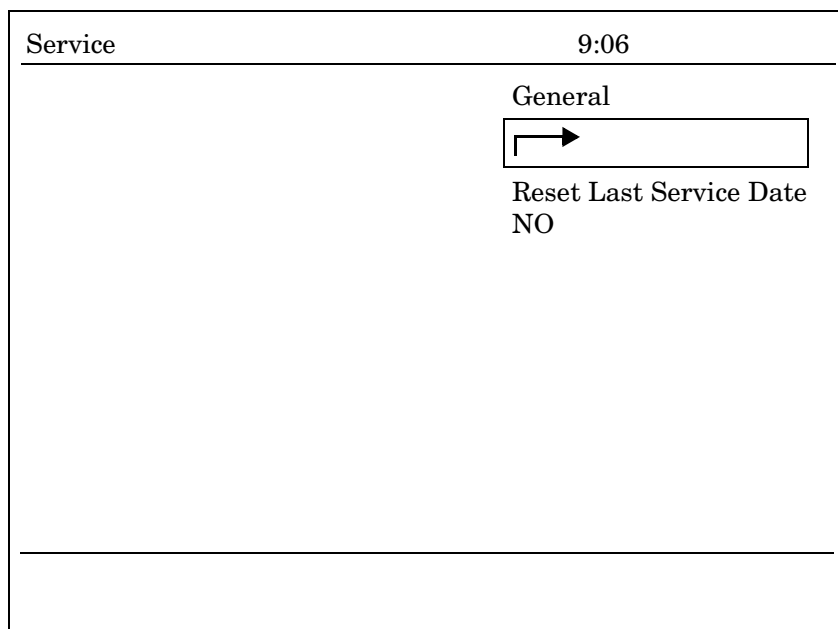



Figure 4-14. Reset Last Service Date Screen

To return to the General category screen, scroll to the  and press the knob.

4.5.4 Select Market Kit

When Select Market Kit is selected, the screen will appear as shown in [Figure 4-15](#). or [Figure 4-16](#). Turn the rotary knob to scroll to Select Market Kit, and press the knob to highlight the selection. Then turn the knob to select U.S. or Non-U.S.

When U.S. is selected, the only language supported is English and the pressure unit of measure is set to cmH2O. The options to choose a different language or pressure unit are eliminated while in the “U.S.” mode.

Selecting Non-U.S. mode enables the option to select language and pressure units of measure from the standby menu.

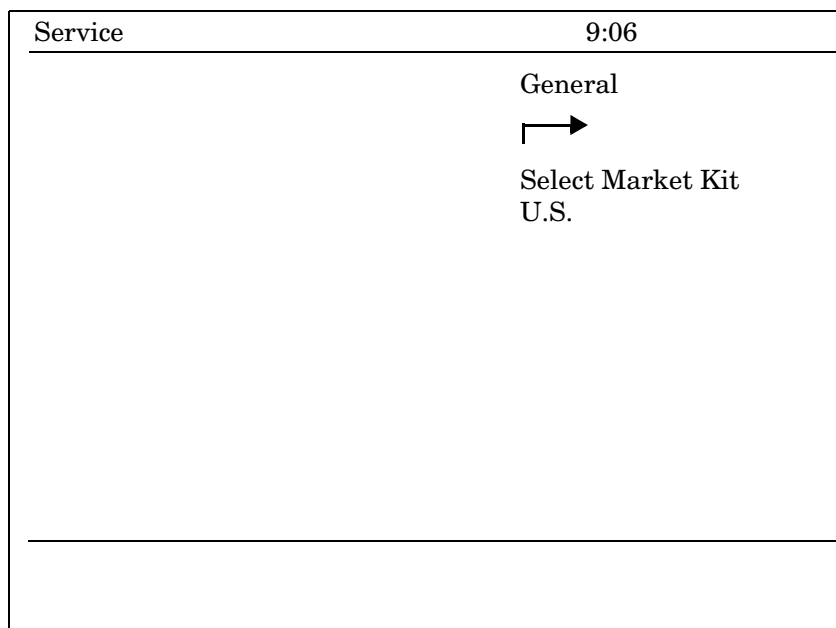

Figure 4-15. Select Market Kit Screen (US)

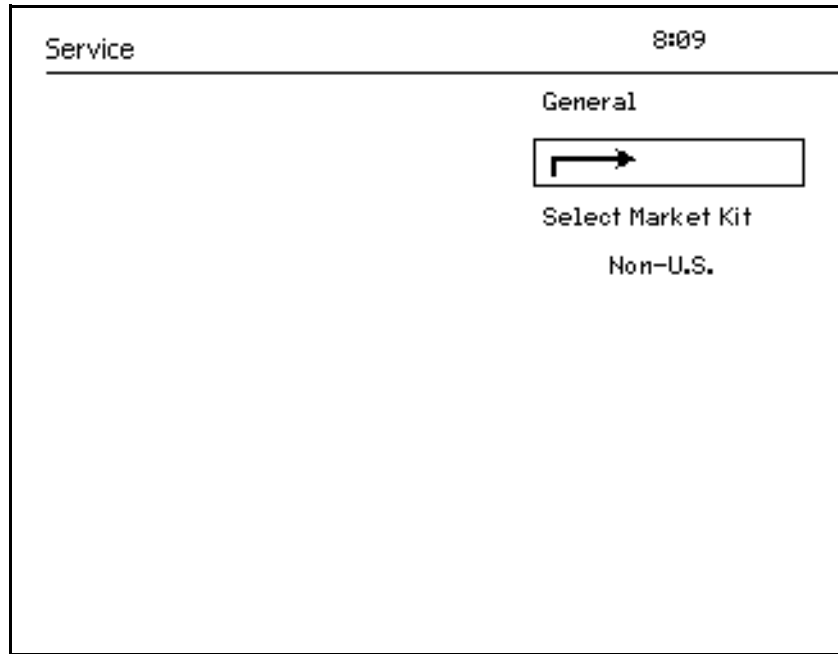



Figure 4-16. Select Market Kit Screen (Non-US)

To return to the General category screen, scroll to the  and press the knob.

4.6 Calibration

When the Calibration category is selected, the screen shown in [Figure 4-17](#). will appear.

Turn the rotary knob to scroll down to select the desired function, then press the knob to confirm. The calibration screens are described in the following pages.

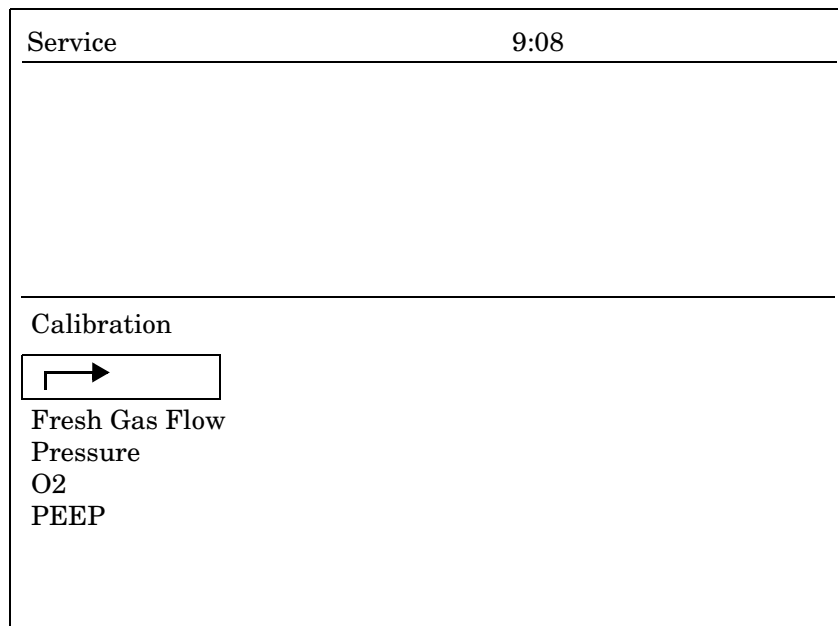

Figure 4-17. Calibration Category Selected

4.6.1 Fresh Gas Flow Calibration

When Fresh Gas Flow is selected, the screen shown in [Figure 4-18](#) appears.

Follow the on-screen instructions to perform the calibration. The Store Zero and Exit keys are located just below their legends at the bottom of the screen.

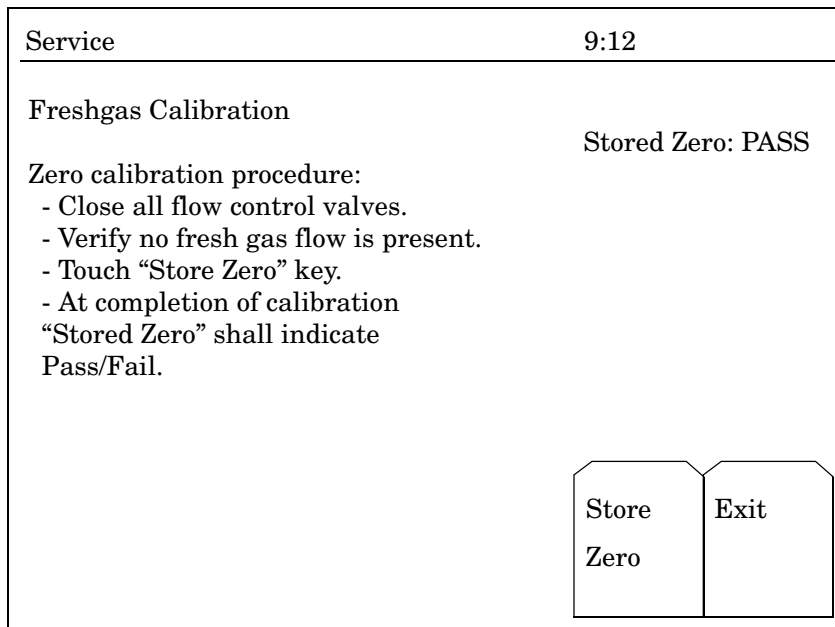



Figure 4-18. Fresh Gas Flow Calibration Screen

Press the Exit key to return to the Calibration category screen, or the  key to return to the Standby screen.

4.6.2 Pressure Calibration

When Pressure is selected, the screen shown in [Figure 4-19](#) appears.

Follow the on-screen instructions to perform the calibration. The Store Zero and Exit keys are located just below their legends at the bottom of the screen.

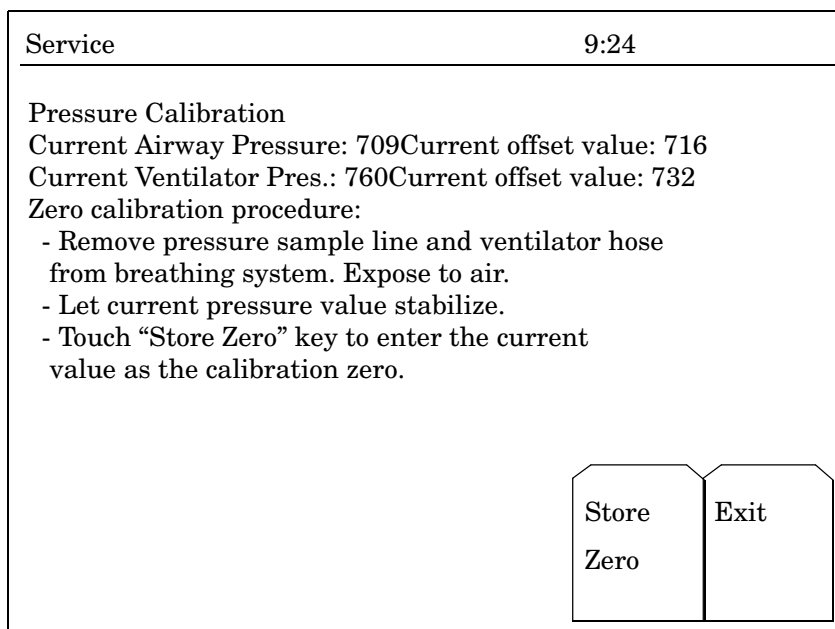



Figure 4-19. Pressure Calibration Screen

Press the Exit key to return to the Calibration category screen, or the  key to return to the Standby screen.

4.6.3 O2 Zero Calibration

When O2 is selected, the screen shown in [Figure 4-20](#) appears.

Follow the on-screen instructions to perform the calibration. The Store Zero and Exit keys are located just below their legends at the bottom of the screen.

If the calibration process fails, a “value not stored” message is displayed in place of the Stored zero cell A or cell B values.

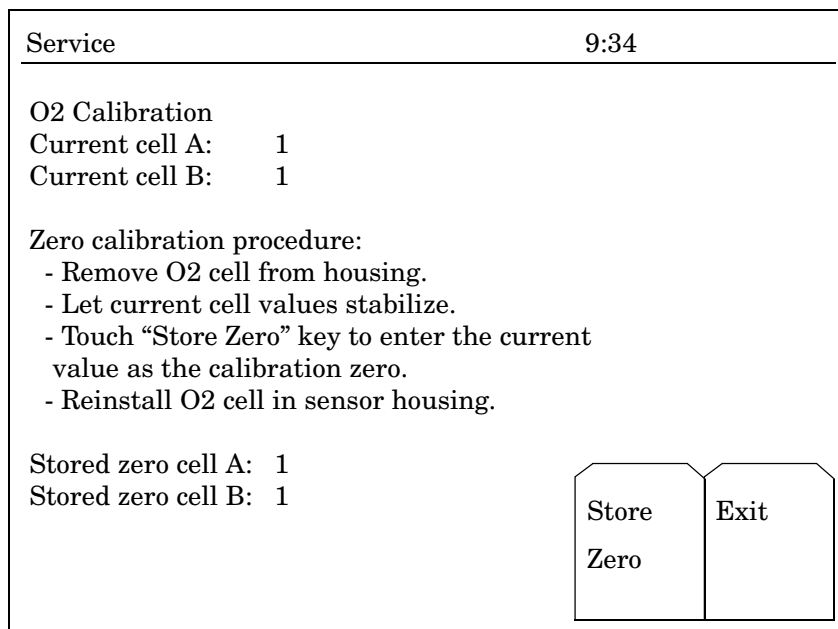



Figure 4-20. O2 Zero Calibration Screen

Press the Exit key to return to the Calibration category screen, or the  key to return to the Standby screen.

4.6.4 PEEP Valve Calibration

When PEEP is selected, the screen shown in Figure 4-21. appears.

NOTE: Before performing the PEEP valve calibration, a valid pressure calibration must be performed. Otherwise, an 'Inv pres. cal' message will appear.

Follow the on-screen instructions to perform the calibration. During calibration, an "In Progress" message is displayed. When the procedure is complete a PASS or FAIL message is displayed. The Calibrate and Exit keys are located just below their legends at the bottom of the screen.

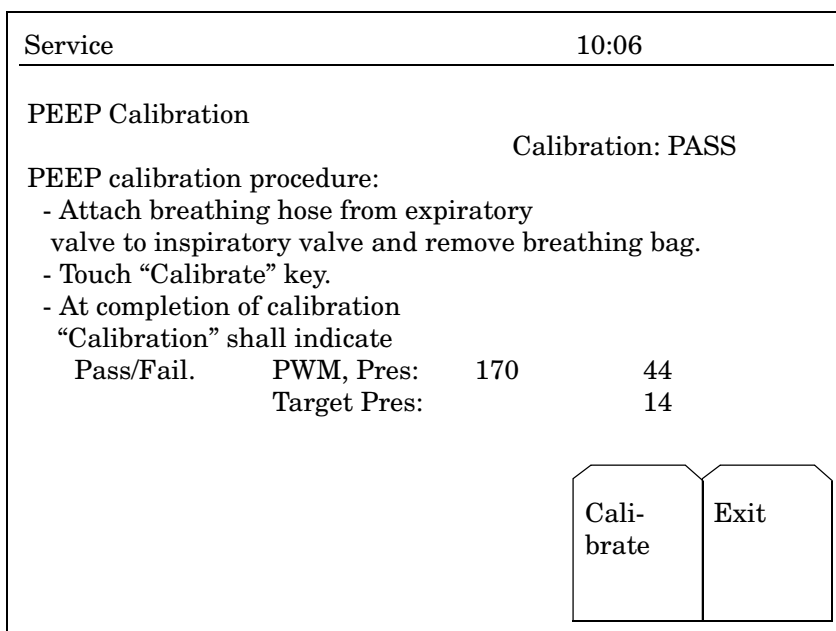



Figure 4-21. PEEP Calibration Screen

Press the Exit key to return to the Calibration category screen, or the  key to return to the Standby screen.

4.7 Configure

When the Configure category is selected, the screen shown in [Figure 4-22](#) will appear.

Turn the rotary knob to scroll down to select the desired function, then press the knob to confirm. The flowmeter screens are described in the following pages.

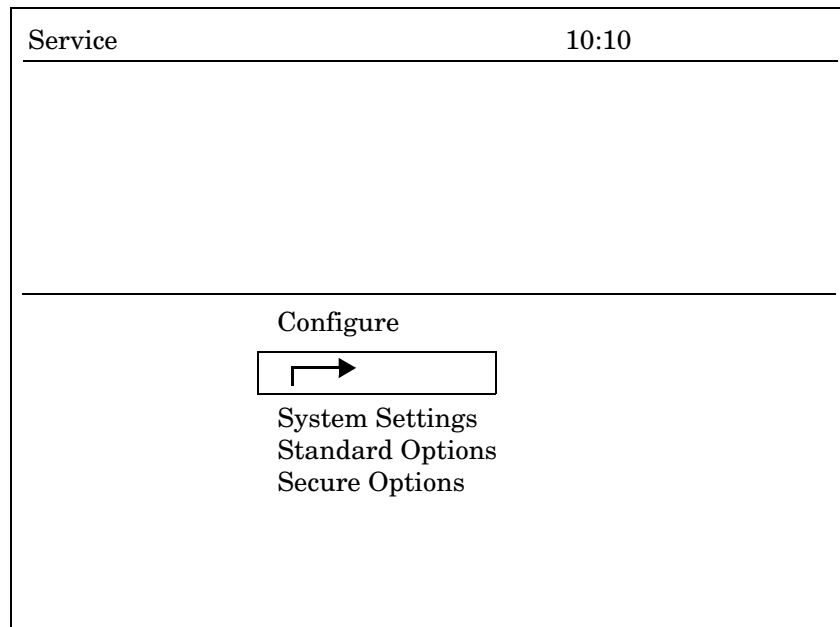

Figure 4-22. Configure Category Selected

4.7.1 System Settings (US and Non-US)

When the System Settings category is selected, the screen shown in [Figure 4-23](#) or [4.7.1.1](#) will appear.

Turn the rotary knob to scroll down to select the desired market kit, then press the knob to confirm.

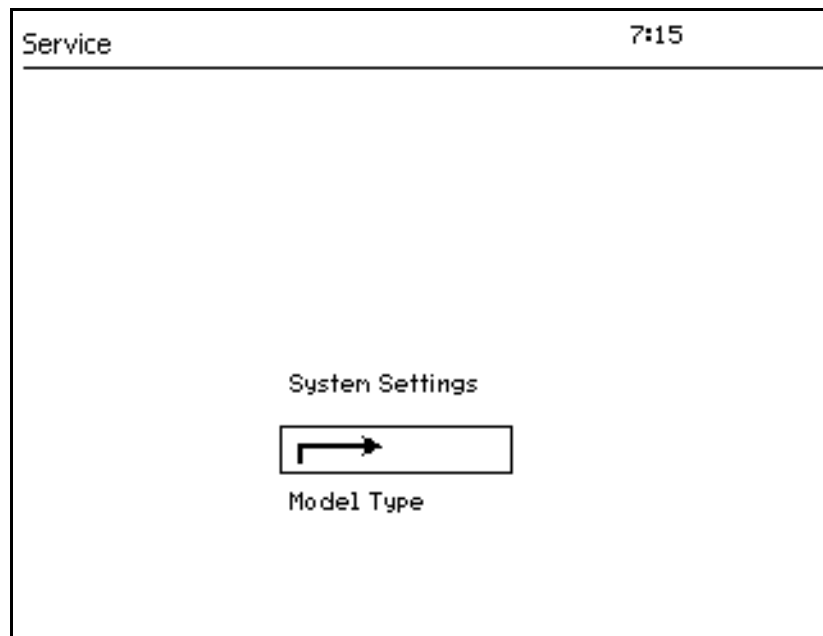

Figure 4-23. System Settings Screen

4.7.1.1 Model Type

When the Model Type category is selected, the screen shown in [Figure 4-24](#) will appear.

Turn the rotary knob to scroll down to select the model type 'Fabius GS', then press the knob to confirm.

NOTE: Machines from the factory are configured with the appropriate model type. Other than performing a software download or PCB replacement, the model type should not be changed. Changing the model type will disable some ventilator options previously configured and will require reconfiguration.

To reconfigure the unit, contact DrägerService - Technical Support: Phone: 1-800-4-Dräger, Phone: 215-721-5402, or e-mail to techsupport@draegermed.com and provide the following information to receive the necessary release codes:

- Machine Type (Fabius GS or Fabius Tiro)
- Feature Description and Part Number
- Machine Serial Number
- Device ID Number

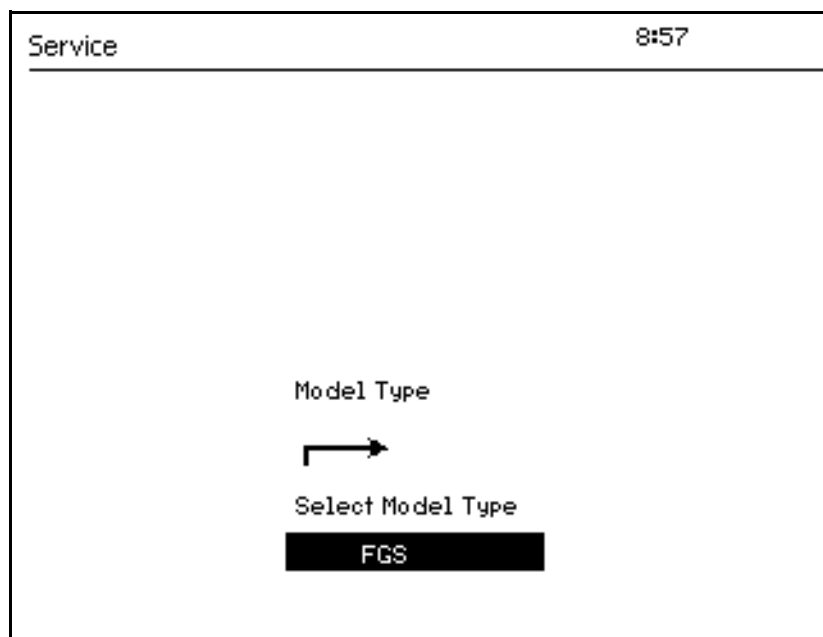

Figure 4-24. Typical Model Type Screen

4.7.2 Standard Options

When the Standard Options category is selected, the screen shown in [Figure 4-25](#) will appear.

Turn the rotary knob to scroll down to select the desired function, then press the knob to confirm.

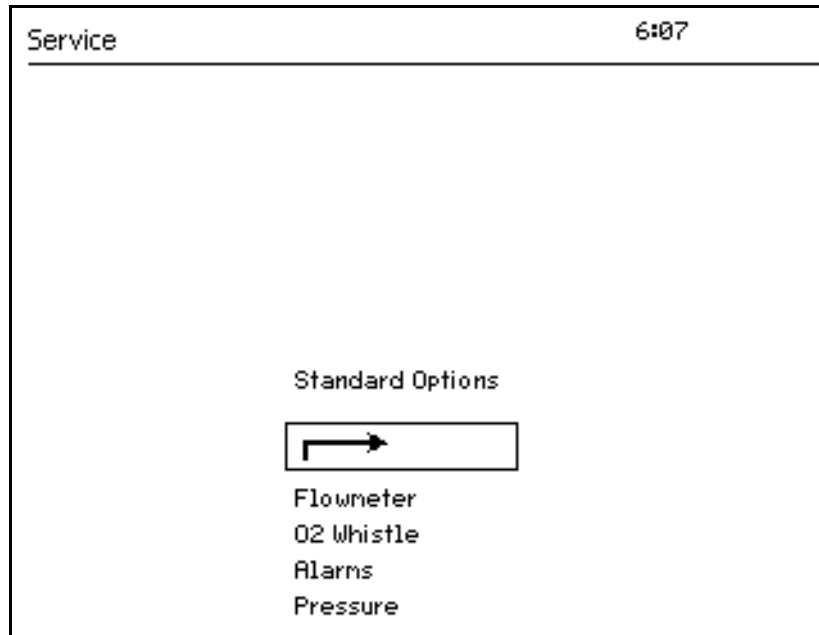
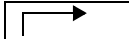

Figure 4-25. Standard Options Screen

To return to the Configure screen, scroll to the  and press the knob.

4.7.2.1 Flowmeter

When Flowmeter is selected, the screen shown in one of the following illustrations will appear. Turn the knob to scroll down to the desired selection, and press the knob to enter that function.

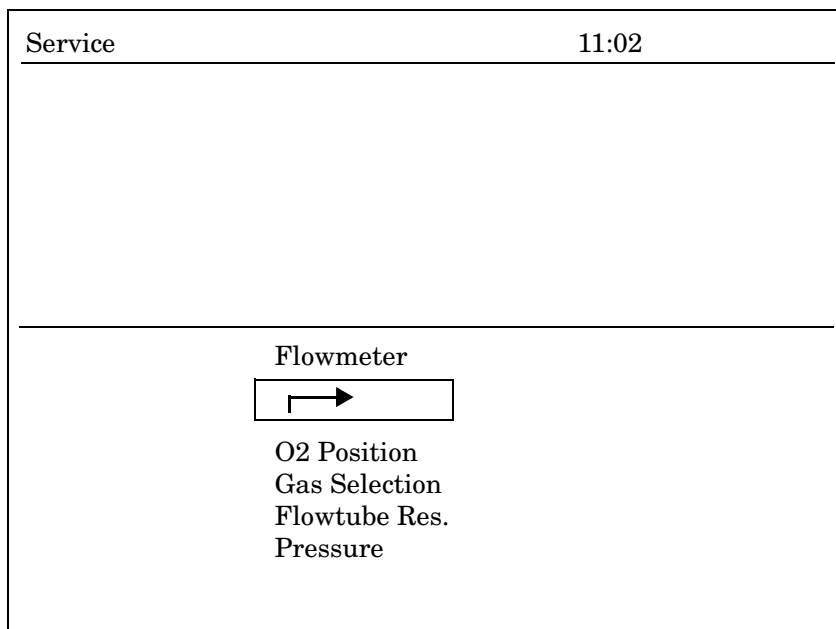
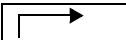

Figure 4-26. Flowmeter Selection Screen

To return to the Standard Options category screen, scroll to the  and press the knob.

4.7.2.1.1 O2 Position (Virtual Flowtubes)

When O2 Position for virtual flowtubes is selected, the screen will appear as shown in Figure 4-27. Turn the rotary knob to select O2 Position, and press the knob to highlight the choices. Turn the knob to select either LEFT or RIGHT, then press the knob to enter that selection.

By entering the desired position (left or right), the virtual O2 flow position is relative to the air virtual flow tube. The air virtual flow tube is always located in the center position.

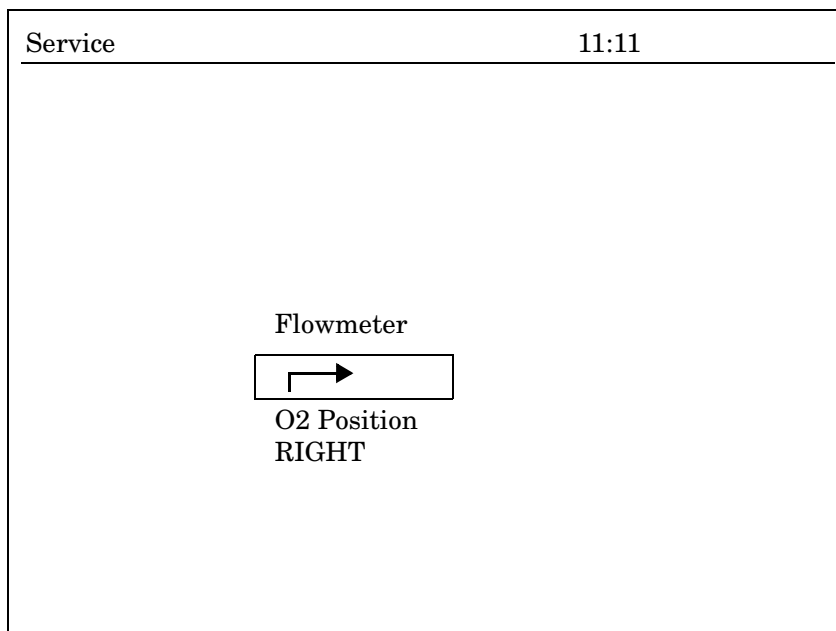



Figure 4-27. O2 Flowmeter Position Screen (Virtual Flowtubes)

To return to the Flowmeter selection screen, scroll to the  and press the knob.

4.7.2.1.2 Gas Selection

When Gas Selection is chosen, the screen will appear as shown in [Figure 4-28](#). Turn the rotary knob to choose Gas Selection, and press the knob to highlight the choices. Turn the rotary knob to select either 2 or 3, then press the knob to enter that selection.

The gas selection number 2 or 3 shall match the total gas options pneumatically configured on the unit.

Otherwise a 'ERR' will occur on the fresh gas digital display, where applicable.

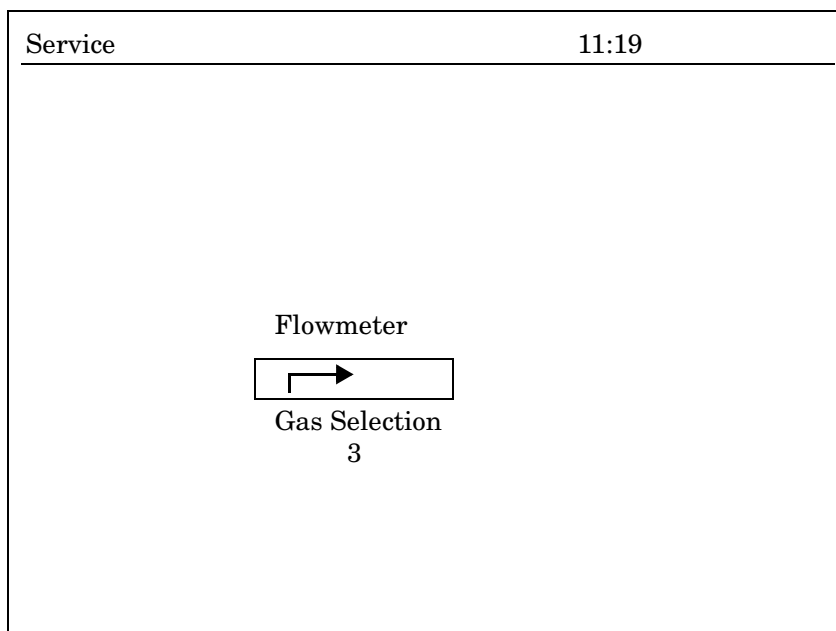
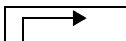

Figure 4-28. Gas Selection Screen

To return to the Flowmeter selection screen, scroll to the  and press the knob.

4.7.2.1.3 Flowtube Resolution

When Flowtube Resolution is chosen, the screen will appear as shown in Figure 4-29. Turn the rotary knob to choose Flowtube Resolution, and press the knob to highlight the choices. Turn the rotary knob to select either Change State or High Res, then press the knob to enter that selection.

High resolution provides a 3 digit resolution to the 3 fresh gas digital flow displays - Low resolution provides 2 digit resolution.

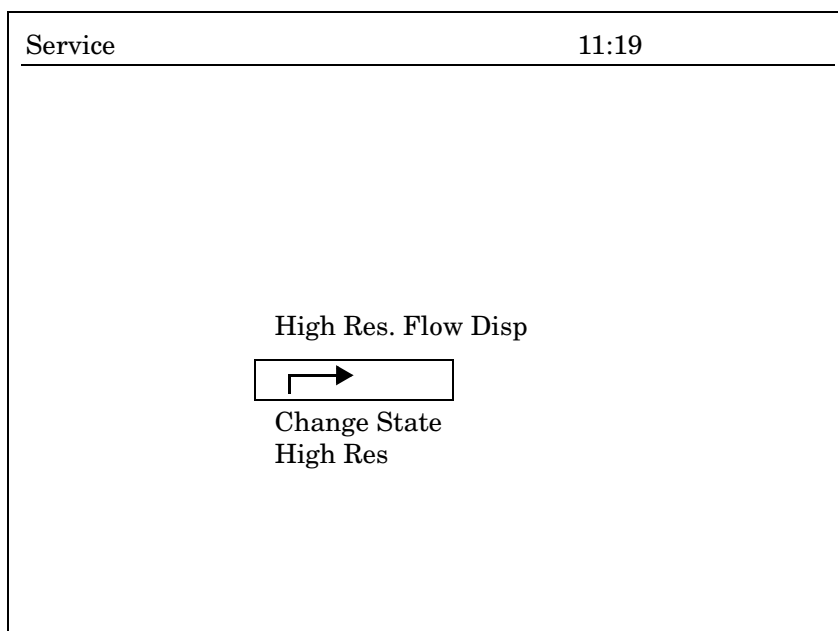



Figure 4-29. Flowtube Resolution Screen

To return to the Flowmeter selection screen, scroll to the  and press the knob.

4.7.2.2 O2 Whistle

When O2 Whistle is chosen, the screen will appear as shown in [Figure 4-30](#). Turn the rotary knob to select Change State, and press the knob to highlight the choices. Then turn the rotary knob to select either ENABLE or DISABLE, and press the knob to enter that selection.

By selecting Enable, the unit provides an electronic whistle which activates when Lo O2 supply is detected.

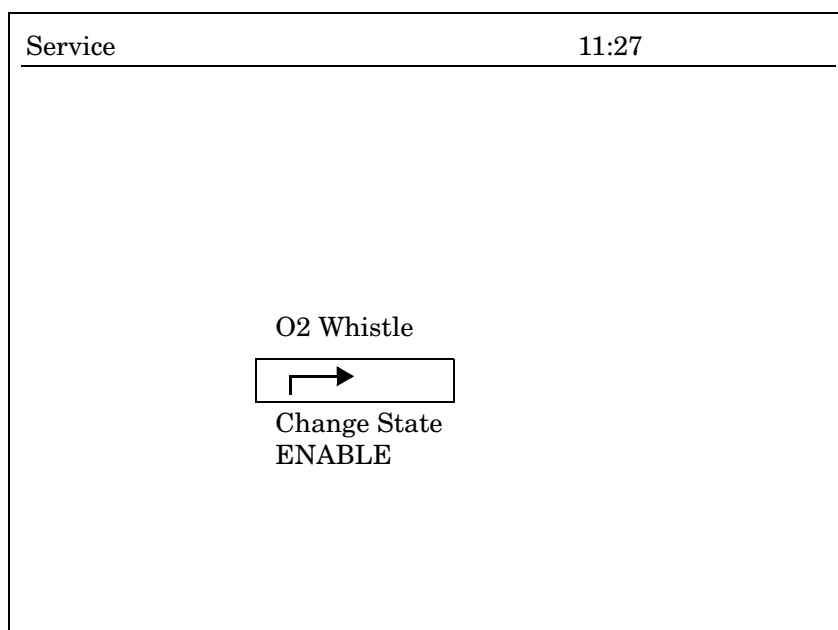
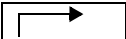

Figure 4-30. O2 Whistle Selection

To return to the Configure category screen, scroll to the  and press the knob.

4.7.2.3 Alarms

When Alarms is selected, the screen shown in [Figure 4-31](#) will appear. Turn the knob to scroll down to the desired selection, and press the knob to enter that function.

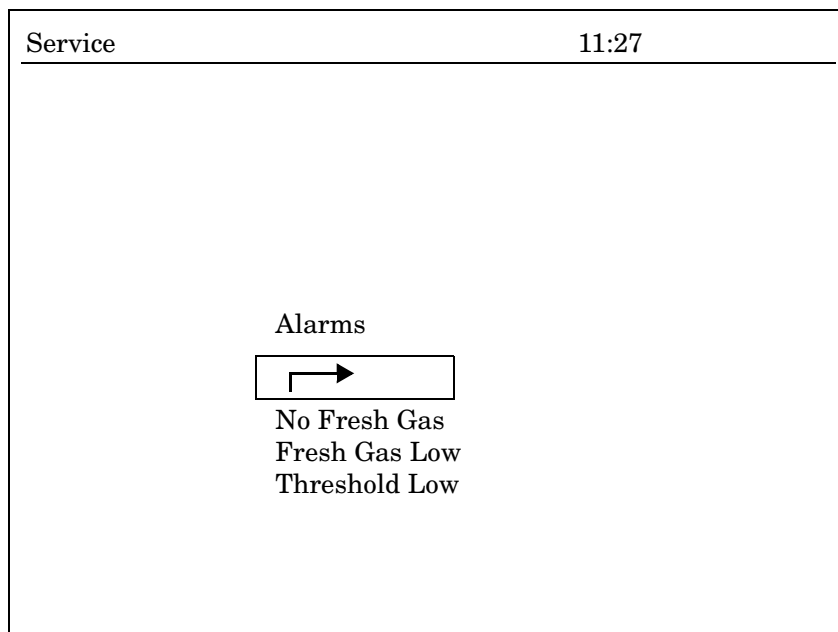



Figure 4-31. Alarms Selection Screen

To return to the Configure category screen, scroll to the  and press the knob.

4.7.2.3.1 No Fresh Gas

When No Fresh Gas is chosen, the screen will appear as shown in [Figure 4-32](#). Turn the rotary knob to select Change State, and press the knob to highlight the choices. Then turn the rotary knob to select either ENABLE or DISABLE, and press the knob to enter that selection.

Enabling No Fresh Gas provides a message to the operator when the fresh gas sensor detects no flow while in an active ventilator mode.

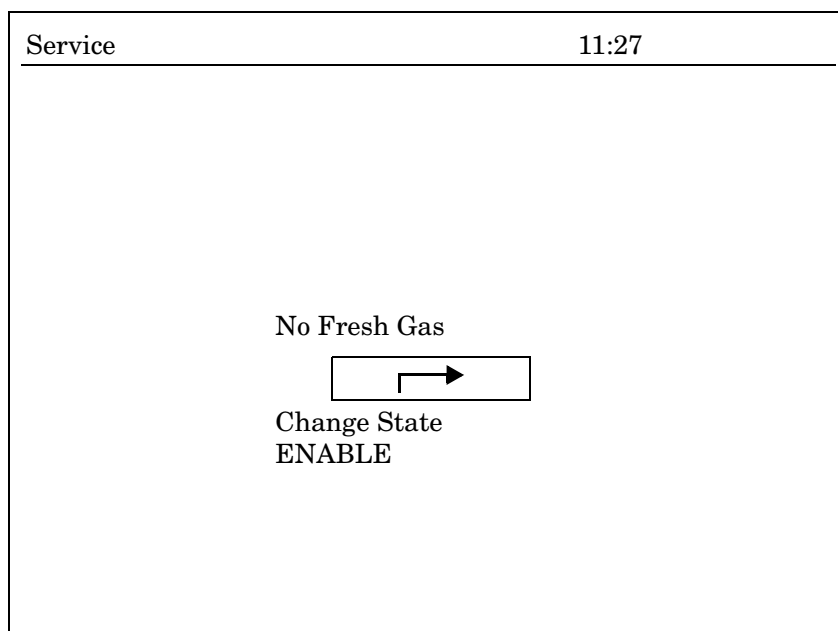



Figure 4-32. No Fresh Gas Selection Screen

To return to the Alarms category screen, scroll to the  and press the knob.

4.7.2.3.2 Fresh Gas Low Alarm

When Fresh Gas Alarm is chosen, the screen will appear as shown in [Figure 4-33](#). Turn the rotary knob to select Change State, and press the knob to highlight the choices. Then turn the rotary knob to select either ENABLE or DISABLE, and press the knob to enter that selection.

An Enabled Fresh Gas Lo alarm provides a message to the operator when the available fresh gas is set such that -8 mbar auxiliary air valve opens to maintain the present Vt delivery.

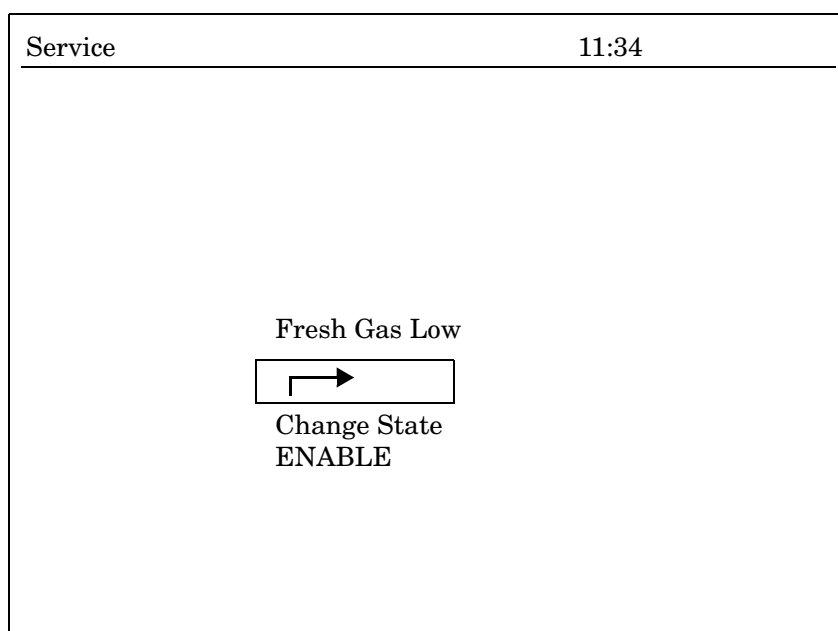



Figure 4-33. Fresh Gas Alarm Selection Screen

To return to the Alarms category screen, scroll to the  and press the knob.

4.7.2.3.3 Threshold Low Alarm

When Threshold Low Alarm is chosen, the screen will appear as shown in [Figure 4-34](#). Turn the rotary knob to select Change State, and press the knob to highlight the choices. Then turn the rotary knob to select either ENABLE or DISABLE, and press the knob to enter that selection.

A Threshold Low alarm that is enabled provides a corresponding alarm when the current threshold is set too low relative to the peak pressure.

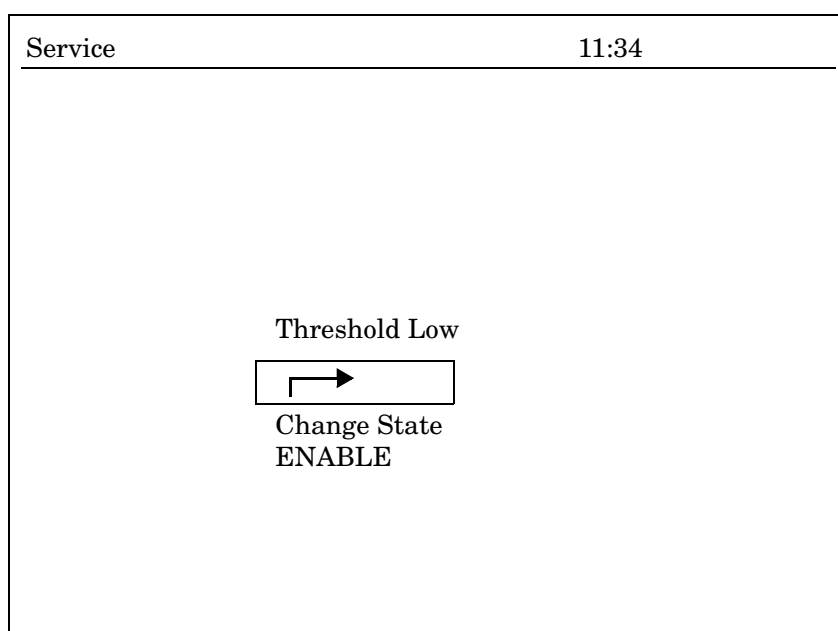



Figure 4-34. Threshold Low Alarm Selection Screen

To return to the Alarms category screen, scroll to the  and press the knob.

4.7.2.4 Pressure

When Flowmeter is selected, the screen shown in [Figure 4-35](#) will appear. Turn the knob to scroll down to the desired selection, and press the knob to enter that function.

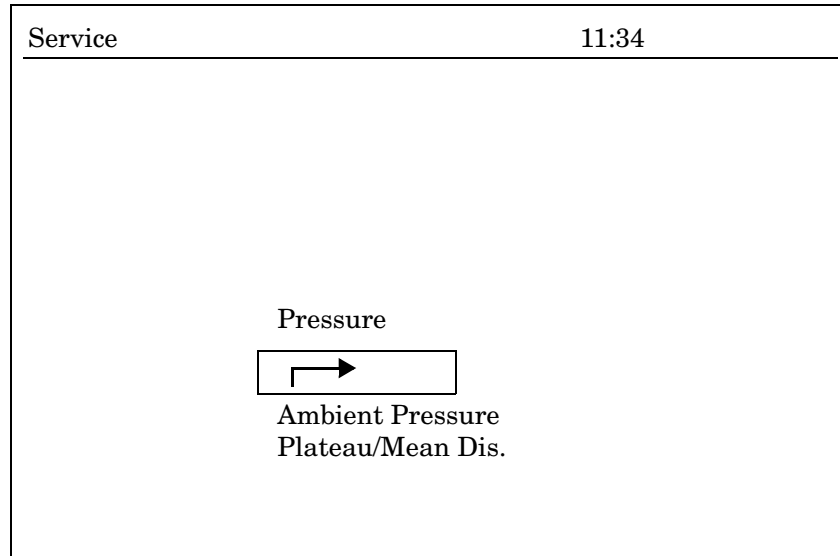



Figure 4-35. Pressure Screen

To return to the Configure category screen, scroll to the  and press the knob.

4.7.2.4.1 Ambient Pressure

When Ambient Pressure is chosen, the screen will appear as shown in Figure 4-36. Turn the rotary knob to select Adjust, and press the knob. Then turn the knob to set the correct ambient pressure in mbar for the location the unit will reside, and press the knob to enter the value.

Using the table found in Section 7.0, set the ambient pressure (mbar) in accordance with the local elevation. Refer to step 7.7.9 for additional information.

NOTE: It is imperative the ambient pressure setting is properly set. Otherwise, erroneous Vt settings could result.

Changes in barometric pressure resulting from local weather conditions have minimal to no affect on Vt readings. Therefore, it is not necessary to change the ambient pressure setting with changing local weather conditions.

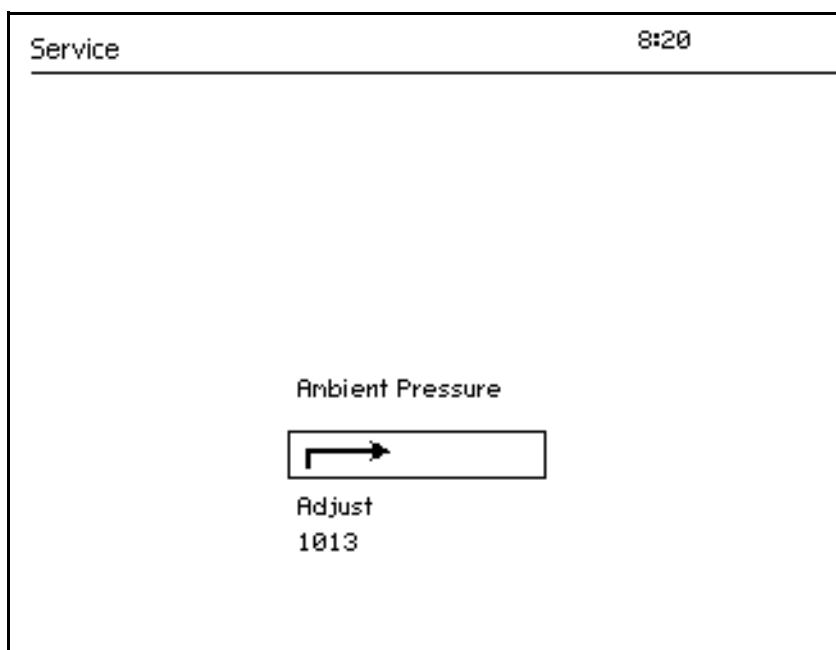



Figure 4-36. Ambient Pressure Screen

To return to the Pressure category screen, scroll to the  and press the knob.

4.7.2.4.2 Plateau-Mean Display Screen

The breathing pressure monitor window can display Mean airway pressure or Plateau airway pressure.

When Plateau is chosen, the screen will appear as shown in Figure 4-37. Turn the rotary knob to make the desired selection, and press the knob.

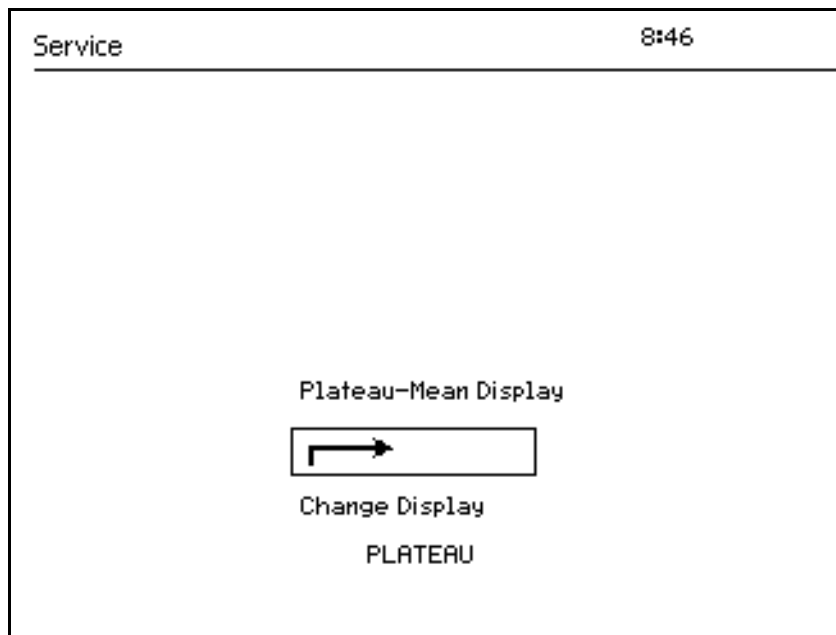
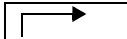

Figure 4-37. Plateau-Mean Display Screen

To return to the Pressure category screen, scroll to the  and press the knob.

4.7.3 Secure Options

When the Secure Options category is selected, the screen shown in [Figure 4-38](#). will appear.

Turn the rotary knob to scroll down to select the desired function, then press the knob to confirm.

The Secure Options screen provides the Draeger Service or Authorized Service Organization representative to enable or disable certain ventilator options.

Inquiries regarding Secure Options or Ventilator Options shall be directed to DrägerService - Technical Support: Phone 1-800-4-Drager, Phone: 215-721-5402, or e-mail to techsupport@draegermed.com.

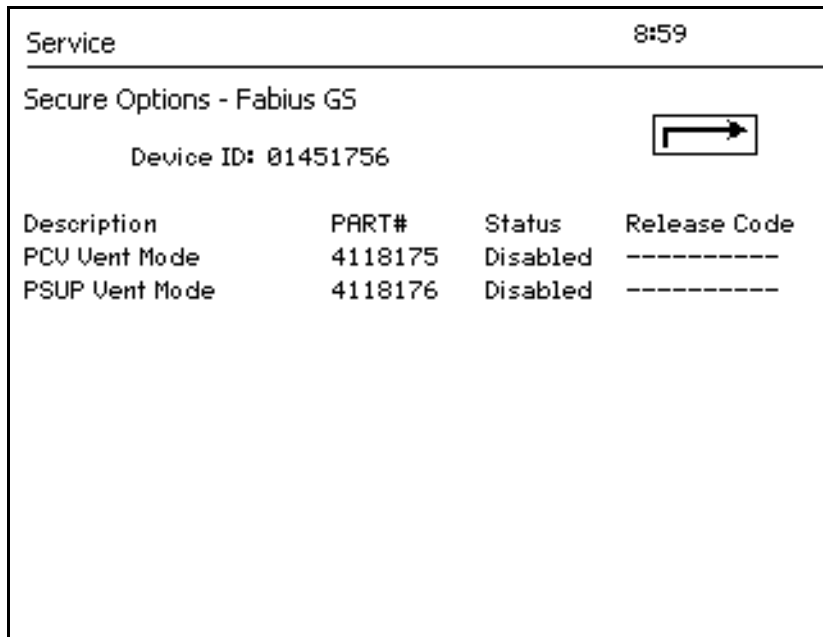

Figure 4-38. Secure Options - Enabled

4.8 Serial Port

When the Serial Port category is selected, the screen shown in [Figure 4-39](#). will appear.

Turn the rotary knob to select Parameters, then press the knob to confirm. The serial port communication parameters can then be set using the screen described on the next page.

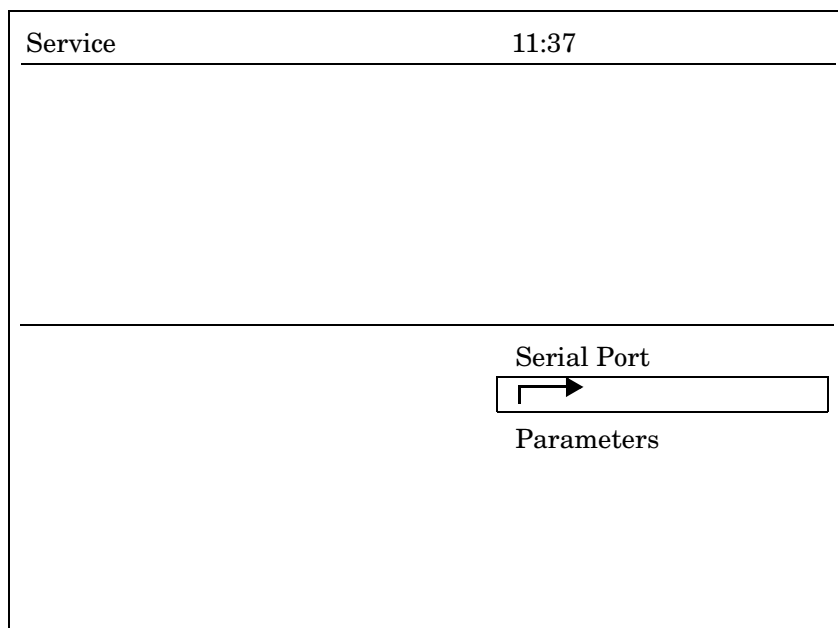

Figure 4-39. Serial Port Category Selected

4.8.1 Serial Port Parameters

With Parameters selected, the screen will appear as shown in [Figure 4-40](#). Turn the rotary knob to select the parameter you want to set, and press the knob to highlight that parameter. Then turn the knob to select the desired value for that parameter. Press the knob again to enter the value. Scroll to the next parameter and repeat the process to enter a value. The table below lists the values available for each parameter, along with the factory default values.

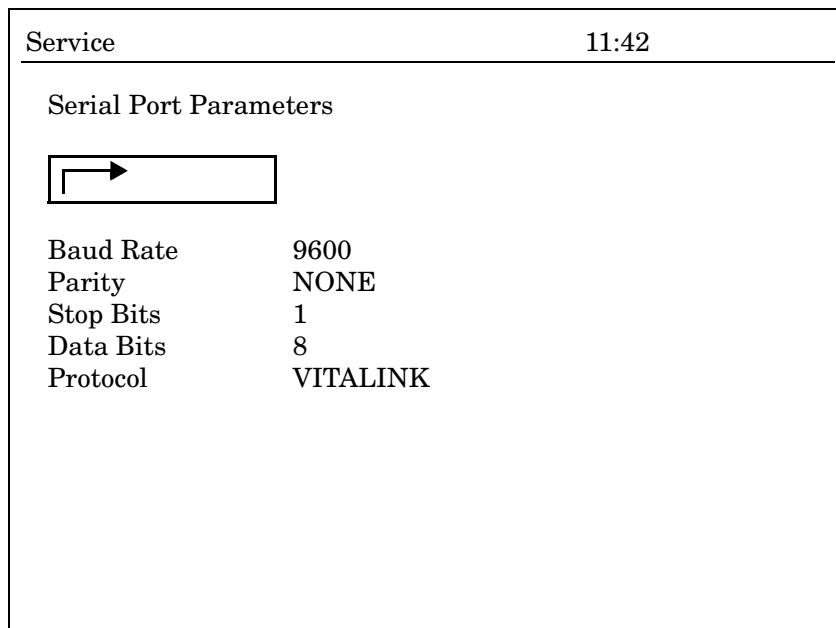

Figure 4-40. Serial Port Parameters Screen

Item	Selections	Factory Default
BAUD RATE	1200, 2400, 4800, 9600, 19200, 38400	9600
PARITY	NONE, ODD, EVEN	NONE
STOP BITS	1 or 2	1
DATA BITS	7, 8	8
PROTOCOL	VITALINK or MEDIBUS	VITALINK

NOTE: It is important to ensure that communication protocols selected on each host and external device are correct. Vitalink and Medibus protocols are similar and if not set identically on each device, inaccurate data may be displayed on the remote device.

To return to the main service screen, scroll to the  and press the knob.

4.9 Pump On/Off

The pump on/off softkey provides the ability to toggle the pump ON or OFF as part of the troubleshooting and diagnostics process.

4.9.1 Access the 'Real Time Values' screen. Refer to Section [4.0](#).

4.9.2 Press the 'PUMP ON/OFF' softkey to toggle the pump between the On and Off state.

NOTE: The pump label located at the bottom left corner of the 'Real Time Values' screen will be highlighted in reverse when the pump has been activated. When first entering the screen, the initial state of the pump is On.

[RETURN TO THIS MANUAL'S TABLE OF CONTENTS](#)
[RETURN TO CD-ROM TABLE OF CONTENTS](#)

5.0 REPLACEMENT PROCEDURES

This section outlines removal and replacement procedures for the field-replaceable assemblies of the Fabius GS Anesthesia System.

These procedures are to be performed only by a qualified technical service representative (TSR).

The following are the only procedures authorized by DrägerService to be performed in the field. All other service procedures shall be referred to Draeger Medical, Inc., DrägerService.

NOTE: The PMS PROCEDURE given in Section 7.0 must be performed after any replacement, removal, calibration or adjustment procedure.

NOTE: The following procedure will require making adjustments and calibrations with the possibility of removal of accessories and/or additional monitoring equipment. Therefore, take note of these devices for reconfiguration and/or reinstallation after the PMS procedure is complete.

5.1 Cylinder Yokes and Regulators

Replacement of a yoke, check valve, or cylinder regulator requires that the yoke be removed from the anesthesia machine. [Figure 5-1.](#) shows the cylinder yokes mounting arrangement. Access to the yoke mounting screws and tubing connections is at the underside of the table top at the back of the machine.

- 5.1.1 Disconnect all pipeline hoses and set the System Power switch to ON.
- 5.1.2 Close all cylinder valves except the O₂ valve.
- 5.1.3 Set the oxygen flow to 5 liters per min.
- 5.1.4 Open the other gas flow control valves to drain pressure from the system.
- 5.1.5 Close the O₂ cylinder valve, and close the flow control valves. Press the O₂ Flush valve to drain oxygen pressure from the system.
- 5.1.6 Set the System Power switch to OFF, disconnect AC power from the machine, and remove any third party monitoring devices, if applicable.
- 5.1.7 Remove the cylinders from the yokes.

WARNING: Ensure the cylinder is stored in a safe place and is laid on its side.

- 5.1.8 Remove the two yoke mounting screws.
- 5.1.9 Hold the check valve assembly with a wrench, and carefully turn the yoke counter-clockwise to remove it.
- 5.1.10 Where applicable, remove the regulator by disconnecting the copper tubing at the HP side of the regulator, and the plastic tubing at the LP side of the regulator. The regulator assembly, with check valve attached, can then be removed from the machine.

NOTE: If a yoke is being replaced, verify that the pin indexing arrangement and the label are in agreement with the gas designation stamped on the mounting surface of the yoke. Refer to the parts list in [Section 9.0](#).

NOTE: Where a regulator is replaced, assemble the fittings and check valve to the regulator with Loctite #271 (red).

- 5.1.11 Install the regulator assembly in the machine. Hold the check valve assembly with a wrench and carefully tighten the yoke to the correct horizontal position.

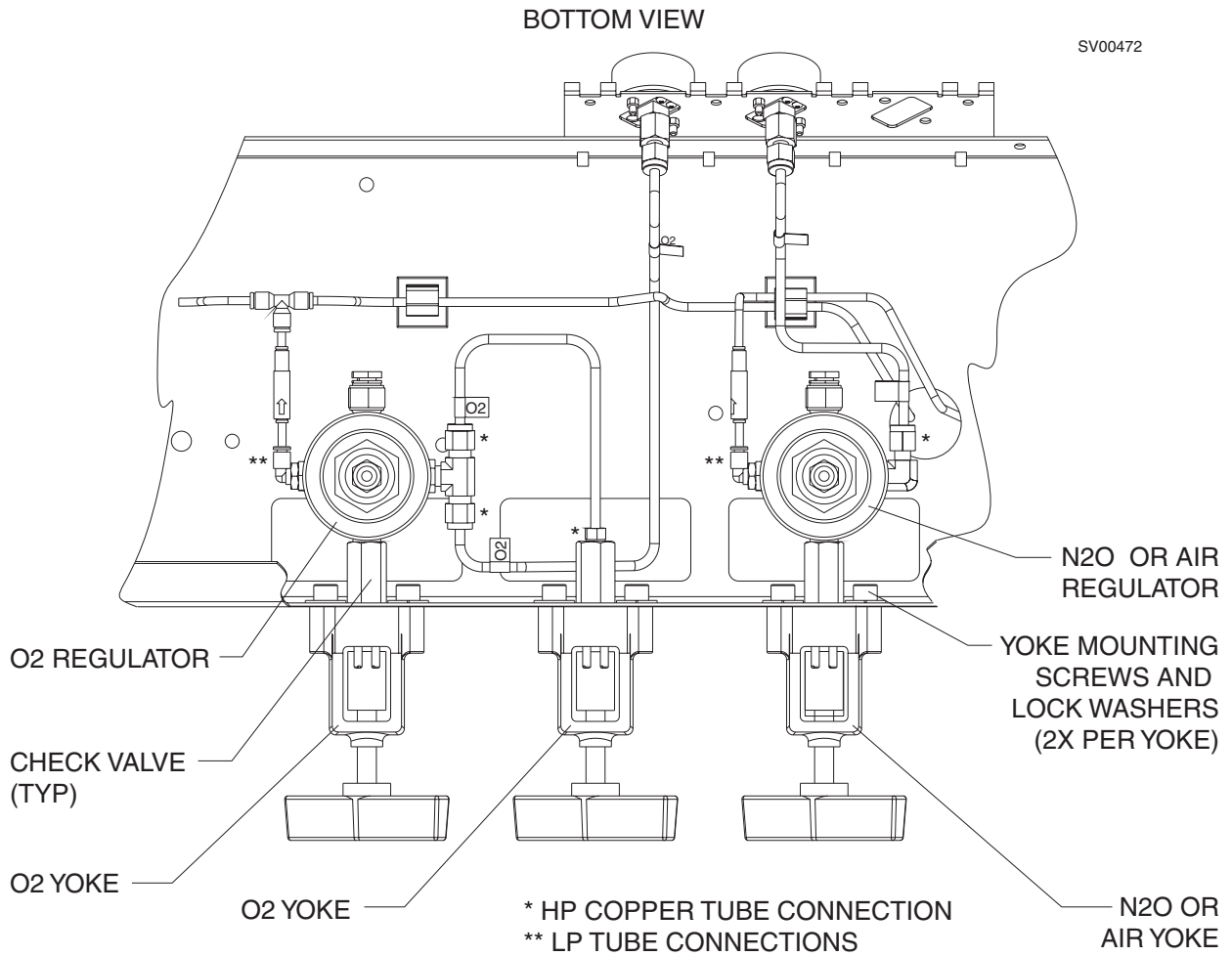

Figure 5-1. Cylinder Yoke and Regulator Assemblies

- 5.1.12 Reattach the yoke to the machine with the hardware previously removed.
- 5.1.13 If a new cylinder is being installed, remove the old sealing washer from the gas inlet of the yoke and install a new washer.
- 5.1.14 Install the correct cylinder on the yoke, making sure that the index pins are properly engaged before tightening the handle bolt. The cylinder should hang vertically after the handle is tight.
- 5.1.15 Perform the following leak test on the yoke assembly:
 - 5.1.15.1 Open the cylinder valve and check for a pressure indication on the corresponding cylinder pressure gauge.
- NOTE:** The cylinder used for this test must contain the following minimum pressure:
 - O₂ : 1000 Psi
 - N₂O : 700 Psi
- 5.1.15.2 Close the cylinder valve and remove the cylinder from the yoke.
- 5.1.15.3 For any gas, the pressure should not drop more than 50 psi in two minutes.
- 5.1.16 Re-install the cylinders on their yokes.
- 5.1.17 Reconnect the pipeline hoses.
- 5.1.18 Restore AC power to the machine and reinstall any third party monitoring devices previously removed.
- 5.1.19 Perform the PMS Procedure given in Section [7.0](#).

5.2 Cylinder Pressure Gauges

Each pressure gauge is secured by two 6-32 keps nuts. As shown in [Figure 5-2](#), access to gauge mounting nuts and tubing connections is at the underside of the table top at the back of the machine.

- 5.2.1 Disconnect all pipeline hoses and set the System Power switch to ON.
- 5.2.2 Close all cylinder valves except the O₂ valve.
- 5.2.3 Set the oxygen flow to 5 liters per min.
- 5.2.4 Open the other gas flow control valves to drain pressure from the system.
- 5.2.5 Close the O₂ cylinder valve, and close the flow control valves. Press the O₂ Flush valve to drain oxygen pressure from the system.
- 5.2.6 Set the System Power switch to OFF, disconnect AC power from the machine, and remove any third party monitoring devices, if applicable.
- 5.2.7 Remove the cylinders from the yokes.

WARNING: Ensure the cylinder is stored in a safe place and is laid on its side.

- 5.2.8 Disconnect the tubing at the back of the gauge.
- 5.2.9 Remove the two keps nuts securing the gauge to its mounting plate.
- 5.2.10 Install the replacement gauge and secure it with the two keps nuts previously removed. Ensure that the replacement gauge is mounted straight onto the mounting plate.
- 5.2.11 Reconnect the tubing.
- 5.2.12 Reinstall the cylinders.

5.2.13 Perform the following leak test:

NOTE: The cylinder used for this test must contain the following minimum pressure:

5.2.13.1 Open the cylinder valve and check for a pressure indication on the corresponding gauge.

O₂ : 1000 Psi

N₂O : 700 Psi

5.2.13.2 Close the cylinder valve and remove the cylinder from the yoke.

5.2.13.3 For any gas, the pressure should not drop more than 50 psi in two minutes.

5.2.14 Reinstall the cylinder on the yoke.

5.2.15 Reconnect the pipeline hoses.

5.2.16 Restore AC power to the machine and reinstall any third party monitoring devices previously removed.

5.2.17 Perform the PMS Procedure given in Section 7.0.

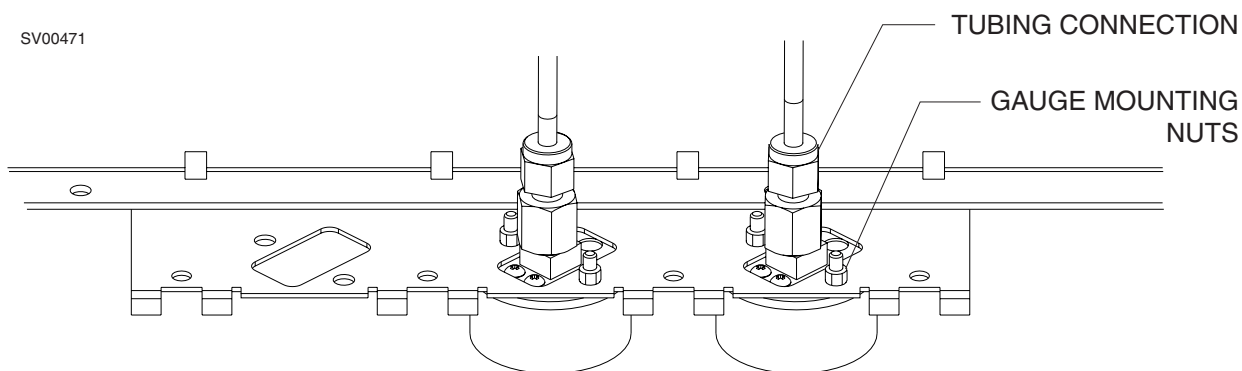

Figure 5-2. Cylinder Pressure Gauges

5.3 Auxiliary Oxygen Flow Meter

The auxiliary oxygen flowmeter is attached to the outside of the ventilator door on the left side of the machine, by a stud and nut arrangement - accessible by opening the door. A flexible O₂ supply tube from the flowmeter connects to a T-fitting below the floor of the ventilator housing. [Figure 5-3.](#) shows the mounting and tubing arrangement.

- 5.3.1 Disconnect all pipeline hoses and close all cylinder valves.
- 5.3.2 Press the O₂ Flush button to drain oxygen pressure from the system.
- 5.3.3 Set the System Power switch to OFF and disconnect AC power from the machine.
- 5.3.4 Open the ventilator door.
- 5.3.5 Cut the tie strap on the flexible tube at the T-fitting, and disconnect the tube.
- 5.3.6 Cut the tie strap on the flexible tube just below the floor of the ventilator housing.
- 5.3.7 Remove the screw nuts securing the auxiliary O₂ flowmeter to the door, and remove the flowmeter.
- 5.3.8 Position the replacement flowmeter on the ventilator door (feed the flex tubing through the clearance hole) and secure the auxiliary O₂ flowmeter with the two nuts that were previously removed.
- 5.3.9 Connect the flex tubing to the T-fitting and secure it with a tie strap.
- 5.3.10 Install a tie strap on the flex tube just below the floor of the ventilator housing.
- 5.3.11 Close and secure the ventilator door.
- 5.3.12 Connect the pipeline hoses and restore AC power to the machine.
- 5.3.13 Perform the PMS Procedure given in [Section 7.0.](#)

SV00475

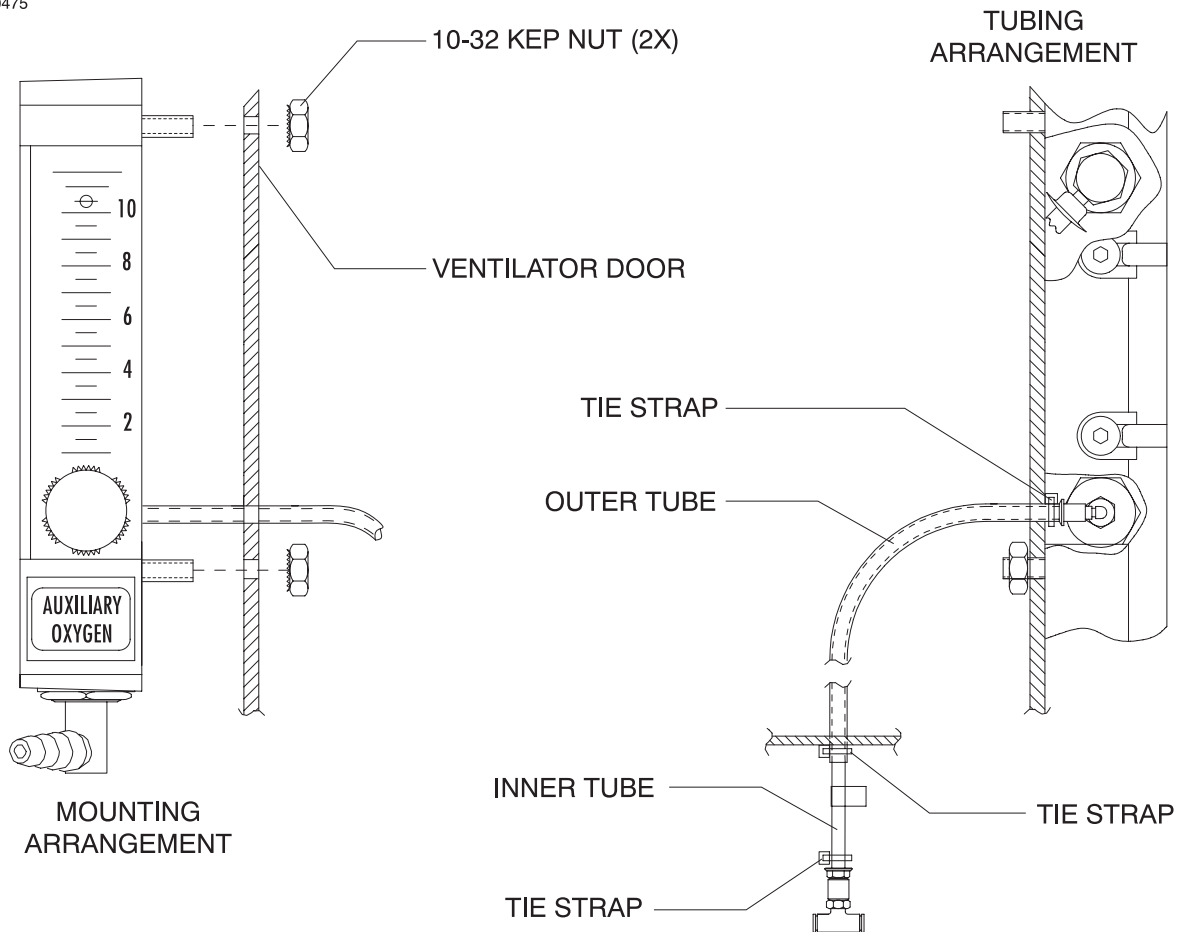

Figure 5-3. Auxiliary O₂ Flowmeter

5.4 Vaporizers

The vaporizer mounting is shown in [Figure 5-4](#). Before removing a vaporizer from the machine for shipment, it must be completely drained and dried in accordance with the procedure given below. Be sure to have a suitable packing or storage container available in which to place the vaporizer.

CAUTION: The following steps must be performed in the sequence given.

WARNING: Do not inhale anesthetic vapors as this could result in personal injury.

WARNING: This procedure must be performed in a well ventilated area and without any other personnel present.

WARNING: For Vapor 19.x series, do not tilt a vaporizer that contains anesthetic agent more than 45 degrees. Failure to observe this precaution will render the handwheel calibration invalid.

- 5.4.1 Set the Main Power switch to ON.
- 5.4.2 Set all vaporizer handwheels to their Zero or OFF position.
- 5.4.3 Remove the filler and drain plugs, and drain the vaporizer into a suitable container. Dispose of the residual agent in an approved manner.
- 5.4.4 Make the necessary machine adjustments to direct gas flow through the breathing system to the scavenger.
- 5.4.5 Verify AGS scavenger is connected to vacuum manifold and AGS is active.
- 5.4.6 Turn the vaporizer handwheel to the maximum concentration setting.
- 5.4.7 Set the oxygen flow to 10 L/min. for at least 20 minutes.
- 5.4.8 Turn the vaporizer handwheel to 0 (zero), and replace the filler and drain plugs.
- 5.4.9 Turn the oxygen flow off, and set the Main Power switch to OFF.
- 5.4.10 Un-lock the vaporizer and carefully lift it from the manifold.
- 5.4.11 Place the vaporizer in a suitable container for transport or storage.

SV00518

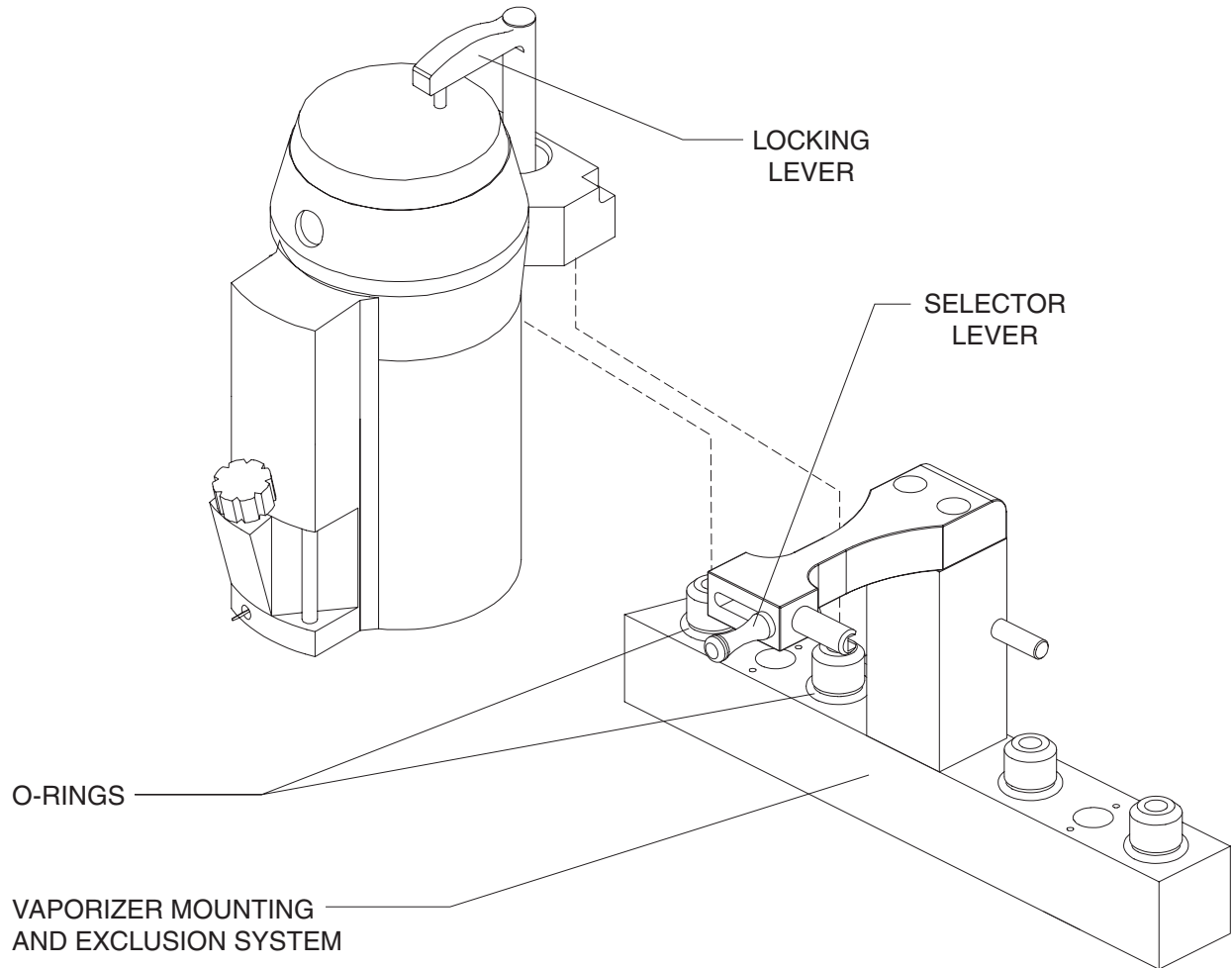

Figure 5-4. Vaporizer Installation

NOTE: Should a 19.x series vaporizer containing anesthetic agent be accidentally tilted more than 45 degrees, it must be drained and flushed in accordance with instructions given in the manual supplied with the vaporizer.

- 5.4.12 Set the handwheel on the replacement vaporizer to its Zero position.
- 5.4.13 Inspect the O-rings on the manifold and replace them if needed.
- 5.4.14 Install the replacement vaporizer on the manifold and turn the locking lever to secure the vaporizer to the manifold.
- 5.4.15 Perform the following test on the interlock mechanism:
 - 5.4.15.1 Move the selector lever to the left. The left vaporizer handwheel should be locked, and the right vaporizer handwheel should be free to turn. Return the right vaporizer handwheel to zero.
 - 5.4.15.2 Move the selector lever to the right. The right vaporizer handwheel should be locked, and the left vaporizer handwheel should be free to turn. Return the left vaporizer handwheel to zero.
- 5.4.16 Perform the PMS Procedure given in Section [7.0](#).

5.5 O2 Flush Valve

The O2 flush valve is accessible from the underside of the table top. Valve removal requires disconnecting the plastic tubing and removal of an L-fitting. [Figure 5-5](#) shows mounting and tubing arrangement for the valve.

- 5.5.1 Set the main power switch to OFF and disconnect AC power from the machine.
- 5.5.2 Disconnect the pipeline hoses.
- 5.5.3 Close the O2 cylinder valve(s).
- 5.5.4 Press the O2 flush valve to drain oxygen pressure from the system.
- 5.5.5 Disconnect the tubing from the straight fitting and from the L-fitting on the O2 flush valve.
- 5.5.6 Remove the L-fitting from the outlet of the O2 flush valve.
- 5.5.7 Un-screw the plastic retaining nut from the valve body, and withdraw the valve from the front of the table.
- 5.5.8 Install the replacement valve in the table top, and secure it with the plastic retaining nut.
- 5.5.9 Install the L-fitting in the valve.
- 5.5.10 Reconnect the tubing to the straight fitting and to the L-fitting.
- 5.5.11 Install the appropriate label on the replacement valve. Refer to [Section 9.0](#) for the correct part number.
- 5.5.12 Reconnect the fresh gas hose to the breathing system.
- 5.5.13 Reconnect the pipeline hoses.
- 5.5.14 Restore AC power to the machine.
- 5.5.15 Perform the PMS Procedure given in [Section 7.0](#).

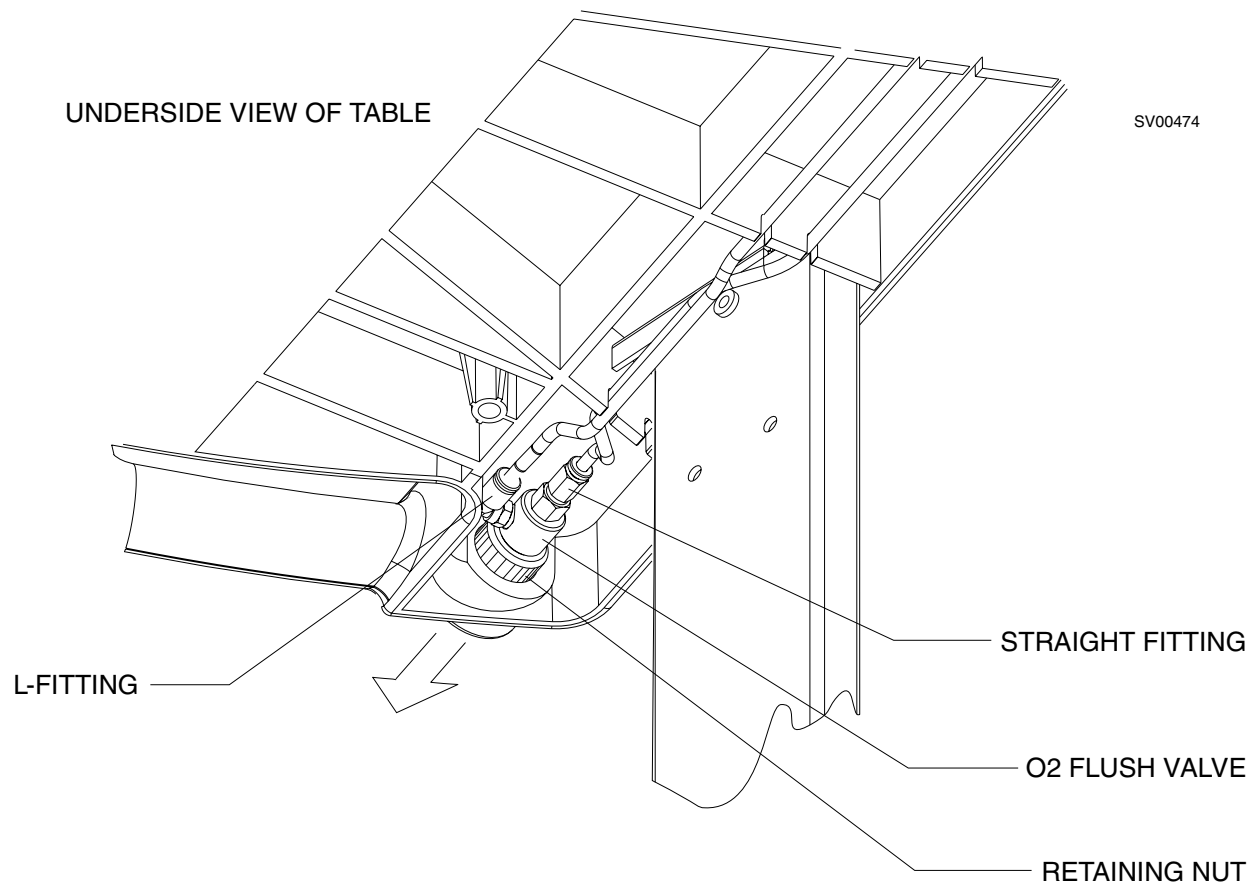

Figure 5-5. O₂ Flush Valve

5.6 Caster

The casters are threaded into the frame rails on the trolley. A typical arrangement is shown in [Figure 5-6](#). Caster replacement requires that the machine be tilted to provide enough clearance for the caster stem to be withdrawn from the frame rail.

WARNING: Do not tilt the machine more than 10 degrees or raise the casters more than 3½ inches from the floor. Failure to observe this precaution may result in a tip-over, causing personal injury. Vaporizers containing anesthetic agent may also be damaged.

- 5.6.1 Obtain a brace capable of supporting one side of the machine with its casters two to three inches from the floor.
- 5.6.2 Remove all unsecured equipment and accessories from the machine.
- 5.6.3 Lock the front casters.
- 5.6.4 Using at least two people, tilt the machine until the casters on one side are raised two to three inches from the floor, and position the support brace under the trolley rail between the front and back casters.
- 5.6.5 Un-screw the caster from the frame using a caster wrench P/N S010055.
- 5.6.6 Apply an ample amount of Loctite (#271 - Red) to the stem of each replacement caster, then thread the caster into the frame and tighten the caster.
- 5.6.7 Using at least two people, tilt the machine, remove the support brace and carefully lower the machine to the floor.
- 5.6.8 Check for proper operation of the caster and ensure that the front casters lock properly.
- 5.6.9 Perform the PMS procedure given in [Section 7.0](#), including a vaporizer calibration verification.
- 5.6.10 Reinstall any unsecured equipment and accessories that were previously removed.

SV00507

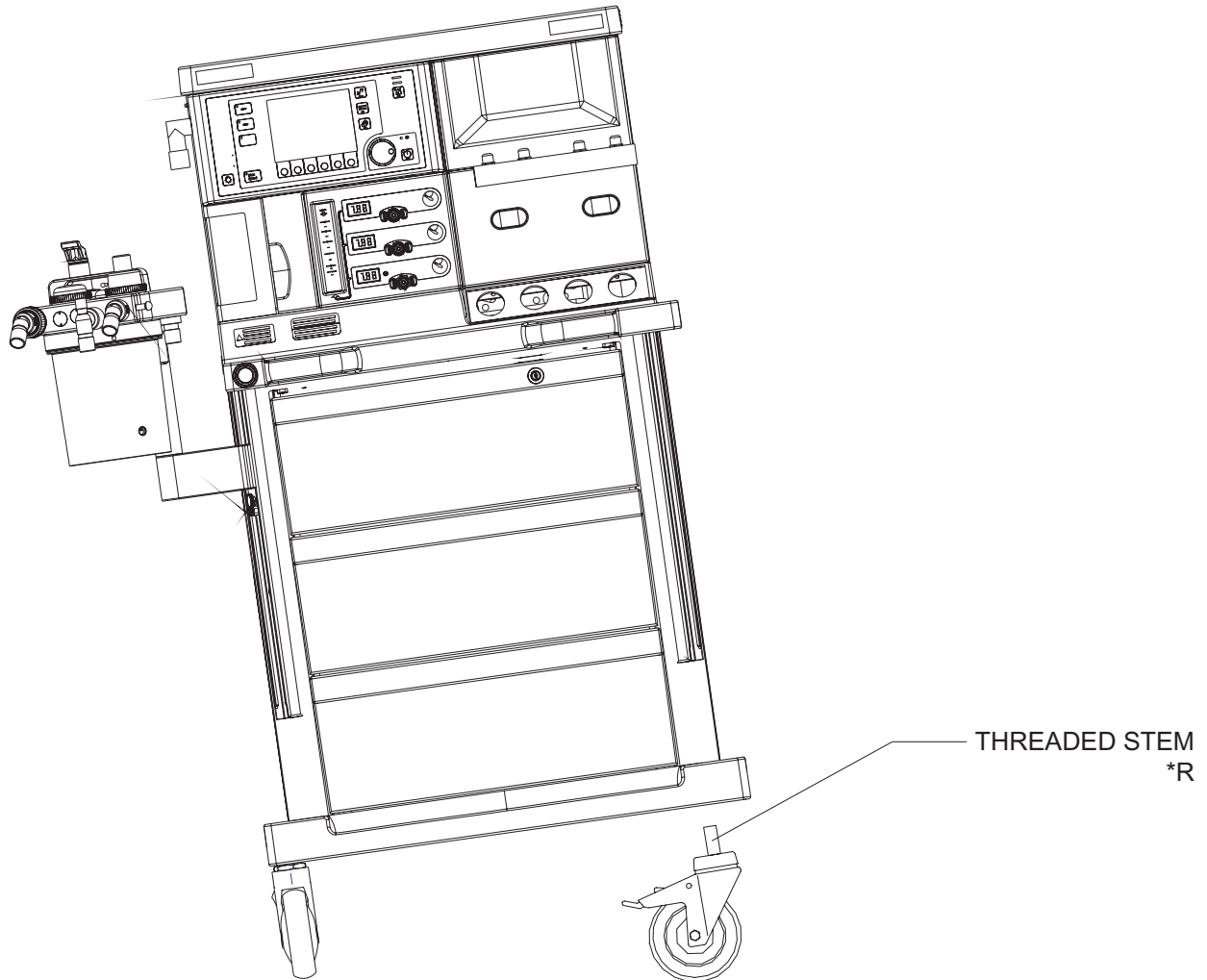

Figure 5-6. Caster Replacement

5.7 Ventilator

The ventilator and door assembly are retained in the monitor housing by a hinge rod. [Figure 5-7.](#) and [Figure 5-8.](#) show the hinge arrangement and the disconnects needed to remove the ventilator from the machine. [Figure 5-9.](#) shows the lower cylinder and motor arrangement. While it is possible to service some components without removing the ventilator assembly from the machine, the complete disassembly sequence is given below.

Ventilator Removal:

- 5.7.1 Set the main power switch to OFF and disconnect AC power from the machine.
 - 5.7.2 Disconnect the ventilator hose at the side of the machine.
 - 5.7.3 Remove the back panel to expose the controller PCB assembly. Provide support for the panel to prevent damage to the power supply cable connections.
- NOTE:** Make note of the positioning and routing of all cables and pneumatic lines for reassembly.
- 5.7.4 Swing open the ventilator door. Disconnect the ventilator cables from J11 and J12 on the controller PCB, and separate the flying connector on the cable attached to J10 on the controller PCB. Feed these three cables forward into the ventilator compartment.
 - 5.7.5 Disconnect the ventilator chamber pressure sensor hose at patient assembly.
 - 5.7.6 Disconnect the ventilator tubing from the T-fitting (see [Figure 5-7.](#)) and feed this tube into the ventilator compartment.
 - 5.7.7 If applicable, disconnect the O2 supply tube from the auxiliary O2 flow meter.
 - 5.7.8 Disconnect the ventilator ground wires from the stud on the ventilator door.
 - 5.7.9 Remove the E-ring from the hinge rod. While supporting the ventilator assembly by the top handle, slide the hinge rod down and out through the underside of the table.
 - 5.7.10 Remove the ventilator from the door by removing Screw A (see [Figure 5-8.](#)) and sliding out the upper and lower hinge bushings.

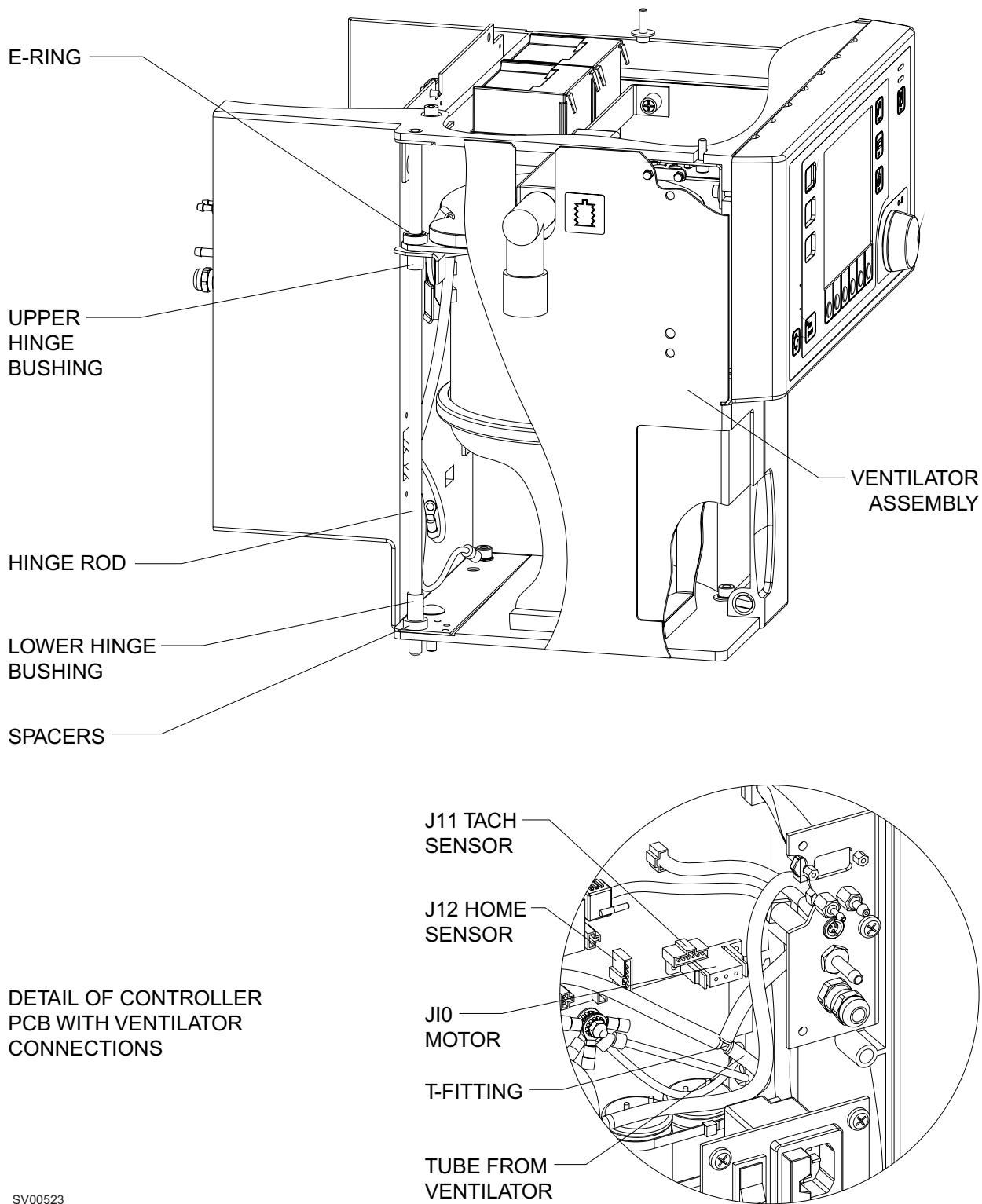

SV00523

Figure 5-7. Ventilator Replacement

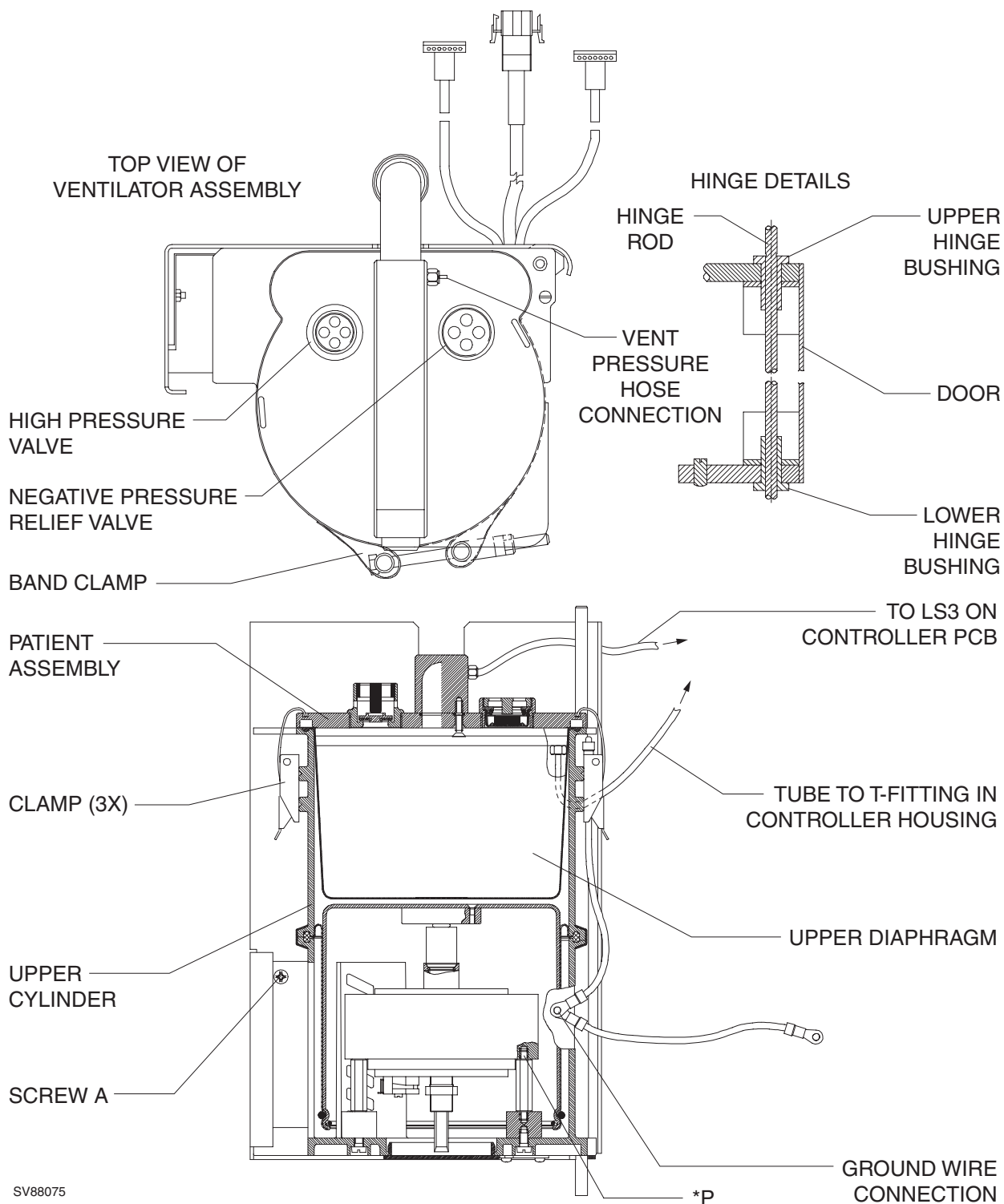

SV88075

*P = LOCTITE # 222 (PURPLE)

Figure 5-8. Ventilator Assembly Details

Ventilator Servicing: Upper Diaphragm (patient side)

- 5.7.11 Release the three clamps holding the patient assembly to the upper cylinder; lift the patient assembly up and out.
- 5.7.12 Lift the diaphragm out of the upper cylinder as shown in [Figure 5-9](#). in the direction of the arrow.

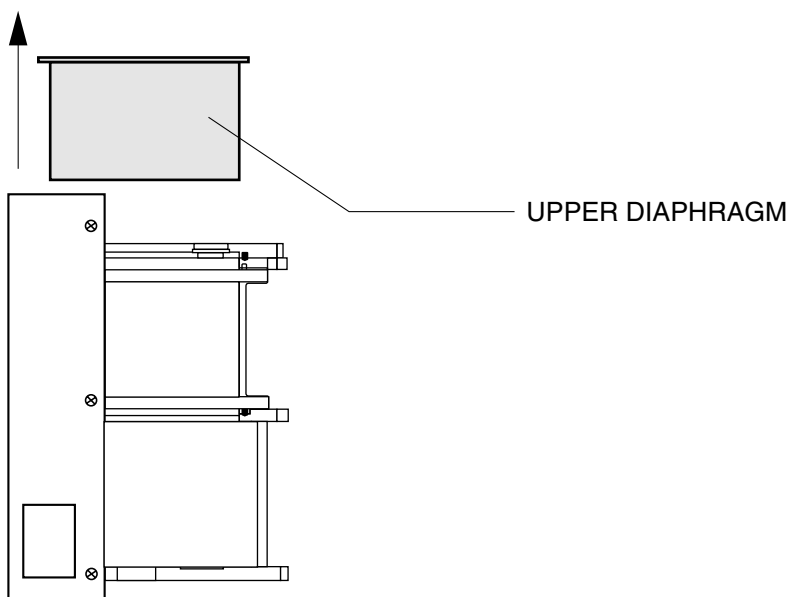

SV00546

Figure 5-9. Upper Diaphragm Removal

- 5.7.13 Lower the replacement diaphragm into the cylinder. ensure that the lip of the diaphragm fits properly into the top groove on the cylinder.
- 5.7.14 Carefully reinstall the patient assembly, making sure the diaphragm seats properly. Secure the three clamps holding the patient assembly to the upper cylinder.

Lower Diaphragm: (motor & case assembly)

- 5.7.15 Note the position of the clamp for reassembly, then remove the bolt securing the band clamp holding the upper and lower cylinders together. Open the band clamp and move it down onto the lower cylinder. Separate the upper cylinder from the lower cylinder.
- 5.7.16 Using the proper "pozi" driver, remove the three screws from the top of the piston. See [Figure 5-12](#).
- 5.7.17 Lift the piston and diaphragm up and out of the lower cylinder.
- 5.7.18 Remove the O-ring off the piston.
- 5.7.19 Place the piston upside down on a table. Remove the retaining ring (circlip) securing the diaphragm at the inside of the piston, and pull the diaphragm up off the piston. See [Figure 5-10](#).

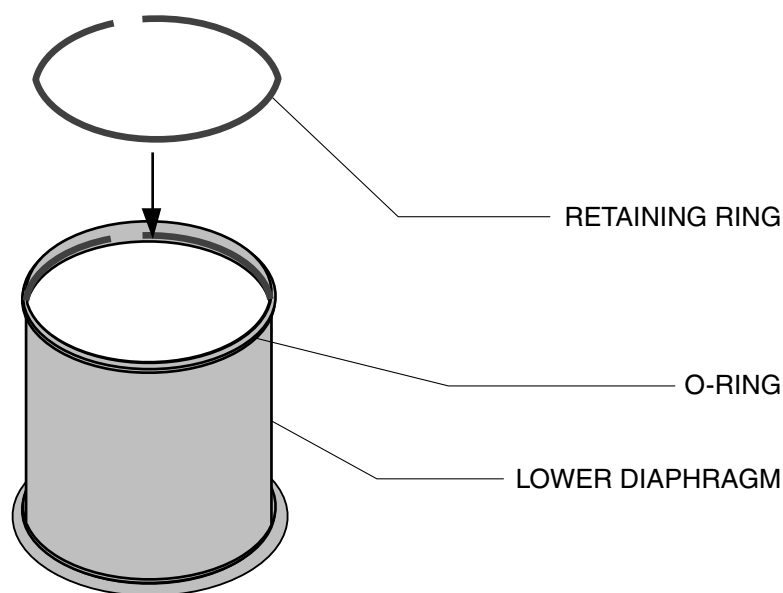

SV00545

Figure 5-10. Lower Diaphragm Removal

- 5.7.20 Install the replacement diaphragm down over the piston; fold the lower lip of the diaphragm (now facing up) over the piston and reinstall the retaining ring in the inner groove of the diaphragm inside the piston. See [Figure 5-10](#). and [Figure 5-12](#).

NOTE: The gap in the retaining ring (circlip) shall be aligned opposite the mark on top of the piston as shown in [Figure 5-12](#). This note does not apply on later units, where the mark on the piston does not exist.

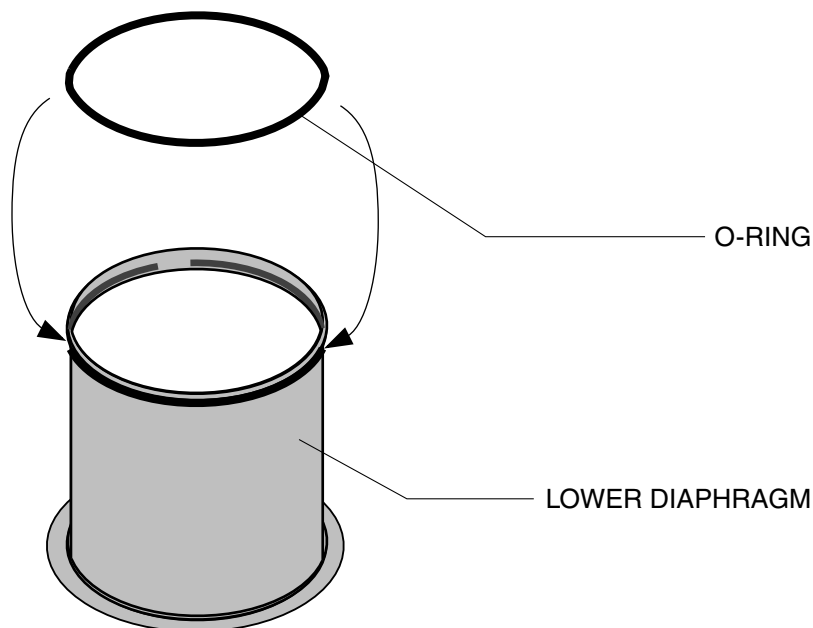

SV00544

Figure 5-11. Lower Diaphragm Installation

5.7.21 Reinstall the O-ring in the groove on the outside of the diaphragm.

5.7.22 Slightly roll the diaphragm down the piston until the diaphragm (overlaps) covers the O-ring evenly around the bottom.

5.7.23 Install the piston over the motor and reinstall the three screws that were previously removed.

NOTE: The lip on the lower diaphragm is captured between the upper and lower cylinders, and must be correctly installed.

5.7.24 Place the upper cylinder on the lip of the diaphragm, and carefully fit the lip into the groove in the upper cylinder.

5.7.25 Carefully press the upper cylinder down until it is resting on the lower cylinder. Note that the cylinders are keyed to fit together in only one position. Look down through the upper cylinder and verify that the lower diaphragm shows a uniform roll around its circumference.

SV88059

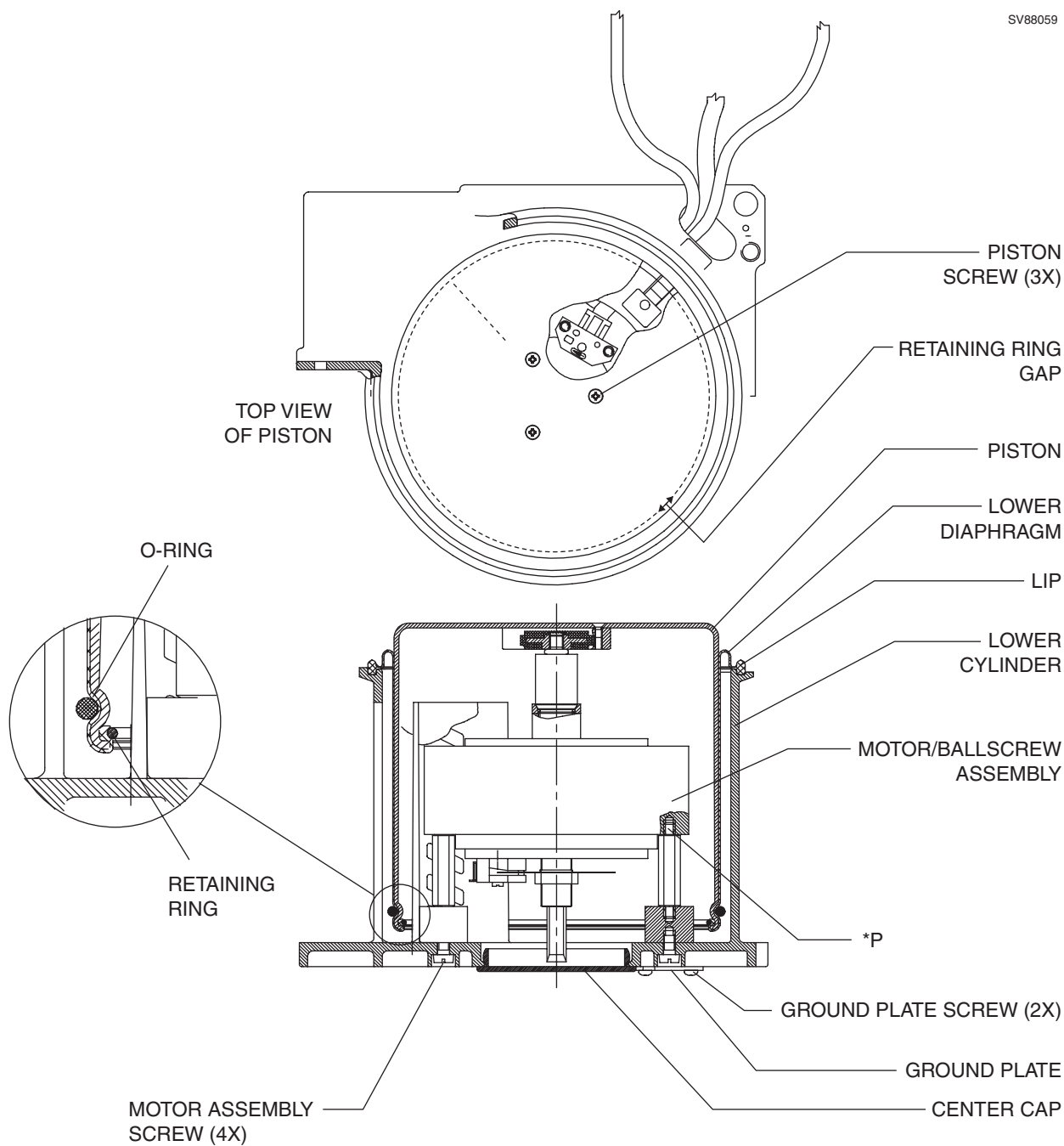

*P = LOCTITE # 222 (PURPLE)

Figure 5-12. Lower Cylinder and Motor Assembly Details

- 5.7.26 While holding the cylinders together, move the band clamp into position and reinstall its bolt to join the cylinders. Make sure the band clamp is positioned as shown in [Figure 5-8](#). or the ventilator door may not close properly.

Motor/Ballscrew Assembly:

NOTE: Upper and lower cylinders must be separated, and piston must be removed.

- 5.7.27 At the bottom of the lower cylinder, remove the ground plate, and remove the center cap.
- 5.7.28 Disconnect and remove the tach cable and positioning sensor cables. Note the arrangement of the cables so they can be reinstalled in the same manner. (The motor cable remains with the motor/ballscrew assembly.)
- 5.7.29 Remove the four screws securing the motor/ballscrew assembly to the lower cylinder. Note the orientation of the unit so the replacement assembly can be installed in the same manner.
- 5.7.30 Remove existing standoffs and shock from removed motor/ballscrew assembly then reinstall onto replacement motor/ballscrew assembly.
- 5.7.31 Install the replacement motor/ballscrew assembly with the hardware that was previously removed.
- 5.7.32 Reinstall the tach and sensor cables. Route all cables in the original manner.
- 5.7.33 Reinstall the ground plate and the center cap.
- 5.7.34 Reinstall the piston.
- NOTE:** The lip on the lower diaphragm is captured between the upper and lower cylinders, and must be correctly installed.
- 5.7.35 Place the upper cylinder on the lip of the diaphragm, and carefully fit the lip into the groove in the upper cylinder.
- 5.7.36 Carefully press the upper cylinder down until it is resting on the lower cylinder. Note that the cylinders are keyed to fit together in only one position. Look down through the upper cylinder and verify that the lower diaphragm shows a uniform roll around its circumference.
- 5.7.37 While holding the cylinders together, move the band clamp into position and reinstall its bolt to join the cylinders. Make sure the band clamp is positioned as shown in the illustration, or the ventilator door may not close properly.

Ventilator Reassembly:

- 5.7.38 Position the ventilator against the door; slide the upper and lower hinge bushings in place, and reinstall Screw A (Figure 5-8.) to attach the ventilator to the door.
- 5.7.39 Locate the hinge rod that was previously removed. Orient it with the E-ring groove toward its upper end. Hold the ventilator assembly by its top handle and position its lower hinge in the monitor housing (make sure the spacers are in place). Sight down through the hinge bushings to align the lower hinge bushing with the hole in the monitor housing. Slide the hinge rod up through the table and up through the lower hinge bushing. Tilt the ventilator assembly into position and continue sliding the rod up and into the upper hole in the monitor housing until the E-ring groove on the rod is visible just above the upper hinge bushing. Reinstall the E-ring on the hinge rod.
- 5.7.40 Feed the three ventilator cables through the opening in the back wall of the ventilator compartment. Reconnect these to J11 and J12 on the controller PCB, and reconnect the remaining one to the flying connector on the cable attached to J10 on the controller PCB.
- 5.7.41 Feed the tubing from the ventilator patient assembly through the opening in the back wall of the ventilator compartment and reconnect it to the T-fitting.
- 5.7.42 Reconnect the vent pressure chamber pressure hose.
- 5.7.43 Re-attach the ground wires to the ventilator door.
- 5.7.44 If applicable, reconnect the O2 supply tube to the auxiliary O2 flow meter.
- 5.7.45 Reinstall the back panel of the controller PCB assembly.
- 5.7.46 Close the ventilator door and restore all external hose connections.
- 5.7.47 Restore AC power to the machine, and test all ventilator functions.
- 5.7.48 Perform the PMS procedure given in Section 7.0.

Patient Assembly:

In case of repair, replace the high pressure valve, the negative pressure relief valve, or the complete patient system. See [Figure 5-8](#).

NOTE: Ensure that the correct Patient Assembly is being installed. Refer to the Spare and Replacement Parts section of this manual to verify the correct assembly per software version of the machine.

- 5.7.49 Disconnect the ventilator hose from the side of the machine.
- 5.7.50 Swing open the ventilator door.
- 5.7.51 Disconnect the ventilator chamber sensor hose.
- 5.7.52 Release the three clamps holding the patient assembly to the upper cylinder, and lift the patient assembly up and out.

High Pressure Valve:

- 5.7.53 Unscrew the high pressure valve using plastic-jaw pliers.
- 5.7.54 Remove all residual thread sealant from the high pressure valve mount on the patient system.
- 5.7.55 Dispose of the old high pressure valve.
- 5.7.56 Apply an ample amount of thread sealant (DI-Wacker Silicon Rubber P/N 1202537) to threads of the new high pressure valve, and screw the high pressure valve into the patient system using plastic-jaw pliers.

Negative Pressure Relief Valve:

NOTE: Ensure that the correct Negative Pressure Relief Valve is being installed. Refer to Section [9.0](#) of this manual to verify the correct valve per software version of the machine.

- 5.7.57 Unscrew the negative pressure relief valve using plastic-jaw pliers.
- 5.7.58 Remove all residual thread sealant from the negative pressure relief valve mount on the patient system.
- 5.7.59 Dispose of the old negative pressure relief valve.
- 5.7.60 Apply an ample amount of thread sealant (DI-Wacker Silicone Rubber P/N 1202537) to threads of the new negative pressure relief valve, and screw the negative pressure relief valve into the patient system using plastic-jaw pliers.

- 5.7.61 Carefully reinstall the patient system, making sure the diaphragm seats properly.
- 5.7.62 Secure the three clamps holding the patient assembly to the upper cylinder.
- 5.7.63 Reconnect the ventilator chamber sensor hose.
- 5.7.64 Reconnect the ventilator hose to the patient system.
- 5.7.65 Close the ventilator door.
- 5.7.66 Perform the PMS procedure given in Section [7.0](#).

5.8 Gas Inlet Assembly (including O2 supply pressure switch)

The gas inlet assembly is attached to the inside of the back panel on the gas box assembly as shown in [Figure 5-13](#). This assembly includes regulators, check valves, filters, and the O2 supply pressure alarm switch. Refer to the parts list in [Section 9.0](#) for details on internal parts locations for replacement.

5.8.1 Set the main power switch to OFF, and close all cylinder valves.

5.8.2 Disconnect AC power from the machine.

5.8.3 Disconnect the pipeline hoses from the machine. Deplete all cylinder and pipeline pressures.

5.8.4 Remove the back panel from the gas box. Provide support for the panel while disconnecting the internal tubing from the gas inlet assembly.

5.8.5 Disconnect the wire harness from the O2 supply pressure alarm switch.

NOTE: Make a note of the connections and their destinations in the following step - for later reassembly.

5.8.6 Disconnect the following tubing:

P1 (N2O pipeline pressure gauge)

P2 (Air pipeline pressure gauge)

P3 (O2 pipeline pressure gauge)

P4 (N2O cylinder regulator output check valve)

P5 (N2O flow control valve)

P6 (Air flow control valve)

P7 (O2 flow control valve)

P8 (O2 T-fitting)

5.8.7 Remove the screws securing the gas inlet assembly to the back panel.

5.8.8 Install the replacement assembly on the back panel in the same manner as the original.

5.8.9 Reconnect the tubing at P1 thru P8.

5.8.10 Reconnect the wire harness to the O2 supply pressure alarm switch.

5.8.11 Reinstall the back panel on the gas box.

5.8.12 Reconnect the pipeline hoses

5.8.13 Perform the PMS procedure given in [Section 7.0](#).

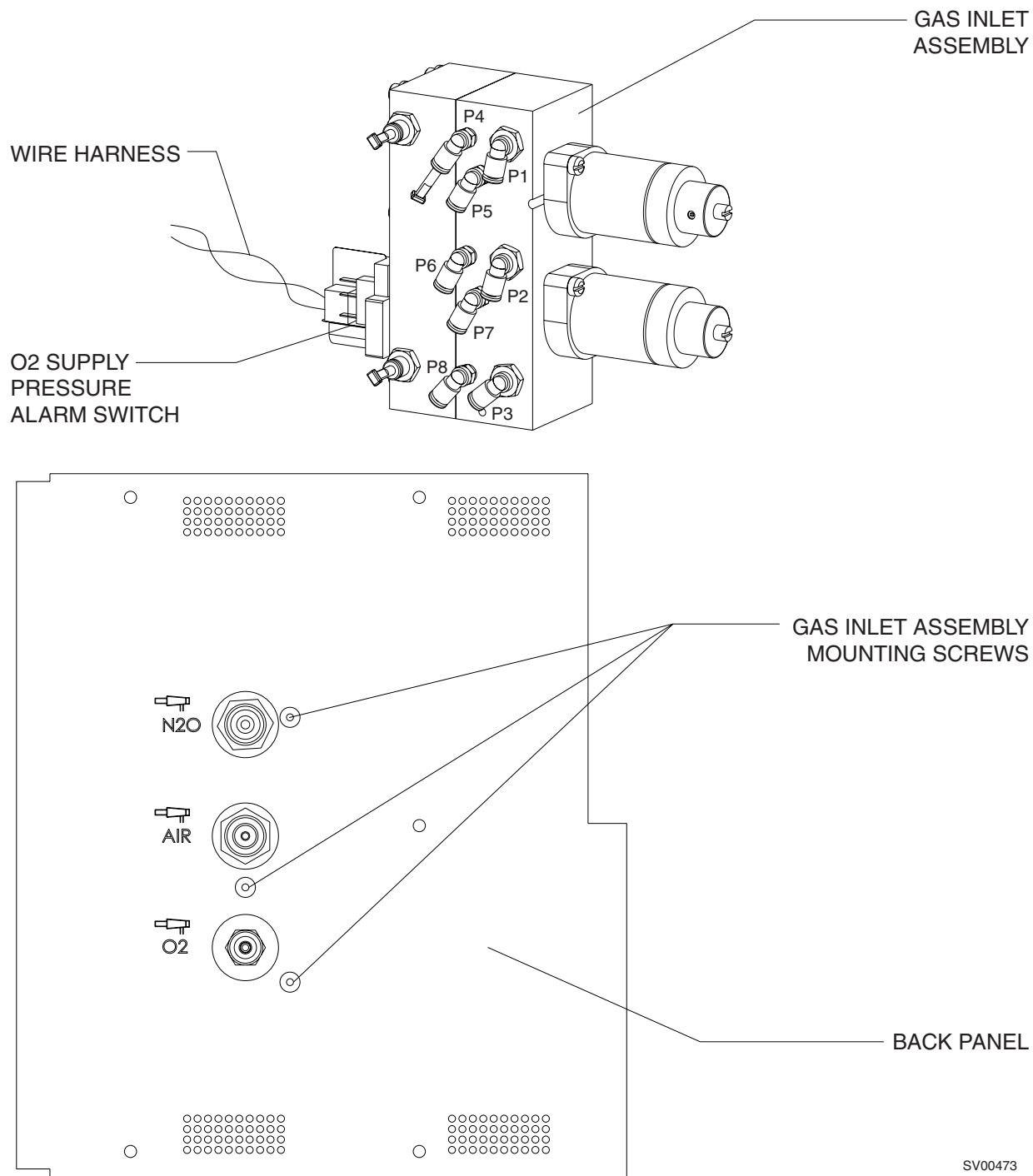

Figure 5-13. Gas Inlet Assembly

5.9 Battery

The two 12 V rechargeable batteries are located in the vent & monitor assembly behind the front bezel. The batteries and their connections are accessible through the ventilator compartment as shown in [Figure 5-14](#).

- 5.9.1 Set the main power switch to OFF and disconnect AC power from the machine.
- 5.9.2 Remove the battery fuse from its holder (located on the back of the machine next to the main power switch).
- 5.9.3 Swing open the ventilator door.
- 5.9.4 Loosen the retainer screw securing the battery retainer bracket. Remove the bracket, and slide the batteries down to the lower level of the ventilator compartment.
- 5.9.5 Note the battery wire harness colors to the battery terminal markings for reconnection. Disconnect the battery wire harness from the battery terminals and remove the batteries.
- 5.9.6 Install the replacement batteries into the lower level of the ventilator compartment with their terminals oriented as shown in the illustration.
- 5.9.7 Reconnect the battery wire harness to the battery terminals. Make sure the connections are as shown in the illustration.
- 5.9.8 Move the batteries up to their original upper position.
- 5.9.9 Reinstall the battery retainer bracket and secure it with the retainer screw.
- 5.9.10 Close the ventilator door.
- 5.9.11 Reinstall the battery fuse and restore power to the machine.
- 5.9.12 Perform the PMS procedure as given in [Section 7.0](#).

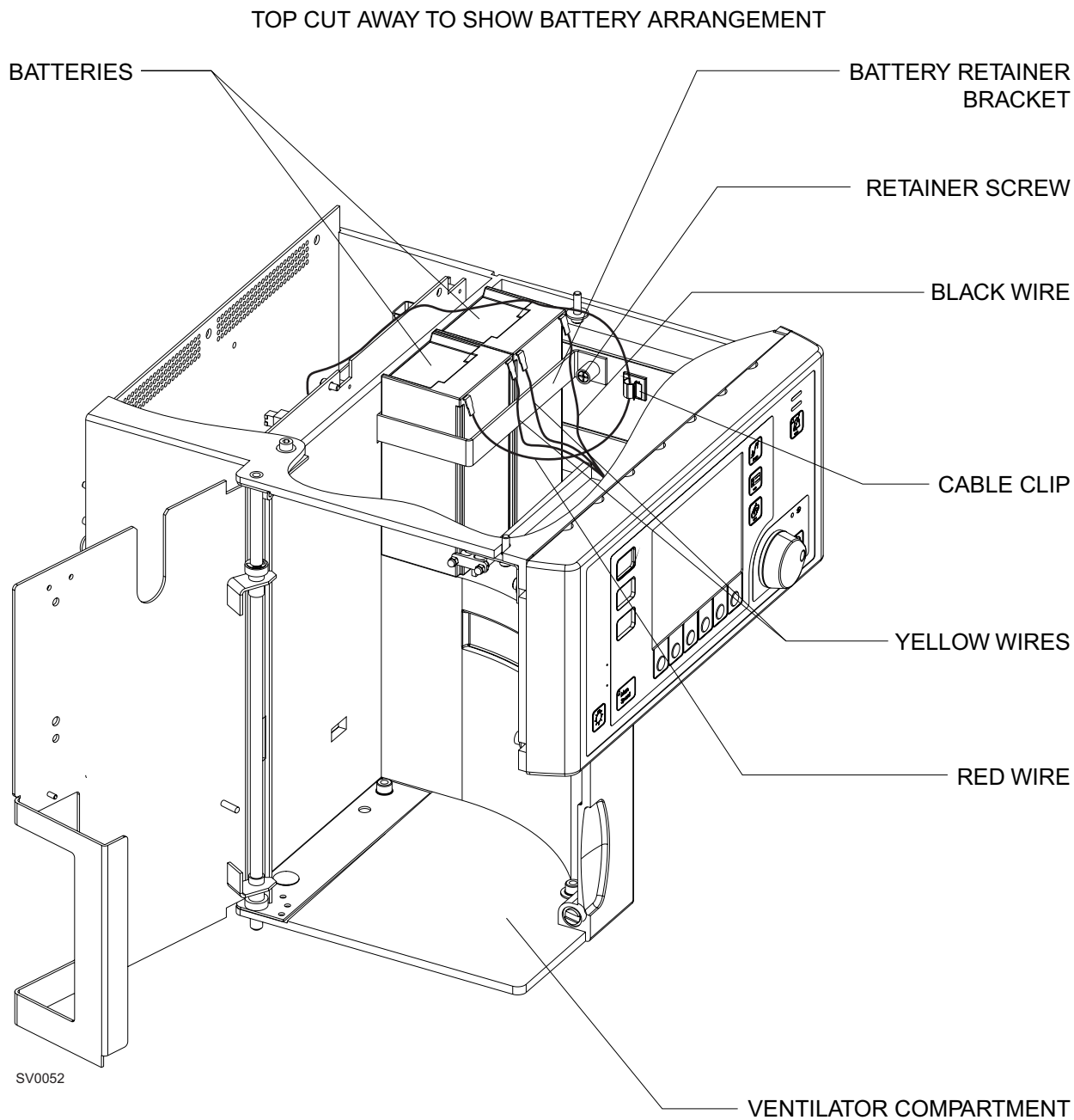

Figure 5-14. Battery Replacement

5.10 Power Supply

The power supply is attached to the inside of the controller assembly back panel. [Figure 5-15](#) shows the mounting and connection arrangement for the power supply.

- 5.10.1 Set the main power switch to OFF and remove AC power from the machine.
- 5.10.2 Remove the screws securing the back panel on the controller assembly; while supporting the panel, carefully open it as shown in the illustration.

CAUTION: The power supply contains static sensitive devices. Use ESD protection while handling this assembly.

- 5.10.3 Disconnect the input cable from J1 on the power supply, and disconnect the output cable from J3 on the power supply.
- 5.10.4 Disconnect the ground wire from the back panel. Remove the wires from the cable clips, and separate the panel from the machine.
- 5.10.5 Remove the two power supply mounting screws and lock washers holding the power supply to the panel.
- 5.10.6 Install the replacement power supply on the panel - oriented as shown in the illustration.
- 5.10.7 While supporting the panel, reconnect the ground wire, and reconnect the input and output cables to the power supply at J1 and J3.
- 5.10.8 Place the wires back in their cable clips.
- 5.10.9 Reinstall the back panel on the controller assembly.
- 5.10.10 Restore AC power to the machine.
- 5.10.11 Set the main power switch to ON and verify that the power-up sequence is successfully completed.
- 5.10.12 Perform the PMS procedure given in [Section 7.0](#).

SV00464

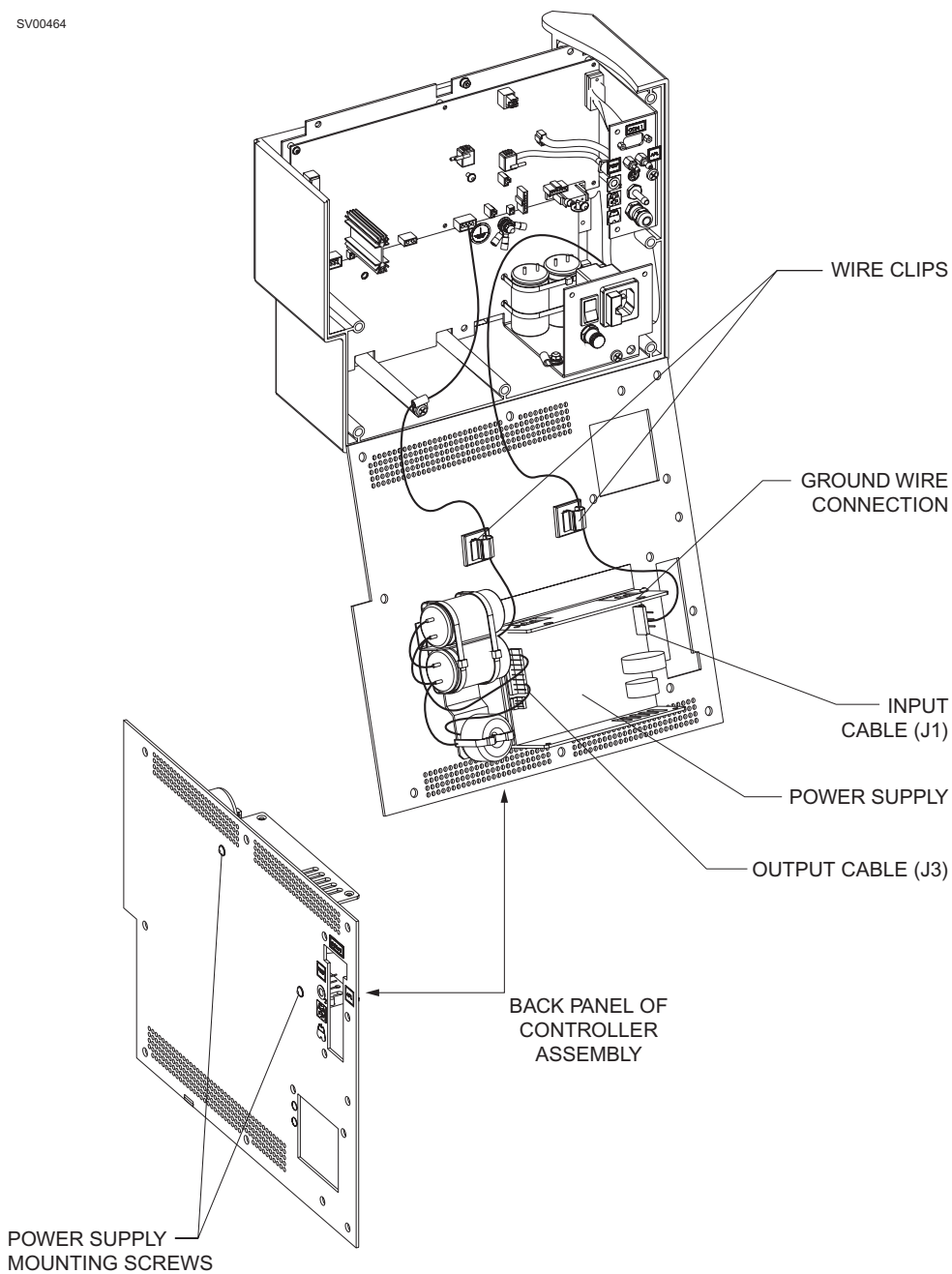

Figure 5-15. Power Supply

5.11 Control PCB Assembly

The control PCB assembly is accessible by removing the back cover of the controller housing. [Figure 5-16.](#) and [Figure 5-17.](#) shows the mounting arrangement and electrical connections to this assembly.

NOTE: Verify the original software level of the PCB prior to removal. Replacement control PCBs may contain a different software level, a software update may be necessary. If applicable, perform a software download in accordance with the applicable Software Upgrade Service Procedure after the replacement PCB is installed.

5.11.1 If possible, record the market settings on the unit for re-configuration of the replacement PCB. Refer to [Section 4.0](#) to access the appropriate service screen. If these settings can not be displayed, refer to the tables below for the settings that correspond to your region.

NOTE: The following step is applicable on units with Software Version 2.X.

5.11.2 If applicable, record the Device ID number, Machine Serial number, and Release Code number located in the Secure Options screen in the Main Service menu for all ventilator feature option(s) that are enabled, for reconfiguration of the replacement processor.

5.11.3 Set the main power switch to OFF and disconnect AC power from the machine.

5.11.4 Remove the back panel from the controller housing. Provide support for the panel to prevent damage to the power supply cable connections.

CAUTION: The control PCB contains static sensitive devices. Use ESD protection when handling this assembly.

5.11.5 Disconnect all of the cables from the board connectors indicated in the illustration. Also disconnect the tubing from the pressure sensors on the PCB.

5.11.6 Remove the screws holding the PCB assembly to the controller housing, and carefully remove the PCB assembly.

5.11.7 Install the replacement PCB assembly with the hardware that was previously removed.

NOTE: Verify jumper at JP3 is installed on both pins. This activates the 3V lithium battery (BT1) for the non-volatile RAM.

5.11.8 Reconnect all of the cables and hoses that were previously disconnected.

NOTE: Replacement PCB's come with a new hose attached to the LS2 pressure sensor. Remove and discard the original 2-hose assembly from the breathing pressure interface panel connector inside the unit and attach the new hose to the breathing pressure interface connector.

- 5.11.9 Reinstall the back panel on the controller housing.
 - 5.11.10 Restore power to the machine and observe the power -up diagnostic display (see Section 4.0) to verify that the replacement PCB is working properly.
 - 5.11.11 Access the appropriate service screen and update the machine serial number, clear service log and reset hours run. The machine serial number is located on the rear of the machine.
 - 5.11.12 Perform the market settings per the original machine configuration or customer requirements.
- NOTE:** The default “Market Selection” for the replacement PCB is “U.S.” To change the language and pressure measurement units, the “Market Selection” must be changed to “Non-U.S. (see Section 4.0). The market kit setting will vary depending upon the current software installed on the machine. [Table 1:](#) is to be used for SW Versions 1.2n and 1.3n and [Table 2:](#) is to be used for SW Version 2.X. Refer to the appropriate table for the market settings that correspond to your region.
- 5.11.13 Enter the System Service Screen. If hardware 4118079 is listed, perform Pump Calibration procedure in accordance with Section 6.10.
 - 5.11.14 If applicable, to enable previously configured ventilator option(s), contact DrägerService - Technical Support: Phone 1-800-4-Dräger, Phone: 215-721-5402, or e-mail to techsupport@draegermed.com and provide the following information to receive the necessary release codes:
 - Machine Type (Fabius GS or Fabius Tiro)
 - Feature Description and Part Number
 - Machine Serial Number
 - Device ID Number
 - 5.11.15 Perform the PMS procedure, including all calibrations and site configurations, given in Section 7.0.

Table 1: Default Market Kit Settings for SW Versions 1.2n and 1.3n

	O2 Whistle	Language	Date Format	Time Format	O2 Position	Alarm Sounds	Pres. Units
USA	Disabled	English	M/D/Y	12 Hour	Right	Drager	cmH2O
UK/Ireland	Enabled	UK English	D/M/Y	24 Hour	Left	EN740	mbar
France	Enabled	French	D/M/Y	24 Hour	Left	EN740	mbar
Germany	Enabled	German	D/M/Y	24 Hour	Left	EN740	mbar
Spain	Enabled	Spanish	D/M/Y	24 Hour	Left	EN740	mbar
Poland	Enabled	Polish	D/M/Y	24 Hour	Left	EN740	mbar
Italy	Enabled	Italian	D/M/Y	24 Hour	Left	EN740	mbar
Netherlands	Enabled	Dutch	D/M/Y	24 Hour	Left	EN740	mbar
Russia	Enabled	Russian	D/M/Y	24 Hour	Left	EN740	mbar
Sweden	Enabled	Swedish	D/M/Y	24 Hour	Left	EN740	mbar
Romania	Enabled	Romanian	D/M/Y	24 Hour	Left	EN740	mbar
Canada	Enabled	English	M/D/Y	12 Hour	Right	Drager	cmH2O
Egypt	Enabled	English	D/M/Y	24 Hour	Left	EN740	mbar
Mexico	Enabled	Spanish	D/M/Y	24 Hour	Right	Drager	mbar
Australia	Enabled	English	D/M/Y	24 Hour	Left	EN740	mbar
Hungary	Enabled	Hungarian	D/M/Y	24 Hour	Left	EN740	mbar
Turkey/Yugoslavia	Enabled	UK English	D/M/Y	24 Hour	Left	EN740	mbar
Belgium/Luxembourg	Enabled	French	D/M/Y	24 Hour	Left	Drager	mbar
Brazil	Enabled	Portuguese	D/M/Y	24 Hour	Right	EN740	mbar
Bulgaria/Finland	Enabled	UK English	D/M/Y	24 Hour	Left	EN740	mbar
Chile	Enabled	Spanish	D/M/Y	24 Hour	Right	EN740	mbar
Croatia	Enabled	Croatian	D/M/Y	24 Hour	Left	EN740	mbar
Cuba	Enabled	Spanish	D/M/Y	24 Hour	Right	Drager	mbar
Czech Republic	Enabled	Czech	D/M/Y	24 Hour	Left	EN740	mbar
Guam/Samoa	Enabled	UK English	D/M/Y	24 Hour	Left	EN740	mbar
Jamaica	Enabled	UK English	D/M/Y	24 Hour	Left	EN740	mbar
Paraguay	Enabled	Spanish	D/M/Y	24 Hour	Right	EN740	mbar
Portugal	Enabled	Portuguese	D/M/Y	24 Hour	Left	EN740	mbar
Slovak Republic	Enabled	Slovak	D/M/Y	24 Hour	Left	EN740	mbar
Switzerland	Enabled	German	D/M/Y	24 Hour	Left	EN740	mbar
Thailand	Enabled	UK English	D/M/Y	24 Hour	Left	EN740	mbar
Uruguay	Enabled	Spanish	D/M/Y	24 Hour	Right	Drager	mbar
Vietnam	Enabled	UK English	D/M/Y	24 Hour	Right	EN740	mbar
Argentina	Enabled	Spanish	D/M/Y	24 Hour	Right	Drager	cmH2O

Table 2: Default Market Kit Settings for SW Version 2.X

	O2 Whistle	Language	Date Format	Time Format	O2 Position	Alarm Sounds	Pres. Units
USA	Disabled	English	M/D/Y	12 Hour	Right	Drager	cmH2O
Germany	Enabled	German	D/M/Y	24 Hour	Left	EN740	mbar

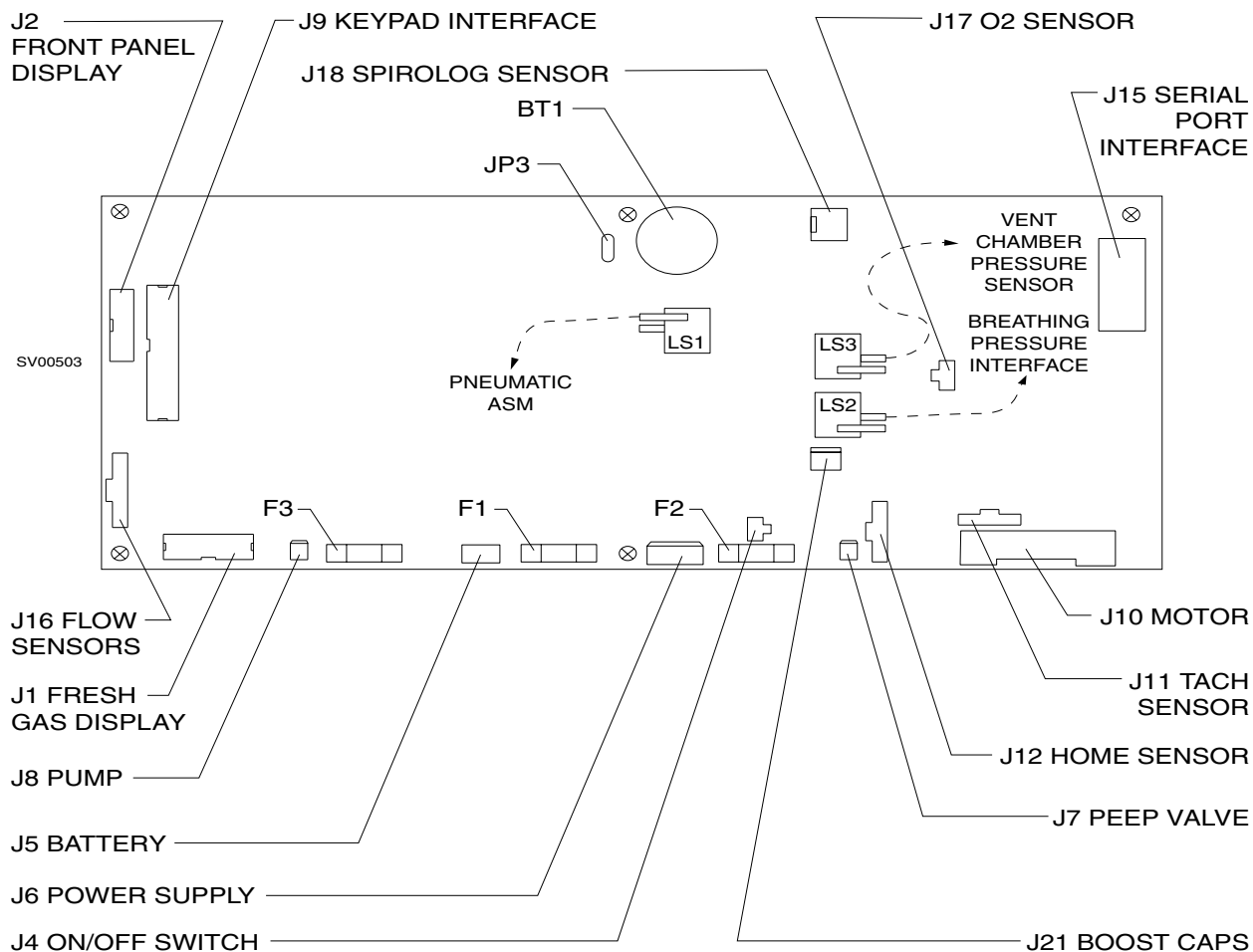

Figure 5-16. Control PCB Assembly, P/N 4116632

5.12 Pneumatic (PEEP Control) Assembly

The Pneumatic assembly is accessible by removing the back cover of the controller housing. 5.13 shows the mounting, tubing and electrical connections for this assembly.

- 5.12.1 Set the main power switch to OFF and disconnect AC power from the machine.
- 5.12.2 Remove the back panel from the controller housing. Provide support for the panel to prevent damage to the power supply cable connections.
- 5.12.3 Disconnect the following items:
 - Pump cable at J8 on controller PCB
 - PEEP cable at flying connector (from J7)
 - Small dia tubing at LS1 sensor on controller PCB
 - PEEP hose at hose pneumatic assembly PEEP valve
 - Vacuum hose at pneumatic assembly reservoir
- 5.12.4 Loosen the captive mounting screw on the pneumatic assembly.
- 5.12.5 Remove the rear mounting screw and carefully slide the assembly out of the controller housing. (Make sure the back panel with the power supply attached is supported to prevent damage to its connections.)

NOTE: If only the pump is being replaced, pump replacements on machine with serial numbers \leq 11867 require a pump retrofit kit, P/N 4118407.

- 5.12.6 If installing a pump retrofit kit, proceed with the following steps. If a pump retrofit kit is not required, skip to step 5.12.7.
 - 5.12.6.1 Removal of the Motor Pump from the Pneumatic Assembly (See Figure 5-18.):
 - 5.12.6.1.1 Disengage the three damper devices from the fixing plate.

NOTE: Do not remove the damper devices from the PEEP bracket.
 - 5.12.6.1.2 Remove and discard the existing Motor Pump Assembly.

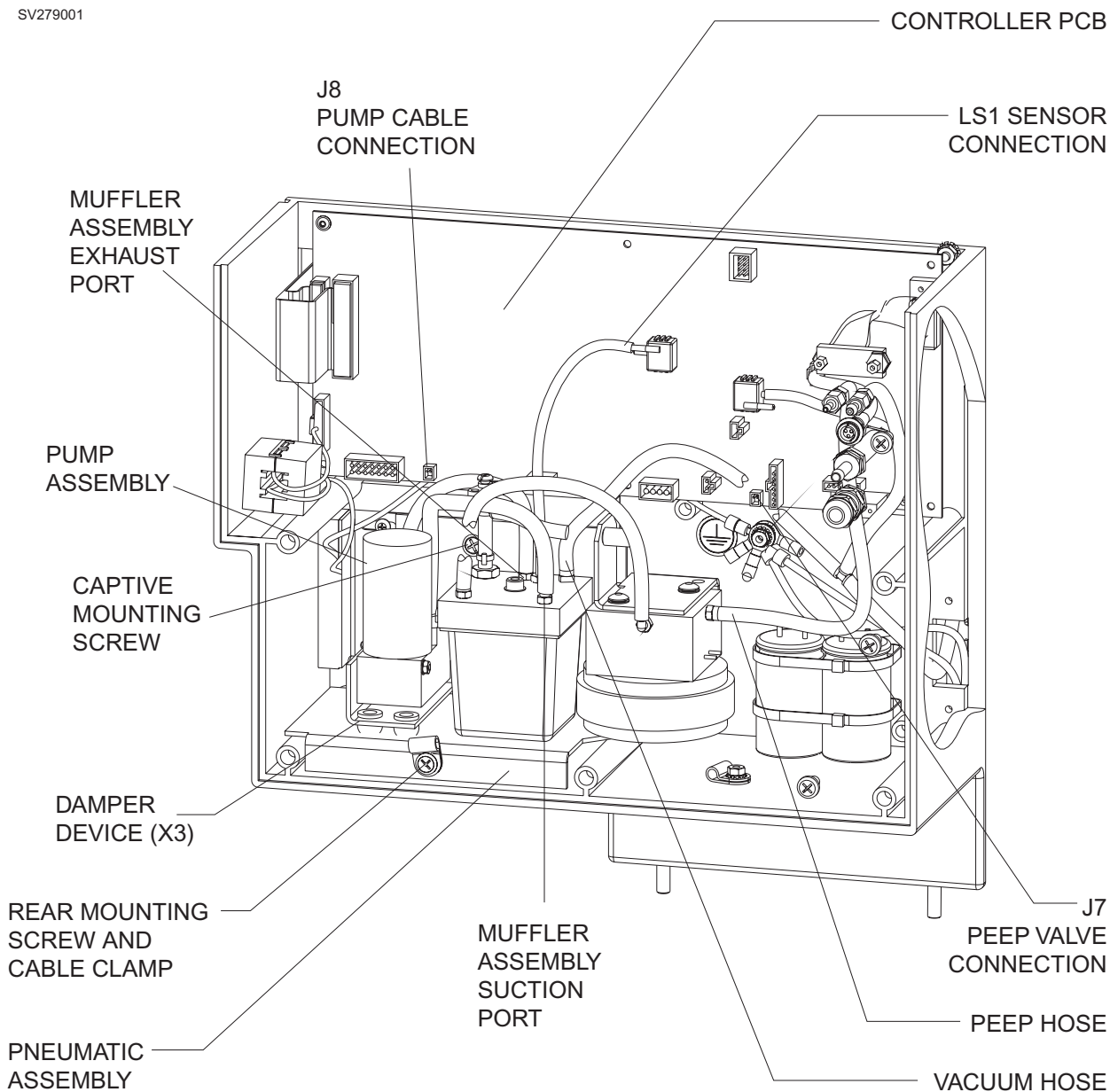
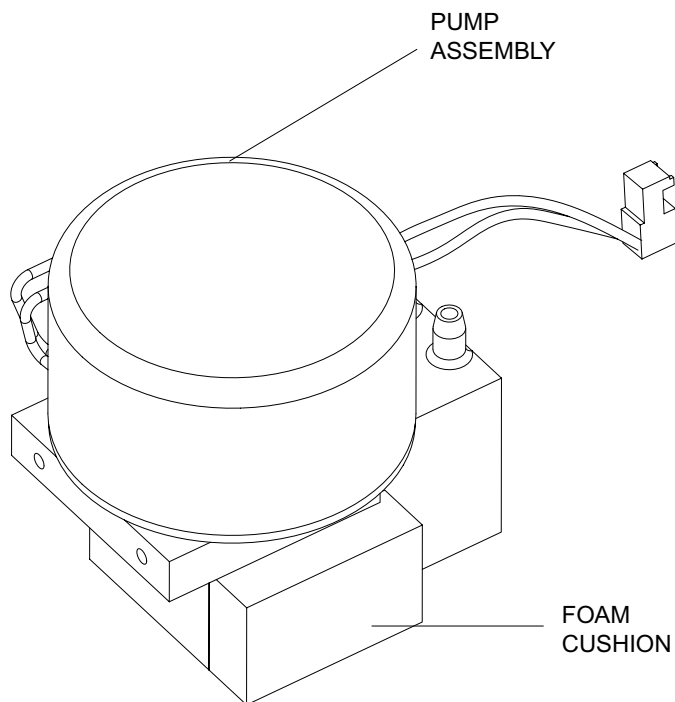

Figure 5-18. Removal of Pneumatic Assembly and Motor Pump

5.12.6.2 Installation of the Foam Cushion:

- 5.12.6.2.1 Remove the adhesive backing from the foam cushion (P/N 4118174) and attach the cushion to the underside of the new Motor Pump Assembly. Refer to [Figure 5-19](#).



SP279002

Figure 5-19. Foam Cushion Installation

- 5.12.6.3 Installation of the New Motor Pump to the Pneumatic Assembly (See [Figure 5-20](#).):

- 5.12.6.3.1 Secure three previously disconnected damper devices to the underside of the pump adapter mounting bracket (P/N 4118159).
- 5.12.6.3.2 Apply a thin coating of #242 blue Loctite to three cap socket head screws (P/N HW01028).
- 5.12.6.3.3 Install three flat washers (P/N HW66003) onto the cap socket head screws.
- 5.12.6.3.4 Insert cap socket head screws and flat washers through the top of the dampers, through the pump adapter mounting bracket, and then through the bottom of the fixing plate.
- 5.12.6.3.5 Secure the three cap socket head screws with three acorn nuts (P/N HW51000) on the underside of the fixing plate.

5.12.6.3.6 Apply a thin coating of #222 purple Loctite to two pan head screws (P/N 1343068).

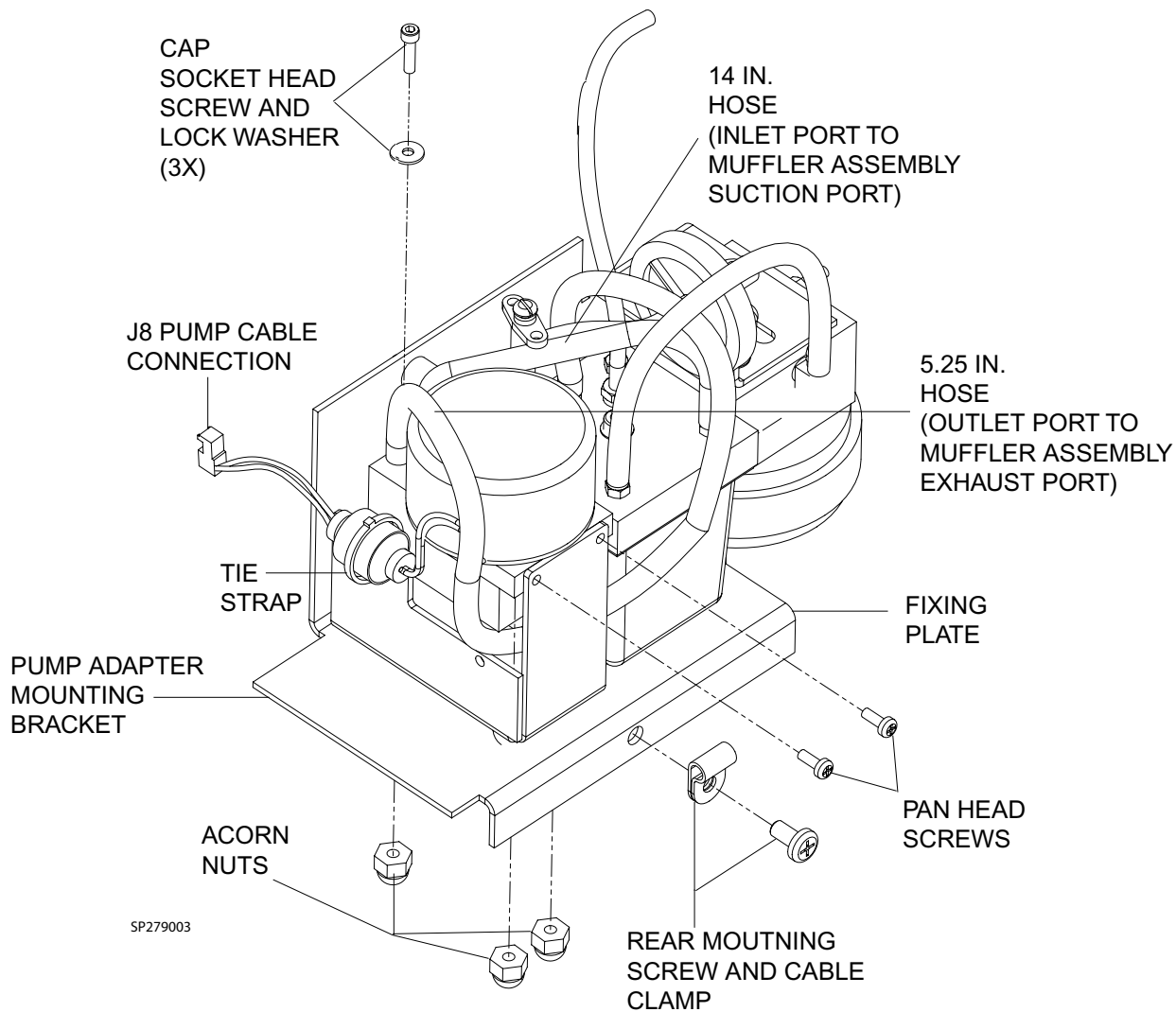

Figure 5-20. Installation of New Motor Pump Assembly

- 5.12.6.3.7 Using the two pan head screws, attach the Motor Pump Assembly to the Pump Adapter Mounting Bracket.
- 5.12.6.3.8 Secure ferrule from Motor Pump Assembly to Pump Adapter Mounting Bracket using tie strap (P/N 4106068).
- 5.12.6.3.9 Install 14 in. hose (P/N 1190520) from inlet port of Motor Pump Assembly to suction port of Muffler Assembly. (Refer to Figure 1 for Muffler Assembly connection locations)
- 5.12.6.3.10 Install 5.25 in. hose (P/N 1190520) connecting to outlet port of Motor Pump Assembly to exhaust port of Muffler Assembly.
- 5.12.7 Slide the replacement pneumatic assembly into the controller housing and secure it with the captive mounting screw. reinstall the rear mounting screw and cable clamp.
- 5.12.8 Reconnect the items that were previously disconnected:
 - Pump cable at J8 on controller PCB
 - PEEP cable at flying connector
 - Small dia tubing at LS1 sensor on controller PCB
 - PEEP hose
 - Vacuum hose
- 5.12.9 Reinstall the back panel on the controller assembly.
- 5.12.10 Restore AC power to the machine.
- 5.12.11 Enter the System Service Screen. If hardware 4118079 is listed, perform Pump Calibration procedure in accordance with Section 6.10.
- 5.12.12 Perform the PMS procedure given in Section 7.0.

5.13 Flow Meter Bezel Assembly

Following is the procedure for removing and replacing the flow meter bezel assembly. See [Figure 5-21](#). This assembly comprises the fresh gas flow meter, flow control valves, flow sensors and filter, pipeline pressure gauges, SORC, and the fresh gas display PCB. Replacement procedures for these individual sub-assemblies are given in subsequent paragraphs.

- 5.13.1 Set the main power switch to OFF and disconnect AC power from the machine.
- 5.13.2 Disconnect the pipeline and cylinder supplies, and deplete all pressures.
- 5.13.3 Remove the two screws at the back of the machine securing the flow meter bezel assembly.
- 5.13.4 At the front of the machine, carefully pull the assembly forward about 2.5 inches. Disconnect the ribbon cable and the O2 alarm switch wire harness from the fresh gas display PCB, and disconnect each flow sensor cable. Continue to pull the assembly forward.

The individual sub-assemblies can now be serviced as described in subsequent paragraphs.

-
- 5.13.5 When reinstalling the flow meter bezel assembly, push the assembly into its compartment; reattach the ribbon cable and the O2 alarm switch wire harness to the fresh gas display PCB, and reconnect each flow sensor cable. Continue to push the assembly into its compartment until it is fully seated.
 - 5.13.6 Reinstall the two screws at the back of the machine to secure the flow meter bezel assembly.

SV00506

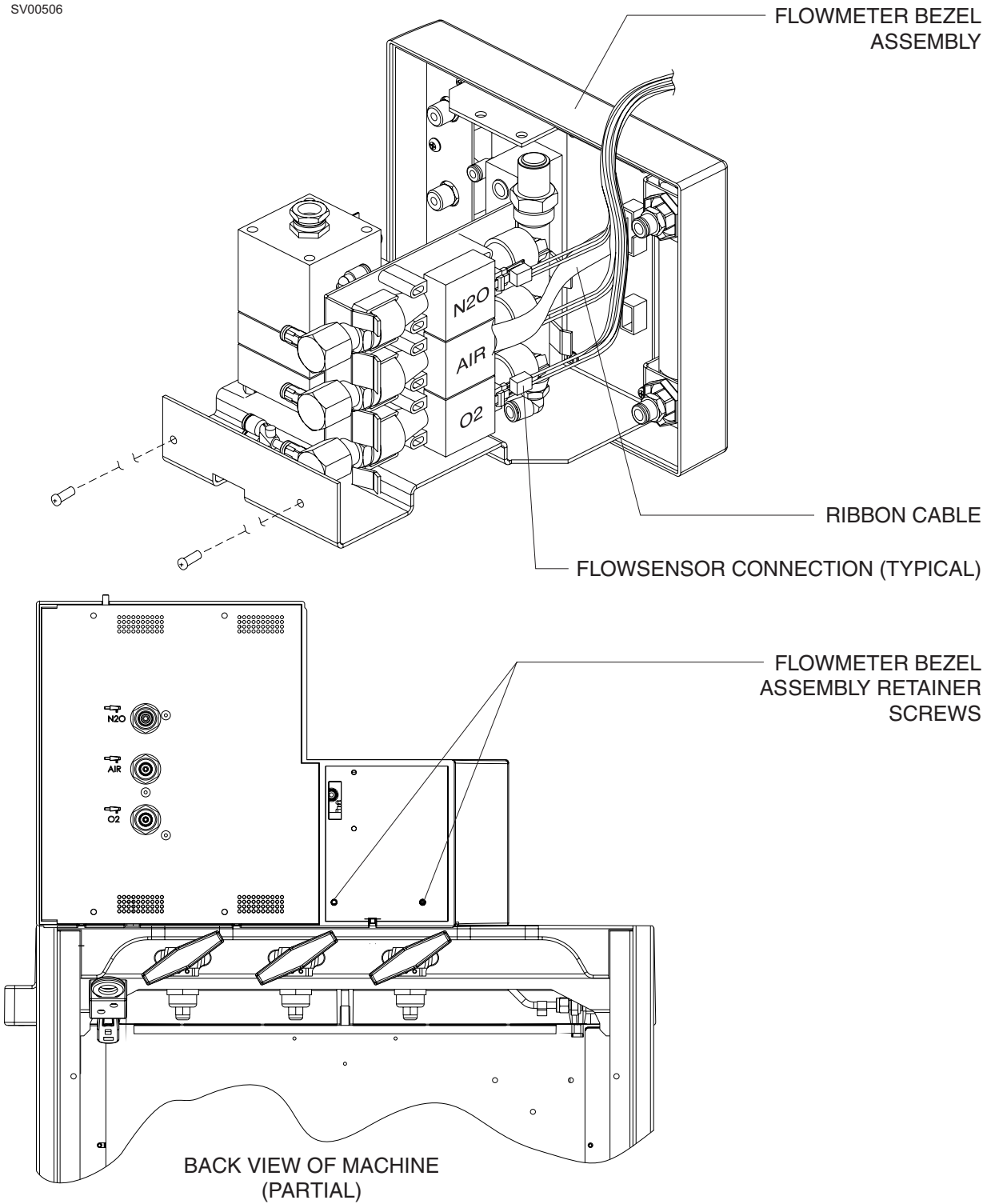

Figure 5-21. Flowmeter Bezel Assembly

5.14 Fresh Gas Flow Meter

Access to the fresh gas flow meter requires removal of the flow meter bezel assembly as described in a previous paragraph. [Figure 5-22](#) shows the tubing and mounting arrangement for the fresh gas flow tube. For clarity, other sub-assemblies are not shown in the illustration.

- 5.14.1 Set the main power switch to OFF and disconnect AC power from the machine.
- 5.14.2 Disconnect the pipeline and cylinder supplies.
- 5.14.3 Remove the screws securing the bezel assembly (refer to the Flow Meter Bezel Assembly instructions, Section [5.13](#)) and bring the assembly forward for access to the fresh gas flow meter.
- 5.14.4 Disconnect the tubing from the flow tube ports and remove the Luer fittings.
- 5.14.5 Remove the flow tube mounting nuts to release the flow tube.
- 5.14.6 Install the replacement flow tube with the mounting brackets and nuts supplied. Ensure that the float moves freely without sticking, and that the flow tube is oriented properly.
- 5.14.7 Reinstall the Luer fittings and reconnect the tubing.
- 5.14.8 Reinstall the flow meter bezel assembly in the machine (refer to the Flow Meter Bezel Assembly instructions, Section [5.13](#)).
- 5.14.9 Reconnect the pipeline supplies and restore power to the machine.
- 5.14.10 Perform the PMS procedure given in Section [7.0](#).

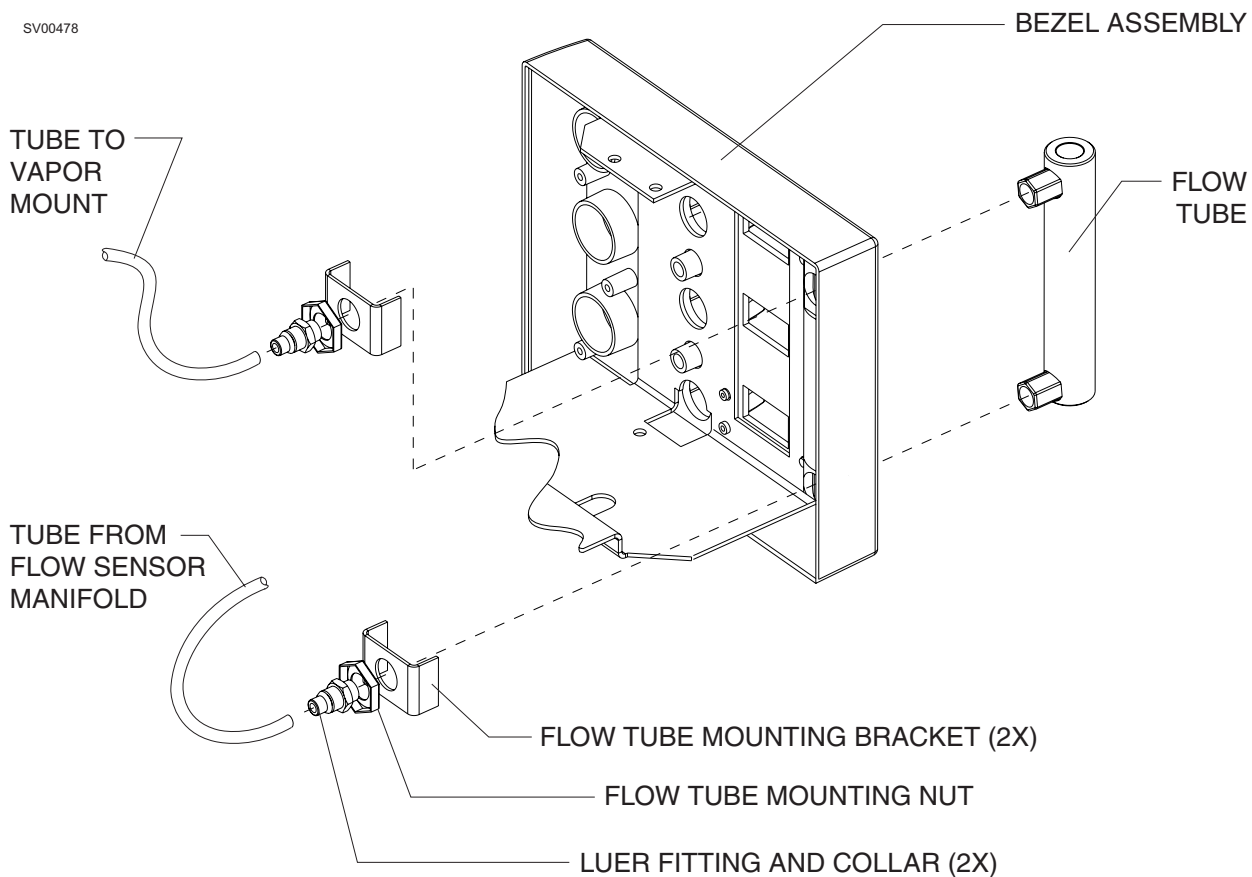
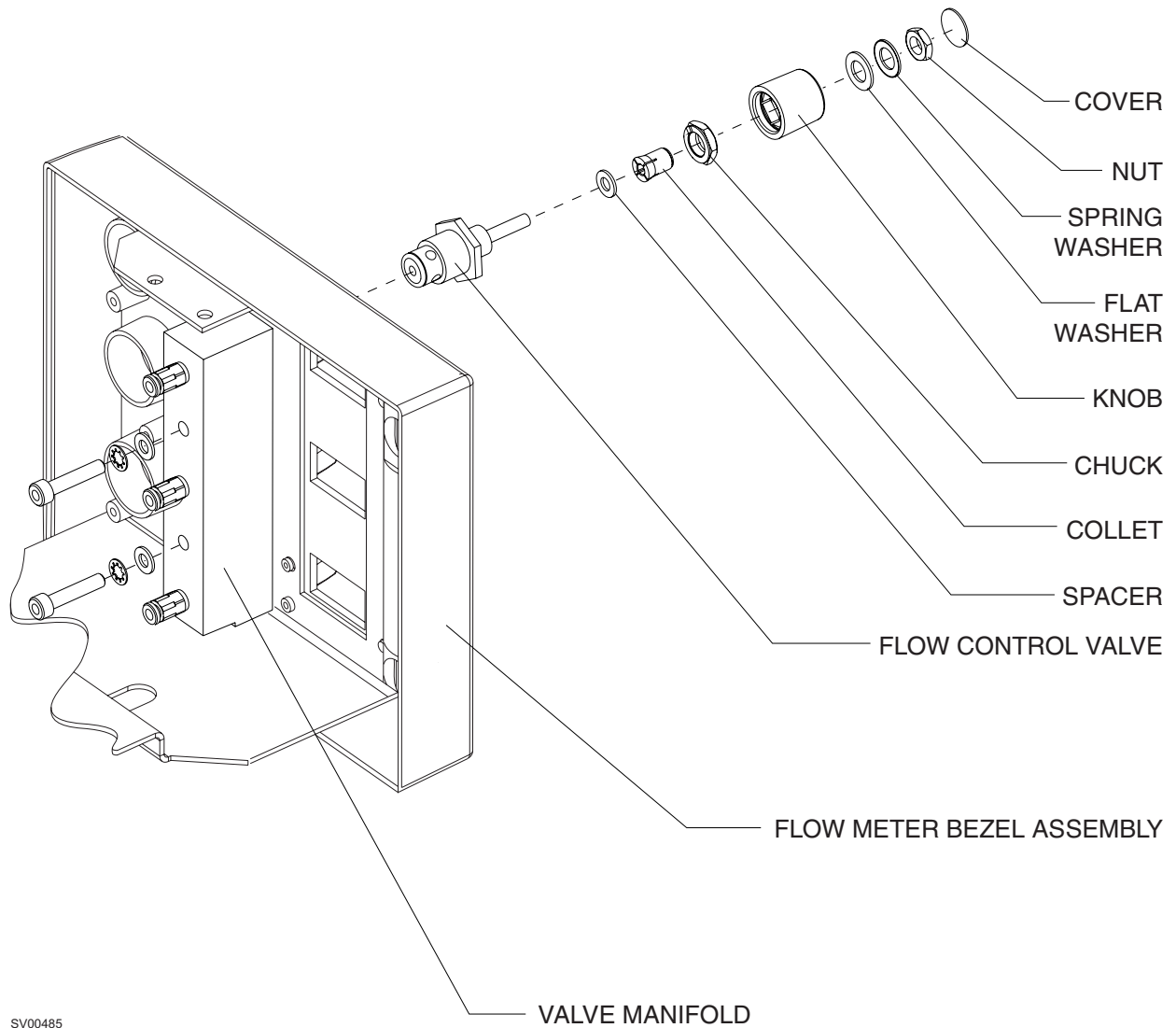

Figure 5-22. Fresh Gas Flow Meter

5.15 Flow Control Valves

Flow control valves can be replaced from the front panel while the flow meter bezel assembly is in place. [Figure 5-23](#) shows the hardware arrangement for a typical flow control valve. Should the valve manifold need to be replaced, its mounting arrangement is shown in the illustration. For clarity, other sub-assemblies are not shown in the illustration.

- 5.15.1 Set the main power switch to OFF and disconnect AC power from the machine.
 - 5.15.2 Disconnect the pipeline and cylinder supplies.
 - 5.15.3 Remove the cover from the knob of the valve to be replaced.
 - 5.15.4 Loosen the nut securing the knob to the valve, and pull the knob from the valve.
 - 5.15.5 Un-screw the flow control valve from the valve manifold.
 - 5.15.6 Install the replacement valve in the manifold.
- NOTE:** Use plastic jaw pliers (P/N 7910296) to hold the knob while tightening the nut in the next step.
- 5.15.7 Reinstall the knob and tighten the nut to secure the knob to the valve.
 - 5.15.8 Reinstall the cover on the knob.
 - 5.15.9 Reconnect the pipeline supplies and restore power to the machine.
 - 5.15.10 Set the main power switch to ON and ensure that the gas flow can be controlled over its entire range.
 - 5.15.11 Perform the PMS procedure given in Section [7.0](#).



SV00485

Figure 5-23. Flow Control Valves

5.16 Fresh Gas Flow Sensors and Filter Assembly

Access to the flow sensors and filter assembly requires removal of the flow meter bezel assembly as described in Section 5.13. Figure 5-24. shows the tubing and mounting arrangement for this sub-assembly. For clarity, other sub-assemblies are not shown in the illustration.

NOTE: The safety valve, filter, and flow sensors can be serviced without complete removal of this sub-assembly from the flow meter bezel assembly. The illustration shows an exploded view to indicate connections that would not otherwise be visible.

- 5.16.1 Set the main power switch to OFF and disconnect AC power from the machine.
- 5.16.2 Disconnect the pipeline and cylinder supplies.
- 5.16.3 Remove the screws securing the bezel assembly (refer to the Flow Meter Bezel Assembly instructions, Section 5.13) and bring the assembly forward for access to the flow sensor sub-assembly.
- 5.16.4 The filter is accessible by un-screwing the safety valve from the manifold.

The flow sensors and manifold are held in place by a spring clip arrangement.

The SORC bypass valve is secured to the flow sensor bracket by two screws and kep nuts as shown in the illustration.

- 5.16.5 Apply Loctite (#425 - Blue) to the adapter fitting on the end of the flowsensor, then install the replacement angle connector on the flowsensor hand tight.

CAUTION: While securing the plastic hex located on the flowsensor, tighten the angle connector to the flowsensor and align per original location.

- 5.16.6 Install the O-ring on the white manifold squarely by twisting the O-ring side to side until it is fully seated against the shoulder. Do not allow the O-ring to roll, it will not allow proper sealing once the flow valve is installed.
- 5.16.7 Place the flowmeter opening squarely over the O-ring and twist the flowmeter side to side until it is seated onto the manifold. Do not force the flowmeter over the O-ring or it will not seat properly.

- 5.16.8 Reinstall the flow meter bezel assembly in the machine (refer to the Flow Meter Bezel Assembly instructions, Section 5.13).
- 5.16.9 Reconnect the pipeline supplies and restore power to the machine.
- 5.16.10 Perform the PMS procedure including calibrations, given in Section 7.0.

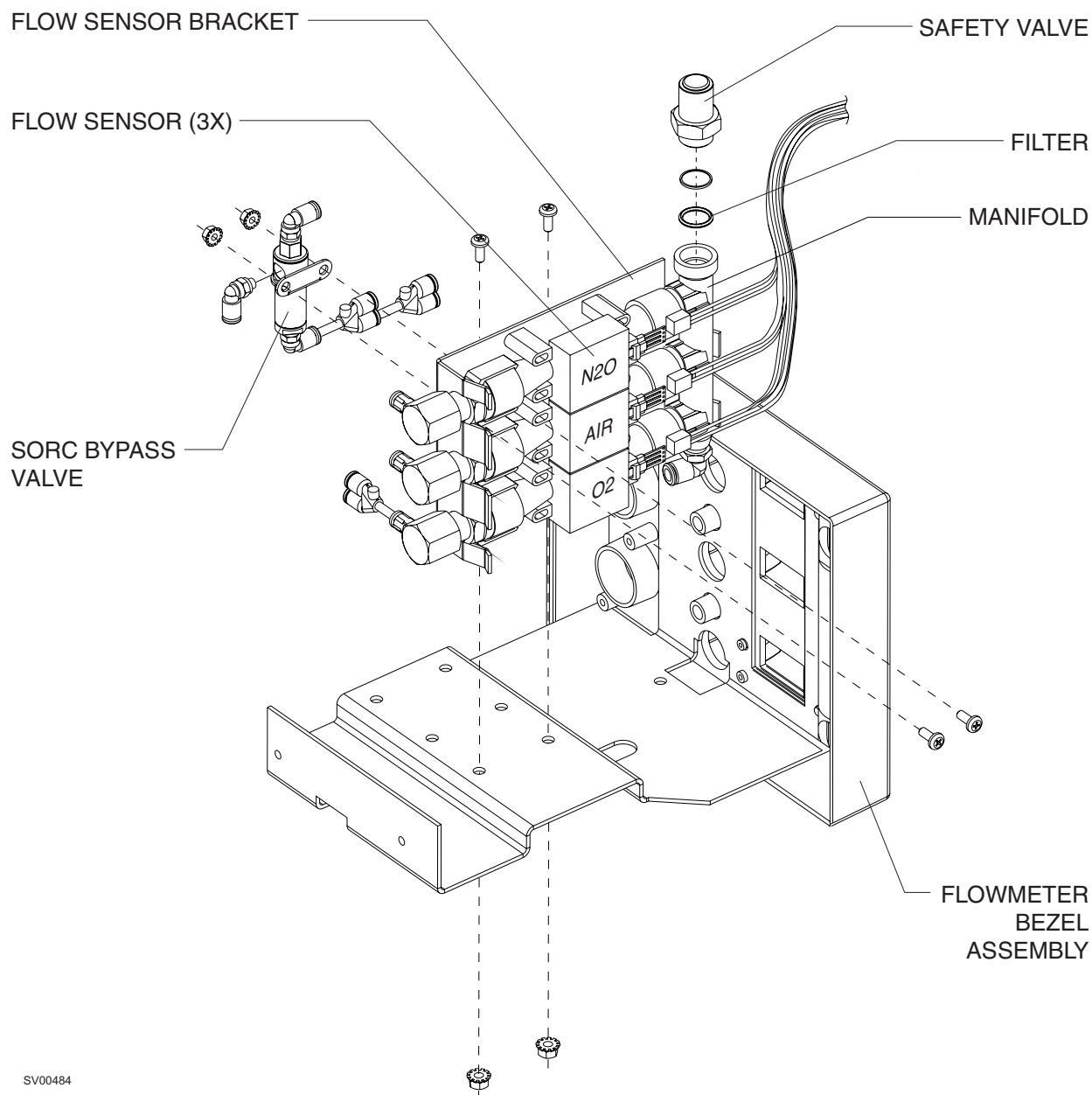

SV00484

Figure 5-24. Fresh Gas Flow Sensors and Filter Assembly

5.17 Pipeline Pressure Gauges

Access to the pipeline pressure gauges requires removal of the flow meter bezel assembly as described in Section 5.13. Figure 5-25. shows the tubing and mounting arrangement for the gauges. For clarity, other sub-assemblies are not shown in the illustration.

- 5.17.1 Set the main power switch to OFF and disconnect AC power from the machine.
- 5.17.2 Disconnect the pipeline and cylinder supplies.
- 5.17.3 Remove the screws securing the bezel assembly (refer to the Flow Meter Bezel Assembly instructions, Section 5.13 given previously in this section) and bring the assembly forward for access to the pipeline pressure gauges.
- 5.17.4 Disconnect the tubing from the fitting on the gauge to be replaced.
- 5.17.5 Remove the retainer plate screws, and separate the retainer plate with the gauges from the bezel.
- 5.17.6 Un-thread the straight fitting from the back of the gauge to be replaced.
- 5.17.7 Remove the gauge mounting nut, and remove the gauge from the retainer plate.
- 5.17.8 Install the replacement gauge in the retainer plate - make sure it is oriented properly when tightening the gauge mounting nut.
- 5.17.9 Reinstall the straight fitting in the back of the gauge.
- 5.17.10 Reinstall the gauge retainer plate in the bezel.
- 5.17.11 Reconnect the tubing that was previously removed.
- 5.17.12 Reinstall the flow meter bezel assembly in the machine (refer to the Flow Meter Bezel Assembly instructions, Section 5.13).
- 5.17.13 Reconnect the pipeline supplies and restore power to the machine.
- 5.17.14 Perform the PMS procedure given in Section 7.0.

SV88012

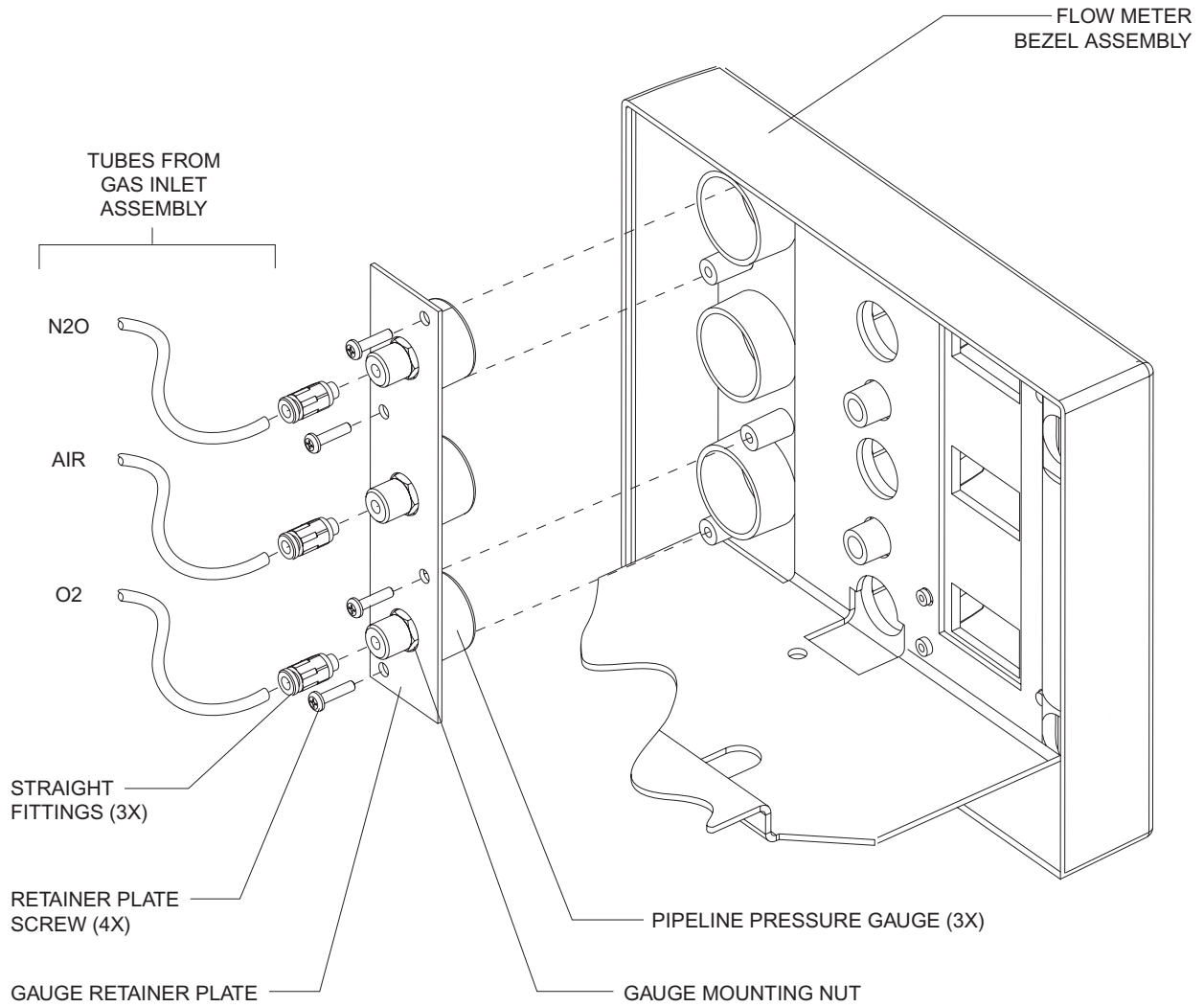
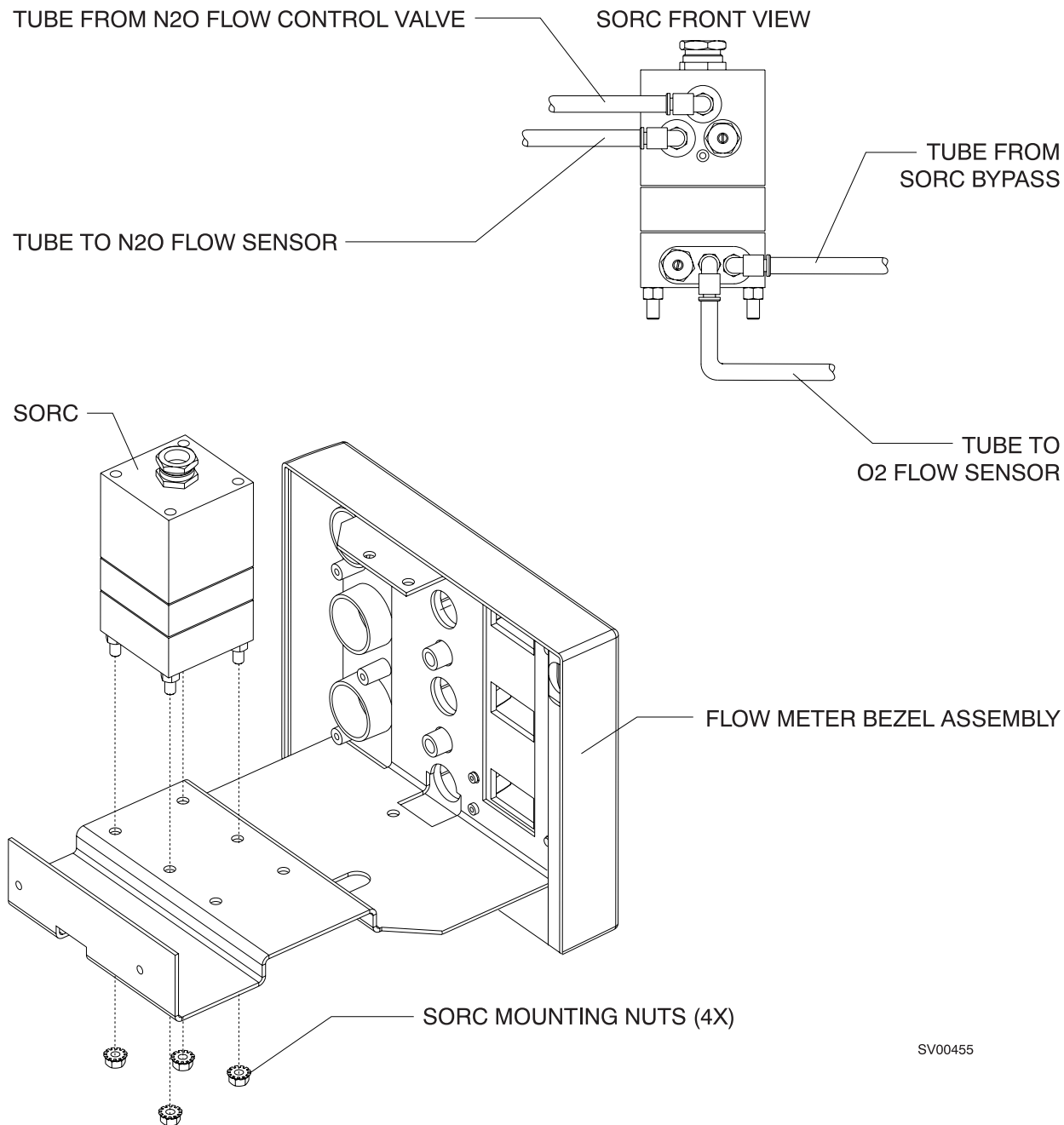

Figure 5-25. Pipeline Pressure Gauges

5.18 SORC (Sensitive Oxygen Ratio Controller)

Access to the SORC requires removal of the flow meter bezel assembly as described in Section 5.13. Figure 5-26 shows the tubing and mounting arrangement for the SORC. For clarity, other sub-assemblies are not shown in the illustration.

- 5.18.1 Set the main power switch to OFF and disconnect AC power from the machine.
- 5.18.2 Disconnect the pipeline and cylinder supplies.
- 5.18.3 Remove the screws securing the bezel assembly (refer to the Flow Meter Bezel Assembly instructions, Section 5.13) and bring the assembly forward for access to the SORC.
- 5.18.4 Disconnect the tubing from the SORC where shown in Figure 5-26. Mark these tubes so they can be reattached to the replacement SORC in the same manner.
- 5.18.5 Remove the four SORC mounting nuts and remove the SORC from the flow meter bezel assembly.
- 5.18.6 Install the replacement SORC with the four mounting nuts that were previously removed.
- 5.18.7 Re-connect the O₂ and N₂O tubing to the SORC in the same manner as the original.
- 5.18.8 Reinstall the flow meter bezel assembly in the machine (refer to the Flow Meter Bezel Assembly instructions, Section 5.13).
- 5.18.9 Reconnect the pipeline supplies and restore power to the machine.
- 5.18.10 Perform the PMS procedure given in Section 7.0.



SV00455

Figure 5-26. SORC

5.19 Fresh Gas Display PCB

Access to the fresh gas display PCB requires removal of the flow meter bezel assembly as described in Section 5.13. Figure 5-27. shows the cable connections and PCB mounting details. For clarity, other sub-assemblies are not shown in the illustration.

- 5.19.1 Set the main power switch to OFF and disconnect AC power from the machine.
- 5.19.2 Disconnect the pipeline and cylinder supplies.
- 5.19.3 Remove the screws securing the bezel assembly (refer to the Flow Meter Bezel Assembly instructions, Section 5.13) and bring the assembly forward.
- 5.19.4 Remove the two screws securing the flow sensor sub-assembly to the bezel assembly, and move the sub-assembly aside for access to the fresh gas display PCB. (Refer to the Fresh Gas Flow Sensors and Filter Assembly instructions given in Section 5.16.)
- 5.19.5 Disconnect the cables from the fresh gas display PCB where shown in Figure 5-27. .
- 5.19.6 Remove the PCB mounting screws and lock washers, and remove the PCB.
- 5.19.7 Install the replacement fresh gas PCB, with the insulator in place using the hardware that was previously removed.
- 5.19.8 Reconnect the cables to the PCB.
- 5.19.9 Reinstall the flow sensor sub-assembly.
- 5.19.10 Reinstall the flow meter bezel assembly in the machine (refer to the Flow Meter Bezel Assembly instructions, Section 5.13).
- 5.19.11 Reconnect the pipeline supplies and restore power to the machine.
- 5.19.12 Perform the PMS procedure given in Section 7.0.

SV00483

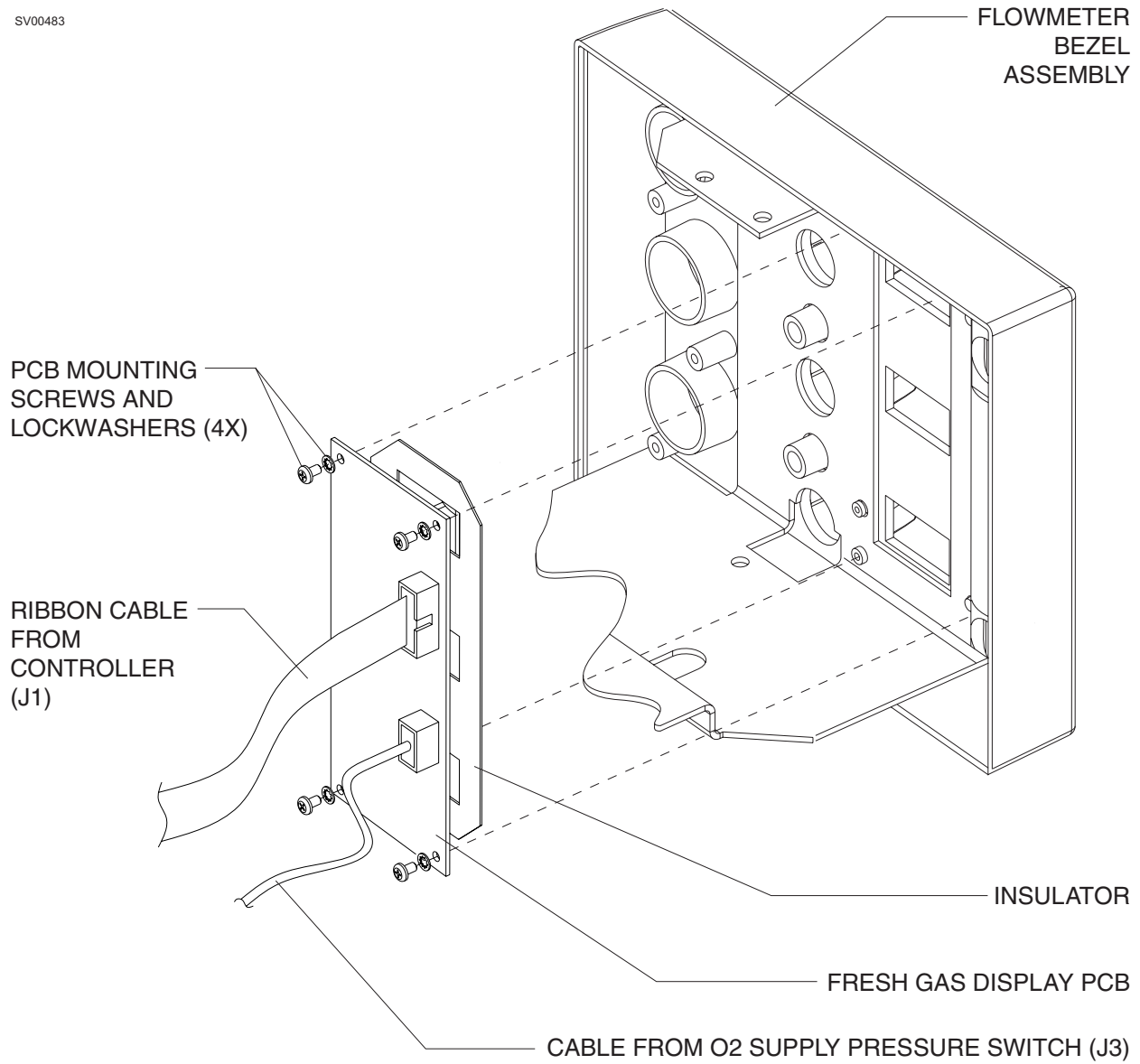

Figure 5-27. Fresh Gas Display PCB

5.20 Monitor Bezel Assembly

The monitor bezel assembly comprises the keypad, flat panel display, rotary switch, and LED lamp PCB assembly. Access to the bezel assembly mounting screws is through the ventilator compartment as shown in [Figure 5-28](#).

NOTE: Replacement keypads do not include key pad inserts. Therefore, removal of the original key pad insert for later reuse is necessary. Refer to [Figure 5-28](#) for key pad insert location.

5.20.1 Set the main power switch to OFF and disconnect AC power from the machine.

5.20.2 Swing open the ventilator door.

5.20.3 While supporting the bezel assembly, remove the two screws securing the left side of the bezel.

CAUTION: Do Not pull the bezel outward, as this will break the locking tabs at the right side of the bezel.

5.20.4 Slide the bezel to the right to release its locking tabs from the machine. See [Figure 5-28](#).

NOTE: Verify that bezel locking tabs are clear of the machine before pulling the bezel away from the machine.

5.20.5 Disconnect the large ribbon cable from the keypad connector, and the smaller ribbon cable from the display panel.

5.20.6 Disconnect the ground wire.

Refer to the parts list in [Section 9.0](#) for identification of individual components.

5.20.7 Reconnect the ground wire and the two ribbon cables to the replacement assembly.

5.20.8 Carefully fold the cables behind the bezel assembly as you bring it into position on the machine. Hold the bezel against the machine and slide it to the left to engage the locking tabs in the slots in the machine housing.

5.20.9 While supporting the bezel assembly, reinstall the two screws at the back of the bezel on the left side.

5.20.10 Close the ventilator door.

5.20.11 Restore power to the machine and verify all of the keypad and display functions.

5.20.12 Perform the PMS procedure given in [Section 7.0](#).

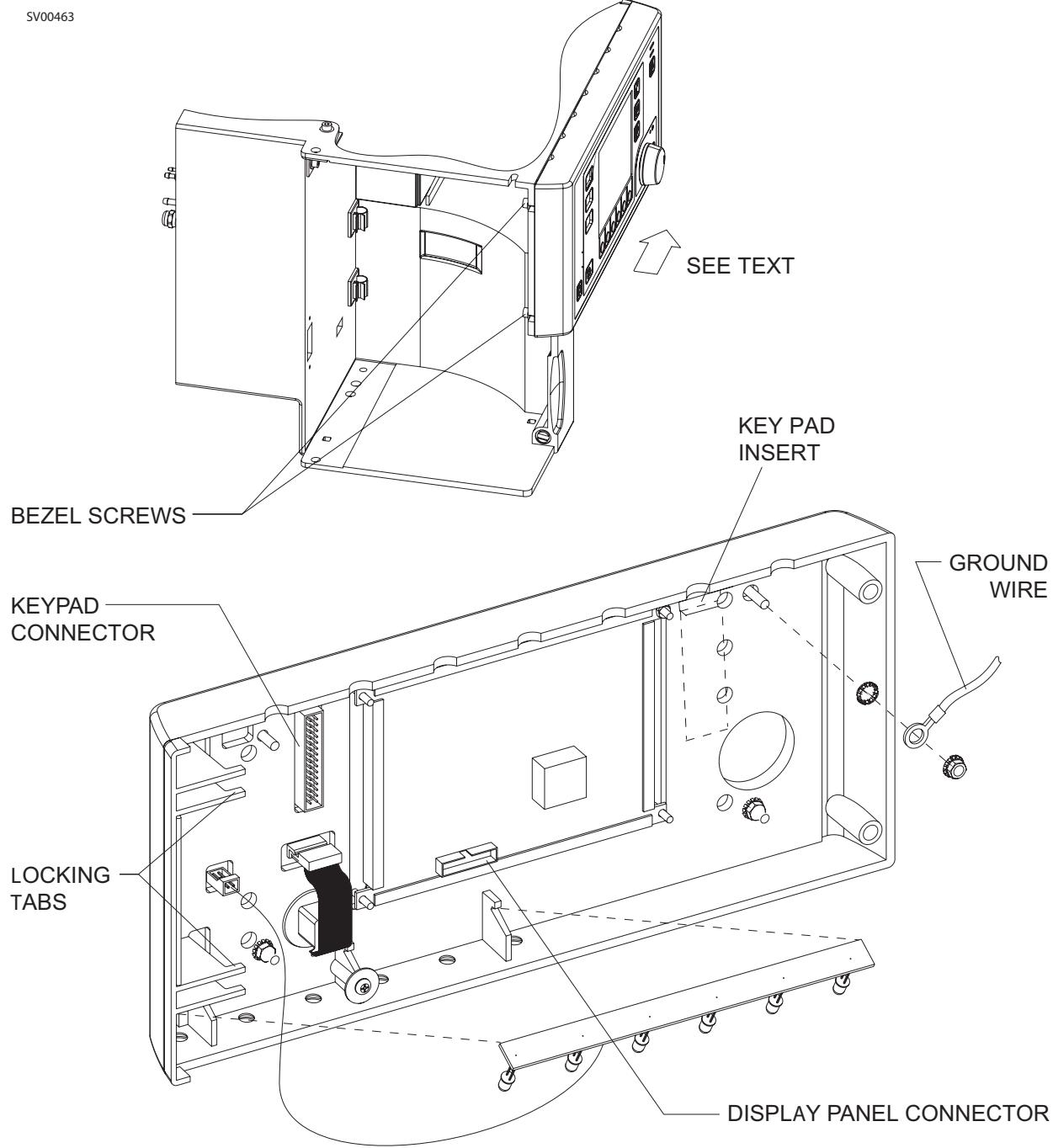

Figure 5-28. Monitor Bezel Assembly

5.21 Spirolog Sensor and Cable

- 5.21.1 Set machine power switch to OFF and disconnect AC power from the machine.
- 5.21.2 Remove the expiratory hose terminal from the breathing system, and slide the Spirolog sensor out of the breathing system.
- 5.21.3 Disconnect the cable from the sensor by squeezing the connector at the points opposite the latch while pulling the connector away from the sensor.
- 5.21.4 Remove the back panel from the controller housing, and disconnect the Spirolog cable from J18 on the controller PCB.
- 5.21.5 Loosen the nut on the strain relief bushing at the interface panel. Remove the strain relief bushing from the panel while supporting the rear nut.
- 5.21.6 Install the replacement Spirolog strain relief bushing into the interface panel, and tighten the nut.
- 5.21.7 Connect the replacement Spirolog cable to J18 on the controller PCB.
- 5.21.8 Route the cable from the machine to the breathing system in the same manner as the original.
- 5.21.9 Connect the outboard end of the Spirolog cable to the flow sensor. Note that the sensor and connector are keyed.
- 5.21.10 Reinstall the back panel on the controller housing, and restore AC power to the machine.
- 5.21.11 Perform the PMS procedure given in Section [7.0](#).

[RETURN TO THIS MANUAL'S TABLE OF CONTENTS](#)
[RETURN TO CD-ROM TABLE OF CONTENTS](#)

6.0 ADJUSTMENT AND CALIBRATION PROCEDURES

6.1 Cylinder Pressure Regulator Adjustment

6.1.1 Set the System Power switch to OFF.

NOTE: Minimum cylinder pressures for this adjustment shall be:
N₂O: 700 psi; O₂ or Air: 1000 psi.

NOTE: Figure 6-1. shows test connections for the O₂ regulator adjustment. If you are adjusting the N₂O regulator, connect the test gauge in series with the N₂O pipeline hose.

6.1.2 Connect test pressure gauge (P/N 4114807) between machine's pipeline inlet connector and the pipeline supply hose.

6.1.3 Open the cylinder valves and set the System Power switch to ON.

6.1.4 Set the oxygen flow to 4 liters per min. (If you are adjusting the N₂O regulator, also set the nitrous oxide flow to 4 liters per minute.)

6.1.5 Depress the push button on the test device.

6.1.6 Release the push button. After the pressure decay stabilizes, the gauge should indicate 32-40 psi.

6.1.7 Remove the acorn nut from the regulator to expose the adjusting screw. For N₂O, turn the screw until the test gauge indicates 35 psi. (50 psi for CSA machines). For O₂ and Air, use the compensated regulator output setting based on the cylinder pressure given in the following table.

CAUTION: Based on information supplied by the cylinder regulator manufacturer, when the regulator is used for O₂ or Air, its output pressure will decrease 0.5 psi for every 100 psi increase in cylinder pressure above 1000 psi. Currently, these pressure regulators are calibrated at 35 psi with a cylinder supply of 1000 psi. If a 2000 psi cylinder is then installed, the regulator output will be 42 psi. This change in output must be compensated for to provide accurate performance throughout the cylinder's working range.

SV00465

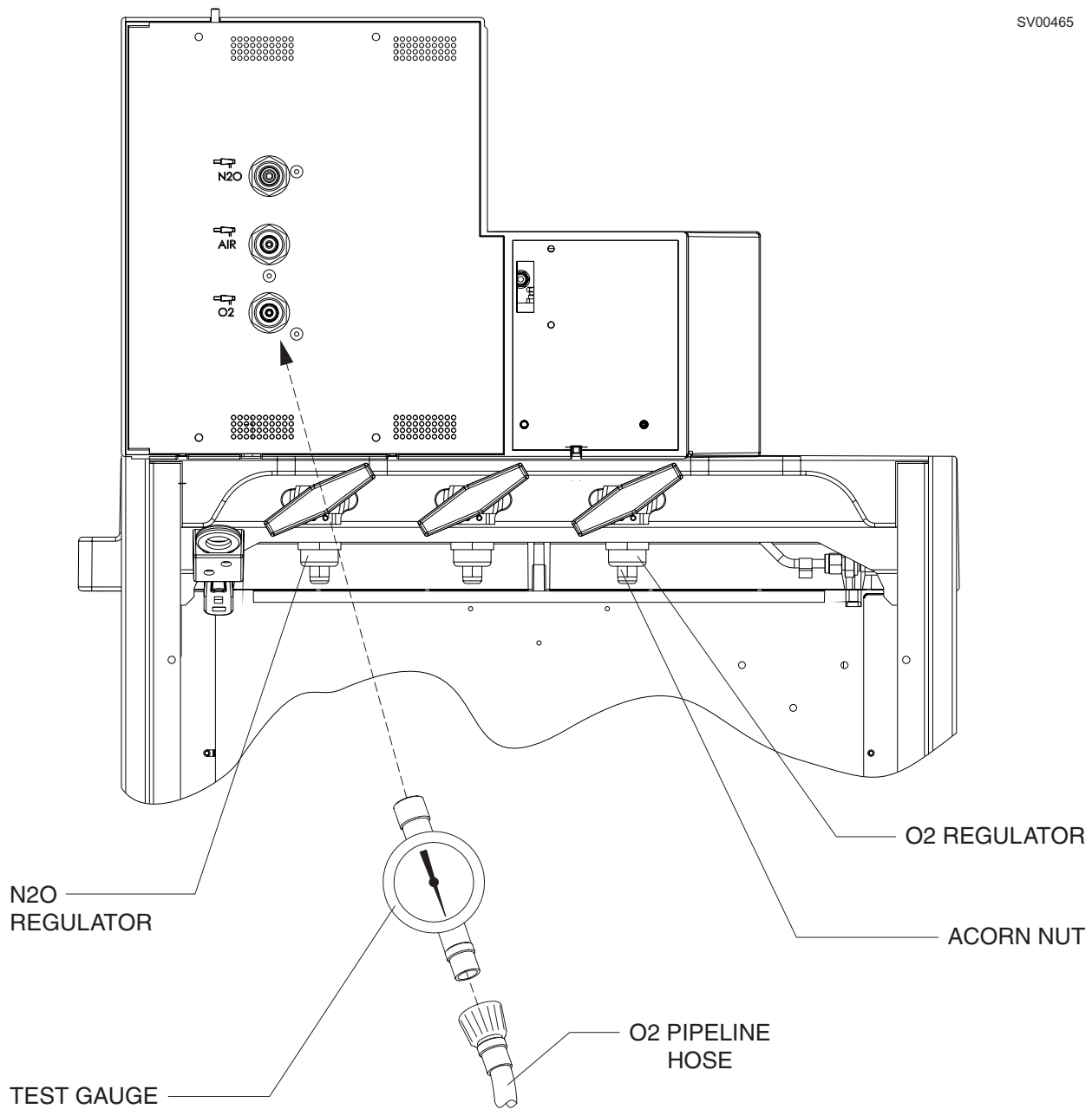

Figure 6-1. Cylinder Pressure Regulator Adjustment: O2 Connection Illustrated

NOTE: Cylinder pressure compensation for the N₂O regulator is not required.

Cylinder Pressure (psi)	Compensated Regulator output tolerances (-4/+2)
2000	27 - 33 (*30 - 36)
1800	28 - 34 (*31 - 37)
1600	29 - 35 (*32 - 38)
1400	30 - 36 (*33 - 39)
1200	31 - 37 (*34 - 40)
1000	32 - 38 (*35 - 41)

* Canada settings

- 6.1.8 Verify the adjusted regulator maintains its compensated output tolerance.
- 6.1.9 If the O₂ cylinder regulator output was adjusted, perform the following test:
- 6.1.10 Set the ventilator to Volume Mode ventilation.
- 6.1.11 Set the Auxiliary O₂ and Fresh Gas O₂ flows to 10 L/min.
- 6.1.12 Press the O₂ Flush and verify the Lo O₂ Supply alarm is not active. If the alarm is active refer to Section 6.3: Oxygen Supply Pressure Alarm Switch Adjustment.
- 6.1.13 Reinstall the acorn nut on the regulator.
- 6.1.14 Close the cylinder valves and allow pressure to drain from the system.
- 6.1.15 Close all of the flow control valves and set the System Power switch to OFF.
- 6.1.16 Disconnect the test gauge.
- 6.1.17 Connect the pipeline hoses.
- 6.1.18 Perform the PMS Procedure given in Section 7.0.

6.2 Gas Inlet Regulator Output Adjustment

O2 Inlet Regulator:

- 6.2.1 Bleed all cylinder and pipeline pressures. Disconnect all cylinders and pipeline hoses.
- 6.2.2 Remove the rear cover supporting the gas inlet assembly.
- 6.2.3 Remove the pneumatic hose from the O2 outlet of the gas inlet block and interconnect a digital manometer as shown in [Figure 6-2](#).

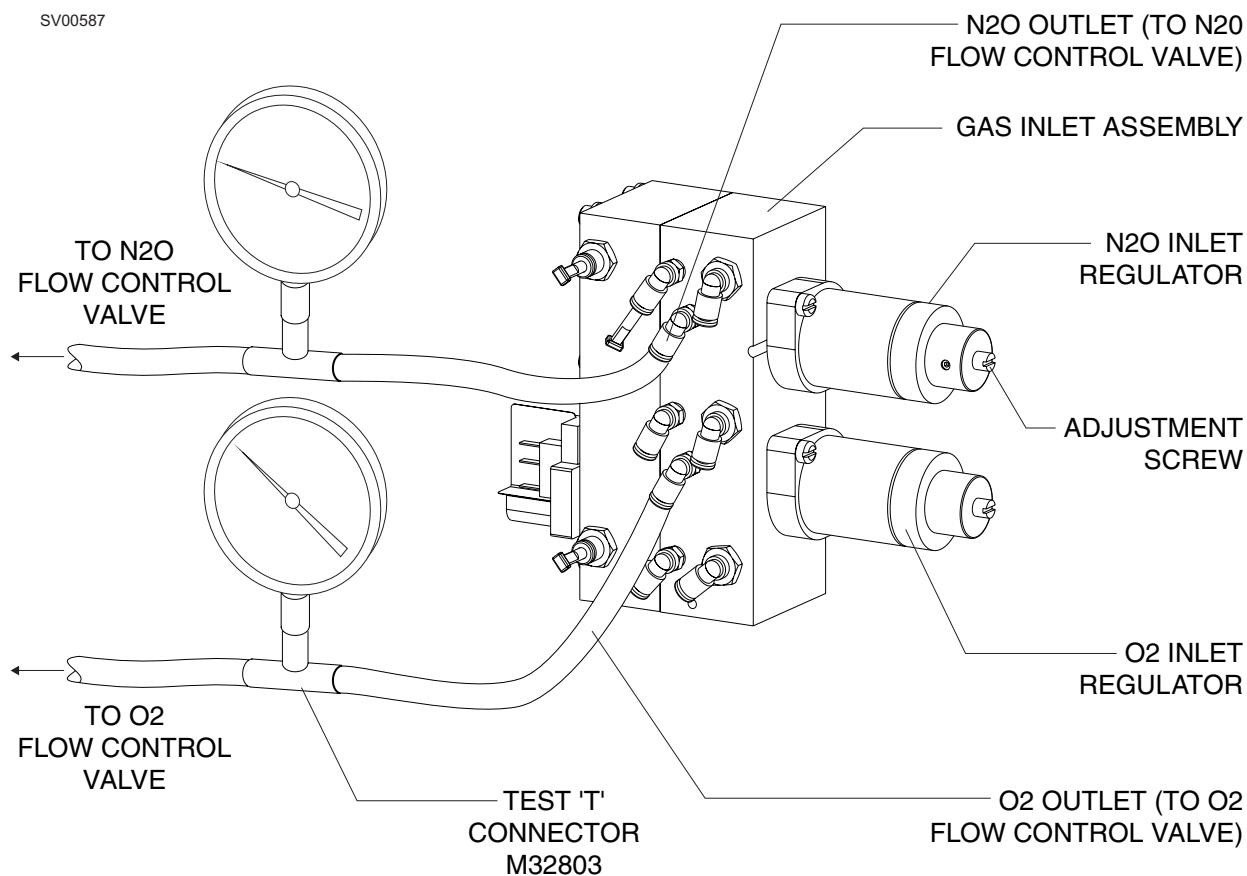

Figure 6-2. Setting Inlet Regulators

- 6.2.4 Reconnect the O₂ pipeline supply hose to the O₂ pipeline inlet connector and pressurize the O₂ supply.
- 6.2.5 Set the O₂ flow to 4 L/min.
- 6.2.6 After the digital manometer stabilizes, adjust the O₂ regulator output pressure to 30 psi.
- 6.2.7 Deplete O₂ pressure from the pipeline supply.
- 6.2.8 Close the flow control valve and disconnect the O₂ pipeline hose from the inlet.
- 6.2.9 Remove test equipment and reconnect the O₂ pneumatic hose leading from the O₂ flow control valve to the O₂ connector on the inlet block.
- 6.2.10 Reinstall rear cover and perform the PMS Procedure given in Section 7.0.

N₂O Inlet Regulator:

- 6.2.11 Disconnect the N₂O pneumatic hose from the outlet connector on the gas inlet block that connects to the N₂O flow control valve.
- 6.2.12 Interconnect a digital manometer between the N₂O outlet connector and the hose removed in the previous step. See [Figure 6-2](#).
- 6.2.13 Reconnect the N₂O pipeline hose to the inlet connector and activate the N₂O supply.
- 6.2.14 Set the O₂ and N₂O flows to 4 L/min. After the digital manometer stabilizes, adjust the N₂O regulator output pressure to 30 psi.
- 6.2.15 Deplete the O₂ and N₂O pipeline pressures.
- 6.2.16 Close the O₂ and N₂O flow control valves, and disconnect both pipeline hoses from the inlets.
- 6.2.17 Remove the test equipment and reconnect the N₂O hose from the flow control valve to the N₂O outlet on the inlet block.
- 6.2.18 Reinstall the rear cover and perform the PMS procedure given in Section 7.0.

6.3 Oxygen Supply Pressure Alarm Switch Adjustment

- 6.3.1 Disconnect all pipeline hoses and set the System Power switch to ON.
 - 6.3.2 Close all cylinder valves except the O₂ valve.
 - 6.3.3 Set the oxygen flow to 5 liters per min.
 - 6.3.4 Open the other gas flow control valves to drain pressure from the system.
 - 6.3.5 Close the O₂ cylinder valve, and close the flow control valves. Press the O₂ Flush valve to drain oxygen pressure from the system.
 - 6.3.6 Set the System Power switch to OFF.
 - 6.3.7 Remove the rear cover supporting the gas inlet assembly.
 - 6.3.8 Connect test pressure gauge (P/N 4114807) between machine's oxygen pipeline inlet connector and the oxygen pipeline supply hose.
 - 6.3.9 Open the O₂ cylinder valve and set the System Power switch to ON.
 - 6.3.10 Set the oxygen flow to 200 mL per min.
 - 6.3.11 Close the oxygen cylinder valve.
 - 6.3.12 As the pressure drops, the O₂ SUPPLY alarm should activate when the pressure is between 16 and 24 psi as shown on the test gauge.
 - 6.3.13 If the alarm activates when the pressure is below 16 psi or above 24 psi, turn the adjustment set screw (see [Figure 6-3.](#)); repeat the test and adjust as necessary to bring the set point into the correct range.
- NOTE:** Turn the screw counter-clockwise to decrease the alarm activation.
- 6.3.14 Set the System Power switch to OFF.
 - 6.3.15 Disconnect the test gauge.
 - 6.3.16 Reinstall the rear cover and gas inlet assembly.
 - 6.3.17 Connect the pipeline hoses.
 - 6.3.18 Perform the PMS Procedure given in Section [7.0](#).

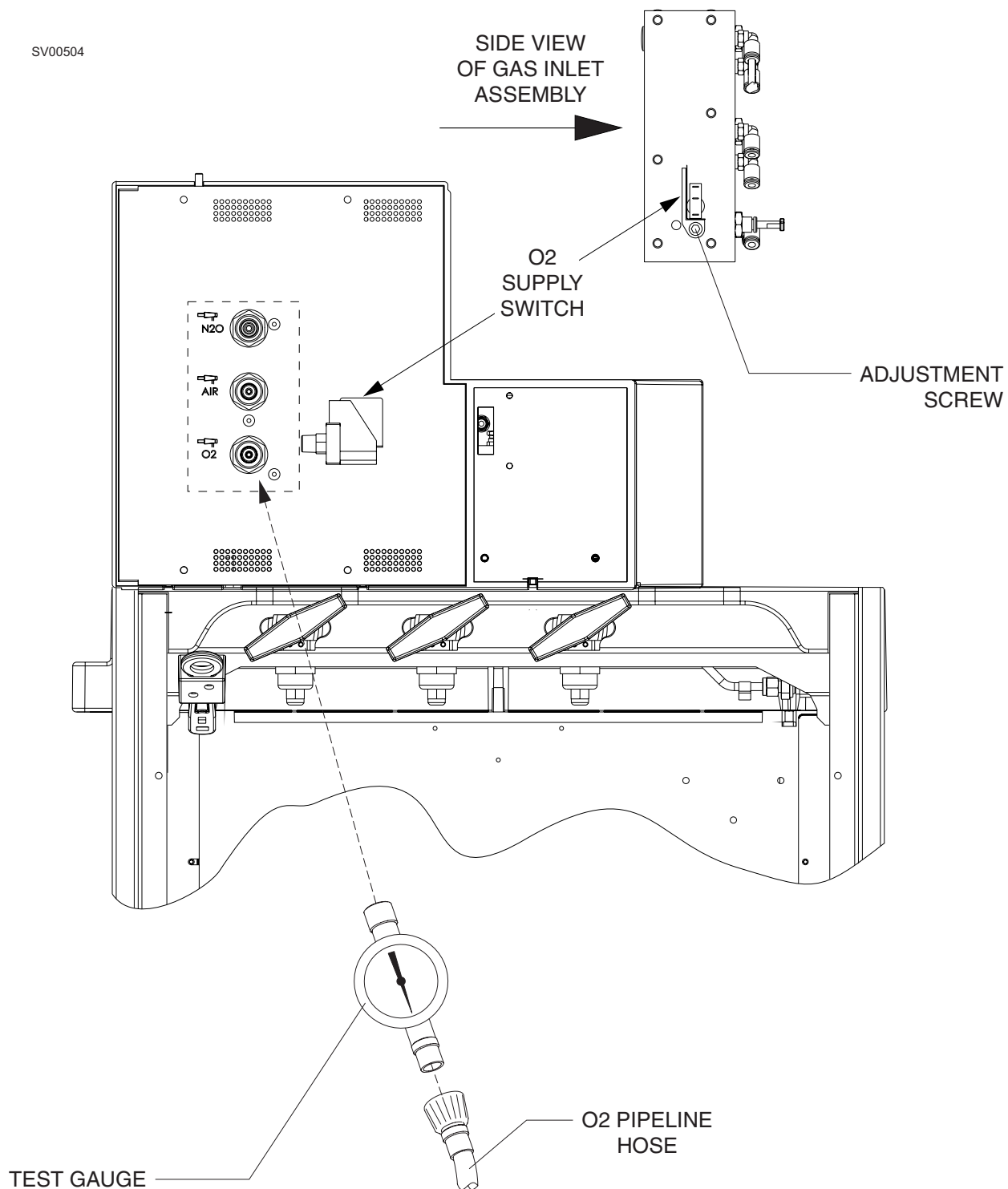

Figure 6-3. Oxygen Supply Pressure Alarm Switch Adjustment

6.4 Sensitive Oxygen Ratio Controller (SORC) Adjustment

- 6.4.1 Set the System Power switch to OFF.
- 6.4.2 Remove the two screws at the back of the machine securing the flow meter bezel assembly. Carefully pull the assembly out of the machine for access to the SORC.
- 6.4.3 Connect a test pressure gauge to the O₂ port on the SORC shown in [Figure 6-4](#).
- 6.4.4 Connect an oxygen analyzer to the fresh gas outlet.
- 6.4.5 Connect the pipeline supplies.
- 6.4.6 Set the System Power switch to ON.

Setting O₂ Control Pressure:

- 6.4.7 Set the oxygen flow to 200 mL/min.
- 6.4.8 The test pressure gauge should read 25 ± 1 cmH₂O. If needed, turn the O₂ control pressure adjustment screw until the test gauge reads 25 ± 1 mbar. Apply a small amount of thread sealant to the screw head.

Adjusting the Operating Point:

- 6.4.9 Fully open the N₂O flow control valve.
- 6.4.10 Set the oxygen flow to 200 mL/min.
- 6.4.11 The N₂O flow should be 50 ± 30 mL/min. Make the following adjustment if needed:

Loosen the lock nut on top of the SORC.

Turn the operating point adjustment counter-clockwise to decrease the N₂O flow, or clockwise to increase the N₂O flow until it is at 50 ± 30 mL/min.

- 6.4.12 Tighten the lock nut and verify the N₂O flow is 50 ± 30 mL/min. Apply a small amount of thread sealant where the lock nut meets the threads of the adjustment point.

Adjusting the O₂/N₂O Ratio:

- 6.4.13 With the N₂O flow control valve fully open, set the oxygen flow to 1 L/min.

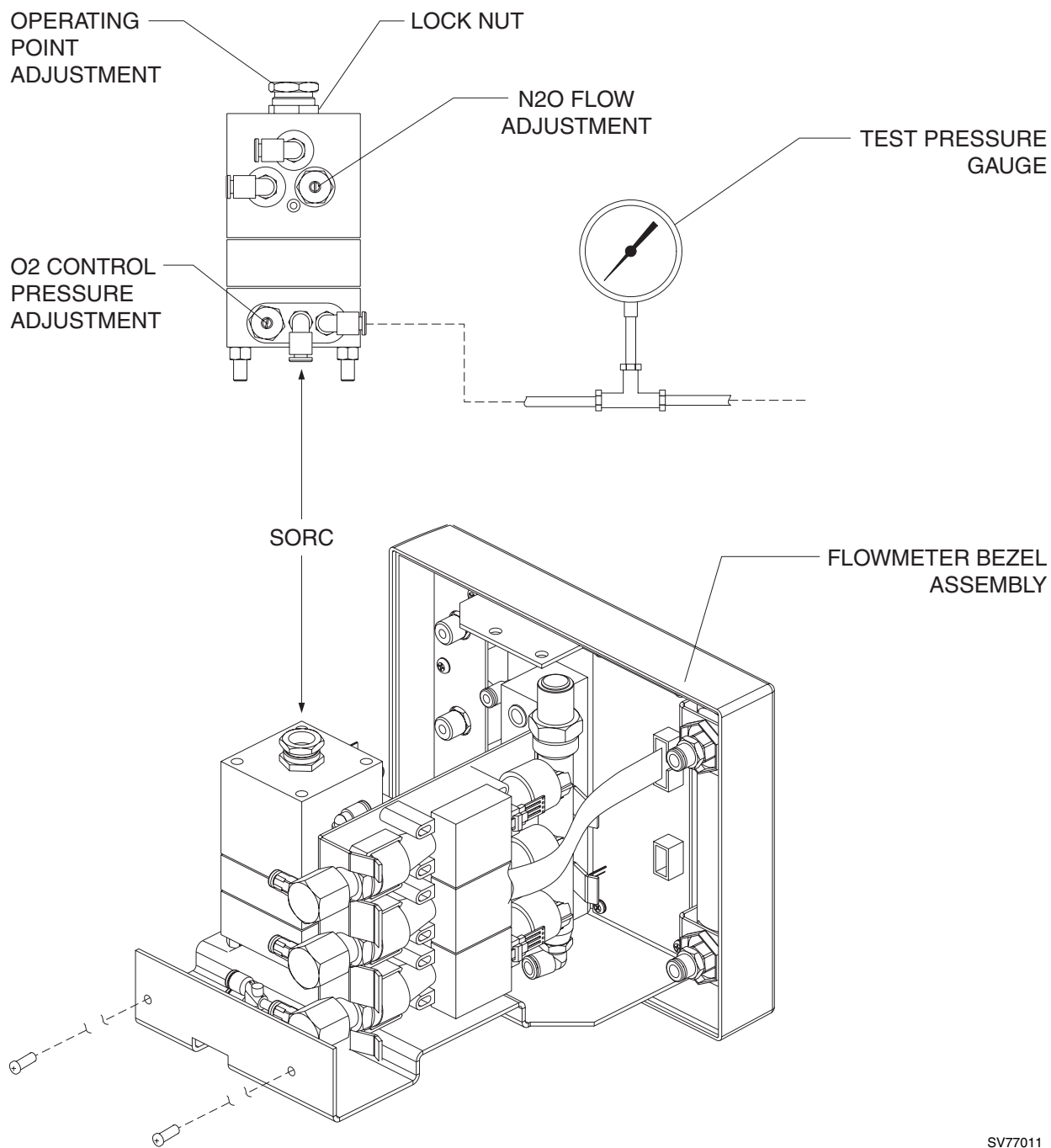

SV77011

Figure 6-4. Sensitive Oxygen Ratio Controller Adjustment

- 6.4.14 The N₂O flow should be 3 ± 0.3 mL/min, resulting in an O₂ concentration of 25 ± 3 vol. % O₂ at the fresh gas outlet.

If needed, turn the N₂O flow adjustment screw until the flow is 3 ± 0.3 mL/min, resulting in an O₂ concentration of 25 ± 3 vol. % O₂ at the fresh gas outlet. Apply a small amount of thread sealant on the adjustment screw.

O₂ Concentration Test:

- 6.4.15 Verify O₂ concentration at the fresh gas outlet, with the O₂ flow settings in the following table:

O ₂ Flow	N ₂ O Flow Control Valve	O ₂ Concentration
0.5 ± 0.05 L/min.	Fully Open	23 - 33
1.0 ± 0.1 L/min.		23 - 28
3.0 ± 0.2 L/min.		23 - 33

Flow Test:

- 6.4.16 Fully open the N₂O flow control valve.
- 6.4.17 Slowly open the O₂ flow control valve.
- 6.4.18 As the O₂ flow increases, the N₂O flow should also increase, to over 10 L/min. at the maximum.
- 6.4.19 Slowly close the O₂ flow control valve. The N₂O flow should decrease proportionally.
- 6.4.20 Close the flow control valves and remove all test equipment.
- 6.4.21 Set the System Power switch to OFF, and reinstall the flow meter bezel assembly in the machine.
- 6.4.22 Perform the PMS procedure given in Section [7.0](#).

6.5 Oxygen Sensor Calibration

- 6.5.1 Set the main power switch to ON.
- 6.5.2 Access the main service screen (ref. Section 4).
- 6.5.3 Scroll to Calibration and select O2 to bring up the O2 Zero calibration screen. See [Figure 6-5](#).

Zero Calibration:

- 6.5.3.1 Remove the oxygen sensor capsule from its housing and allow several minutes for the displayed offset readings to stabilize.

NOTE: The difference between the Cell A and Cell B readings should be no greater than 8.

- 6.5.3.2 Press the Store Zero soft key to store the current values as the new zero calibration.
- 6.5.3.3 Reinstall the sensor capsule in its housing.

21% Calibration:

- 6.5.3.4 Expose the sensor to ambient air only (away from any open part of the breathing system) and allow it to stabilize for several minutes.
- 6.5.3.5 Press the  key to return to the standby screen.
- 6.5.3.6 Press the Calibrate O2 Sensor softkey. An instruction window replaces the softkey labels.
- 6.5.3.7 Press the rotary knob to start the 21% O2 calibration. During calibration the 'Calibrate O2 Sensor' softkey shall illuminate. Following calibration the screen returns to normal.

NOTE: If an "O2 Sensor Calibration Failed" message appears, refer to the oxygen monitoring section of the Fabius GS Operator's Instruction Manual for further information.

- 6.5.3.8 Reinstall the O2 sensor assembly in the inspiratory valve dome.

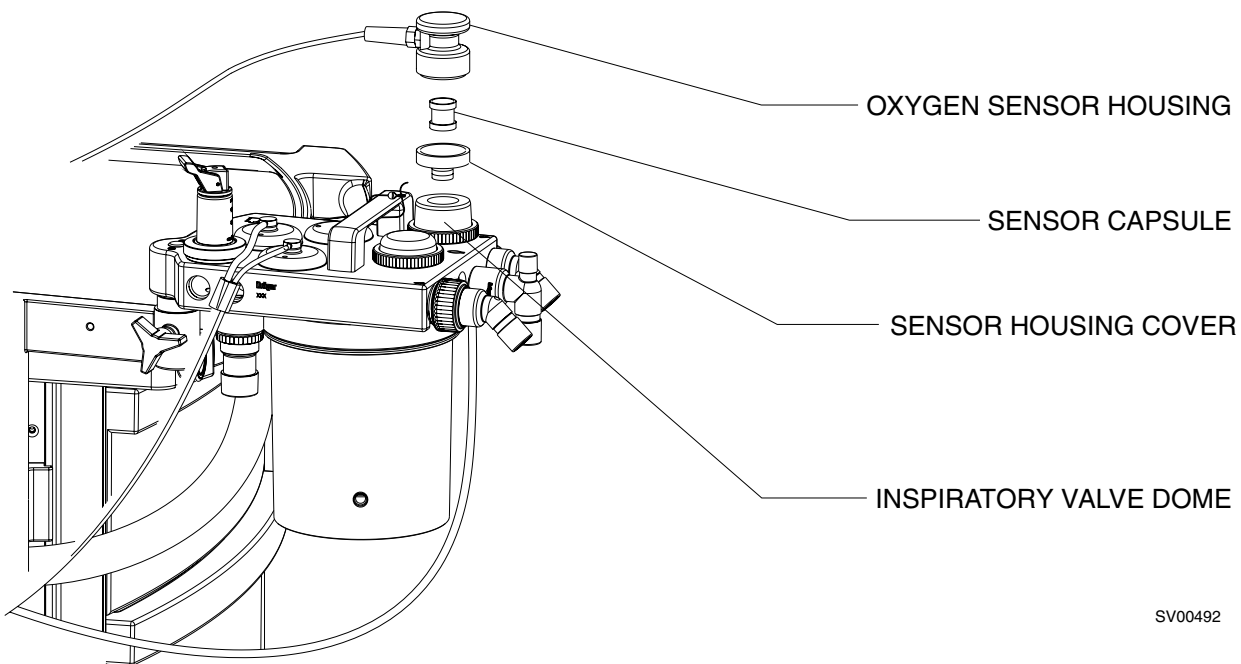

SV00492

Service	9:34		
O2 Calibration			
Current cell A:	66		
Current cell B:	70		
Zero calibration procedure:			
- Remove O2 cell from housing.			
- Let current cell values stabilize.			
- Touch "Store Zero" key to enter the current value as the calibration zero.			
- Reinstall O2 cell in sensor housing.			
Stored zero cell A:	1		
Stored zero cell B:	1		
<table border="1" style="display: inline-table; vertical-align: middle;"> <tr> <td style="padding: 5px;">Store Zero</td> <td style="padding: 5px;">Exit</td> </tr> </table>		Store Zero	Exit
Store Zero	Exit		

Figure 6-5. Oxygen Monitor Service Screen

6.6 Pressure Calibration

- 6.6.1 Set the main power switch to ON.
- 6.6.2 Access the main service screen (ref. Section 4).
- 6.6.3 Scroll to Calibration and select Pressure to bring up the pressure calibration screen. See Figure 6-6.

Zero Calibration:

- 6.6.3.1 Remove the pressure sample line and ventilator hose from the breathing system, and expose the sample line to air.
 - 6.6.3.2 Let the current pressure value stabilize.
 - 6.6.3.3 Touch the “Store Zero” softkey to enter the current value as the calibration zero.
- 6.6.4 Re-connect the pressure sample line and the ventilator hose to the breathing system.
 - 6.6.5 Press the  key to return to the standby screen.

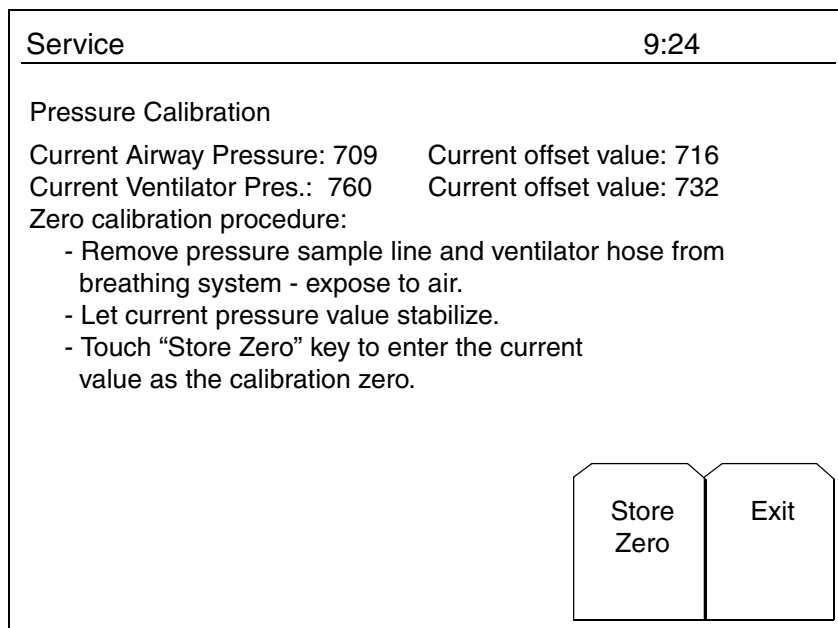



Figure 6-6. Pressure Calibration Screen

6.7 Fresh Gas Flow Calibration

- 6.7.1 Set the main power switch to ON.
- 6.7.2 Access the main service screen (ref. Section 4.0).
- 6.7.3 Scroll to Calibration and select Fresh Gas Flow to bring up the flow calibration screen. See Figure 6-7.
- 6.7.4 Close all flow control valves.
- 6.7.5 Verify no fresh gas flow is present.
- 6.7.6 Touch the “Store Zero” softkey.
- 6.7.7 At completion of calibration “Stored Zero” shall indicate Pass or Fail.
- 6.7.8 Press the  key to return to the standby screen.

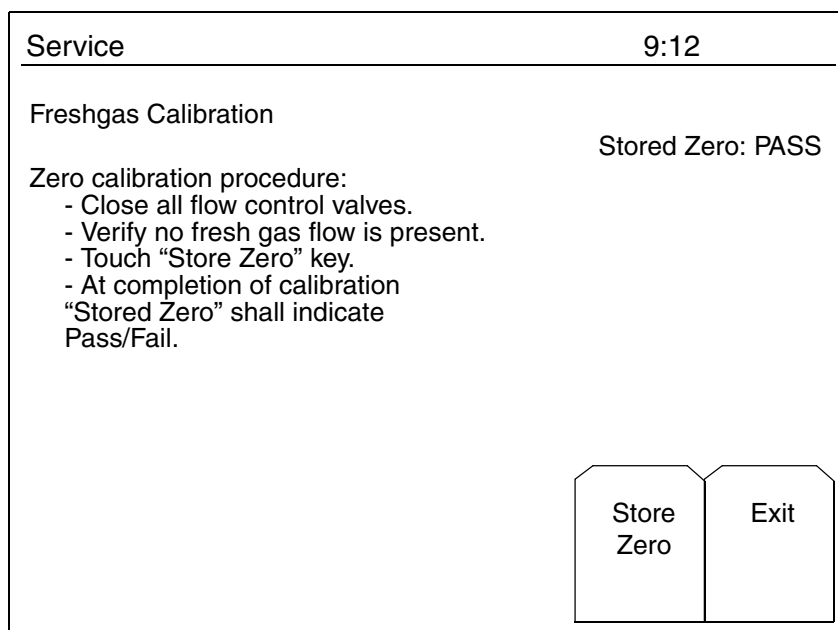

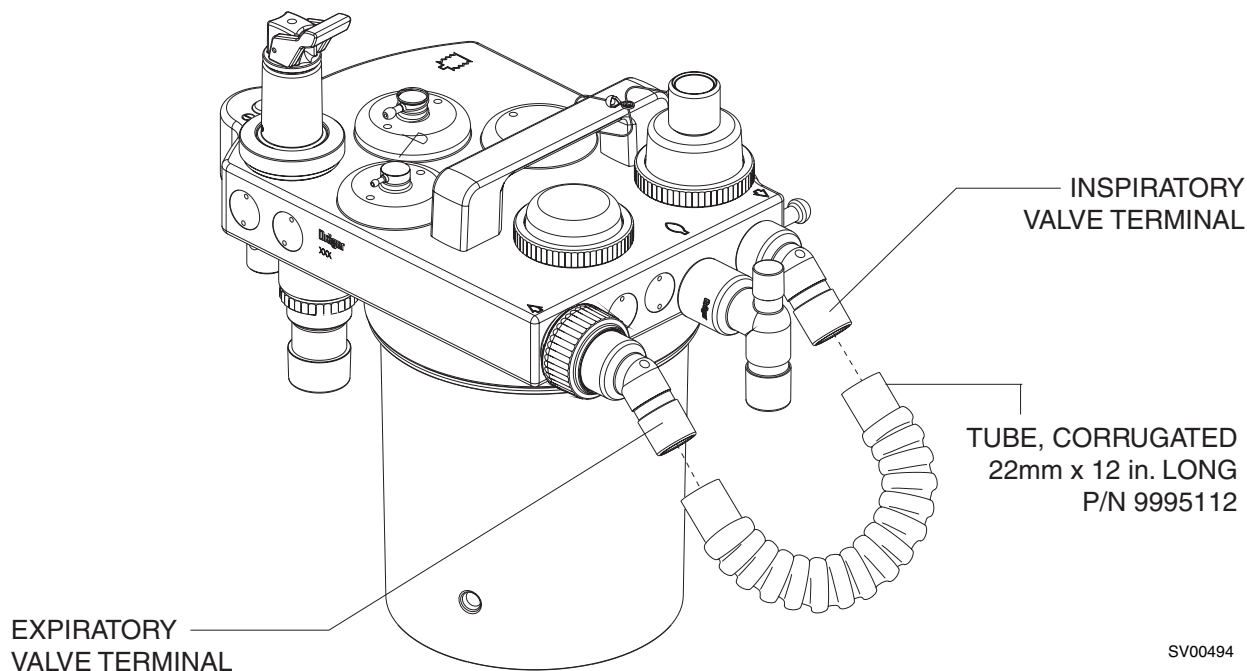

Figure 6-7. Fresh Gas Flow Calibration

6.8 PEEP Valve Calibration

NOTE: Before performing the PEEP valve calibration, a valid pressure calibration and system leak test must be performed first. Otherwise an 'Inv pres. cal' message will appear.

- 6.8.1 Set the main power switch to ON.
- 6.8.2 Access the main service screen (ref. Section 4.0).
- 6.8.3 Scroll to Calibration and select PEEP to bring up the PEEP calibration screen.
- 6.8.4 Attach test hose (P/N 9995112, 22 mm x 12 in long) from the expiratory valve terminal to the inspiratory valve terminal and remove breathing bag.
- 6.8.5 Touch the Calibrate softkey. (The calibration process can take several minutes.)
- 6.8.6 At completion of calibration a "Pass" or "Fail" message will appear.
- 6.8.7 Press the  key to return to the standby screen.
- 6.8.8 Remove the short hose from the inspiratory and expiratory valves.
- 6.8.9 Re-connect the breathing system hoses and breathing bag.



SV00494

Service	10:06		
PEEP Calibration			
	Calibration: PASS		
PEEP calibration procedure:			
- Attach breathing hose from expiratory valve to inspiratory valve and remove breathing bag.			
- Touch "Calibrate" key.			
- At completion of calibration "Calibration" shall indicate Pass/Fail.			
PWM, Pres:	170 44		
Target Pres:	14		
<table border="1" style="margin-left: auto; margin-right: auto;"> <tr> <td style="padding: 5px;">Calibrate</td> <td style="padding: 5px;">Exit</td> </tr> </table>		Calibrate	Exit
Calibrate	Exit		

Figure 6-8. PEEP Valve Calibration Screen

6.9 Vacuum Adjustment

The vacuum adjustment is located on the pneumatic assembly and is accessible by removing the back cover of the controller housing.

- 6.9.1 Remove the back panel from the controller housing. Provide support for the back panel to prevent damage to the power supply cable connections.
- 6.9.2 Set the Main Power switch to ON and set vent control to Volume mode.
- 6.9.3 Remove the APL bypass hose from the breathing system and attach it to a digital manometer.
- 6.9.4 Adjust the variable restrictor on the pneumatic assembly (see [Figure 6-9](#).) until the vacuum is between -150 and -240 cmH₂O (mbar) as shown on the digital manometer.

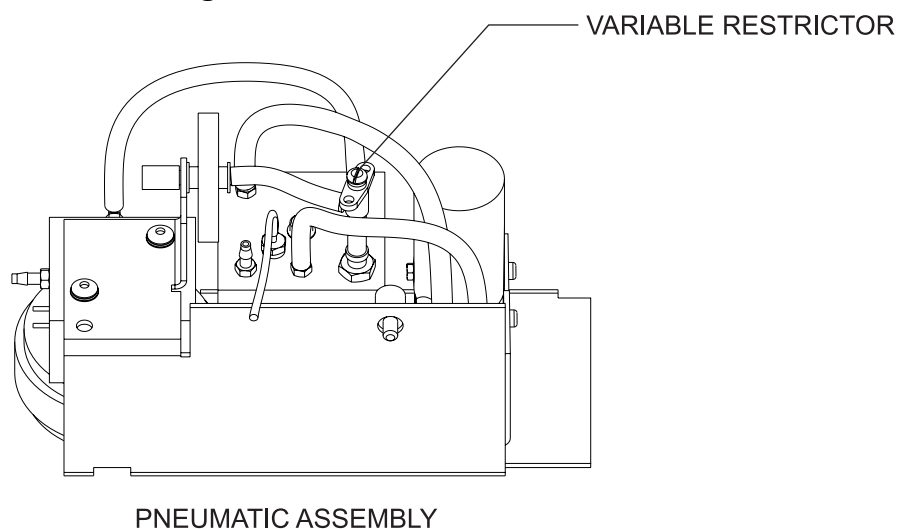

SV00597

Figure 6-9. Vacuum Adjustment (Typical Configuration)

- 6.9.5 Disconnect the APL bypass hose from the digital manometer and reconnect it to the APL port on the breathing system.
- 6.9.6 Reinstall the back panel on the controller assembly.
- 6.9.7 Perform the PMS procedure given in Section [7.0](#).

6.10 Vacuum Pressure Pump Assembly (SW Version 2.X)

6.10.1 Pump Calibration (If Applicable)

NOTE: The ability to calibrate the pump is dependant upon the current PCB installed in the Core Unit.

6.10.1.1 Access the 'System Service Screen' screen and note the installed 'Hardware Part Number'. Refer to Section 4.0.

6.10.1.2 If the 'Hardware Part Number' listed is 4118079, proceed with the next step. If the 'Hardware Part Number' is 4116632, the pump calibration procedure is not available.

6.10.1.3 Access the 'Real Time Values' screen, Refer to Section 4.0.

NOTE: Upon initial entry into this screen, the calibration operation is not active.

NOTE: The pump calibration operation can be performed with the pump in either the ON or OFF state. However, after the calibration operation is complete, the pump will remain in the ON state unless manually turned off. Refer to Section 4.9.

6.10.1.4 Press the 'PUMP CAL' softkey to activate the pump calibration operation. The 'PUMP CAL' label will be highlighted in reverse upon activation and will remain in this condition until the calibration operation is either complete or aborted.

7.0 PMS PROCEDURE, FABIUS GS

The procedures in this section shall be performed in their entirety each time a component is removed, replaced, calibrated, adjusted and during all scheduled Periodic Manufacturer's Service (PMS) visits. A PMS Checklist form, available from DrägerService, shall be completed by the Technical Service Representative (TSR) each time a PMS is performed. Steps in the procedure marked with (✓) require a response at the corresponding line on the checklist form. Space is also provided on the PMS checklist form to record the results of a vapor concentration test. Contact DrägerService for vapor concentration verification procedures.

NOTE: Verify the dates on test equipment calibration labels. **DO NOT USE** any test equipment having an expired calibration date. Notify your supervisor immediately if any equipment is found to be out of calibration.

In the space provided at the bottom of the PMS checklist form, record the Model and ID number of all calibrated test equipment used. Also record the calibration due dates. Examples are: multimeter, digital pressure meter, Riken gas analyzer, safety analyzer, volumeter, trace gas analyzer, simulators.

Description	Page
Test Equipment Required:	7-2
Fabius GS Parts Replacement Schedule:	7-3
Periodic Manufacturer's Certification General Instructions	7-11
7.1 Electrical Safety	7-16
7.2 System Diagnostics	7-18
7.3 Battery Circuit	7-19
7.4 Configuration	7-19
7.5 Service Data	7-19
7.6 Calibrations	7-20
7.7 Site Configurations	7-20
7.8 Scavenger, AGS	7-24
7.9 Breathing System	7-25
7.10 Vapor Interlock System	7-39
7.11 Yokes & Gauges	7-40
7.12 Gas Inlet Regulator Output	7-42
7.13 Cylinder Regulator & Pipeline Gauges	7-46
7.14 High Pressure Leak	7-51
7.15 Oxygen Supply Failure Protection	7-53
7.16 Flowmeters	7-55
7.17 Oxygen Monitor	7-57
7.18 Oxygen Concentrations	7-59
7.19 SORC	7-60
7.20 Pressure Monitor	7-61
7.21 Ventilator	7-63
7.22 Volume Alarms	7-70
7.23 Audio Silence	7-72
7.24 Oxygen Flush Valve	7-73
7.25 Final Tests	7-74

Test Equipment Required:

- Multi-Meter (Fluke or equivalent)
- Electrical Safety Analyzer (Biotek 501 Pro or equivalent)
- Test Pressure Gauge, P/N 4114807 or equivalent
- Fresh Gas Test connector, P/N 4117361 or equivalent
- Fresh Gas Leak Test Device, P/N 4113119 or equivalent
- Test Cap, P/N M33972 or equivalent: two are required
- Adapter Assembly, Test Terminal, P/N 4104389 or equivalent: two are required
- Flowmeter Test Stand (0-250 cc), P/N S000081 or equivalent
- Breathing System Leak Test Device, P/N S010159 or equivalent
- Baromed Pressure Test Fixture or equivalent
- Test Minute Volume Meter, P/N 2212300 or equivalent
- Digital Pressure Manometer (SenSym PDM 200CD or equivalent)
- Riken Gas Indicator, Model 18H, or 1802D or equivalent
- Hose Asm, vapor testing (for use w/Riken gas indicator), 4117905
- Stop Watch
- Siemens Test Lung, P/N 8401892
- Rubber Plug, P/N 7901297
- Tube, Corrugated, 22 mm x 12 in. long, P/N 9995112

Accessories:

- T-connector, P/N M32803
- Washer, M4 white (3x) M31602 (for T-connector above)
- Fitting, Str 1/4 tube x 1/8 NPT, P/N 4109318
- Fitting, Str 0.130 ID hose x 1/8 MPT, P/N 4102963

Materials Required:

- Breathing Bag, 3 liter, P/N 9995330 or equivalent
- DI-Wacker Silicon Rubber, P/N 1202537
- Loctite #222, Purple, P/N 4118558-001
- Loctite #271, Red, P/N 4118558-003
- Loctite #425, Blue, P/N 4118558-008

Repair Tools:

- Plastic Jaw Pliers, P/N 7910296
- Nut Driver (modified), P/N 4117530
- Nut Driver (two-hole spanner). P/N 7910305
- Cable Assembly, flash load RAM, P/N 4117459
- Nut Driver, 3/8 in.
- Cable Assembly, Vitalink, P/N 4110328
- Hose cutter, P/N 7900894
- Spanner Wrench, Insert/Extraction, P/N 4118165
- Scalpel P/N 4118169
- Spanner Wrench, Bag Arm Extension, P/N 4117773
- Pozi Drive Set
- Wrench, Caster, P/N S010055

Test equipment illustrations are shown on following pages.

Fabius GS Parts Replacement Schedule:

Quantity	Description	Part Number	Alternate Part Number
As Required			
1	Flow Sensor (5 pack)	8403735	
1	O2 Sensor	6850645	
2	O-ring, Vent Hose	2M08777	
2	Valve Disc	2123249 or M23225	
1	Hose asm, PEEP/Pmax - APL Bypass	4117027	
1	Hose, Pressure	1190520	
1	Filter, AGS	M33294	
Annually: Fabius GS/Tiro 1 year kit		4117360-001	4199912
2	Filter, Pressure & Pneumatic asm	8402868	
1	Diaphragm, Patient	2600650	
4	O-ring, Vapor	4115864	
1	O-ring, for Diaphragm (piston)	8604831	
Every 3 Years: Fabius GS/Tiro 3 year kit		4117360-002	4199911
1	Diaphragm, Piston	2600651	
2	Battery, 12V Rechargeable	4114229	
1	Canister Assembly	M29320	
1	Lip Seal	M30455	
1	Packing Ring	M30456	
1	PM Kit; 1 Year	4117360-001	4199912

Disposal of used batteries and O2 Sensors:

- Batteries must be disposed of in conformity with local waste disposal regulations.
- Expired O2 sensors can be returned to:
 - Dräger Medical AG & Co. KGaA
 - Moislinger Allee 53-55
 - Reparaturannahme
 - 23542 Lübeck
 - Germany
- Do not open forcibly: danger of chemical burns.
- Do not incinerate: danger of explosion.

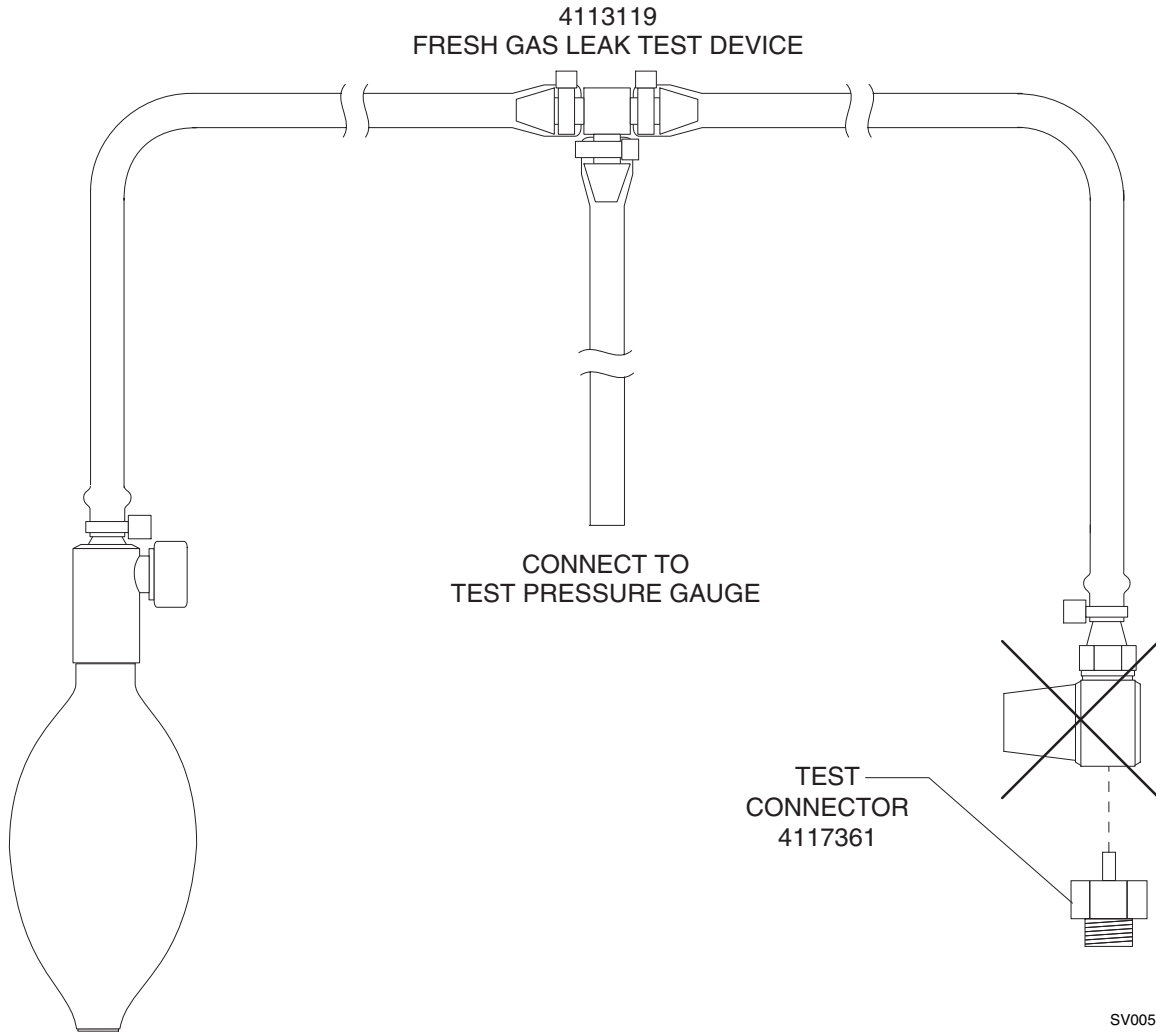

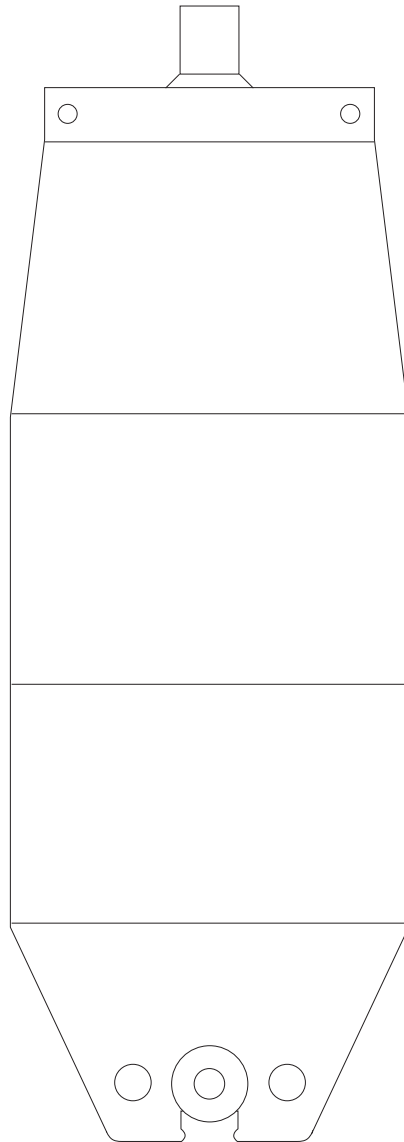

8401892
SIEMENS TEST LUNG

SV00025

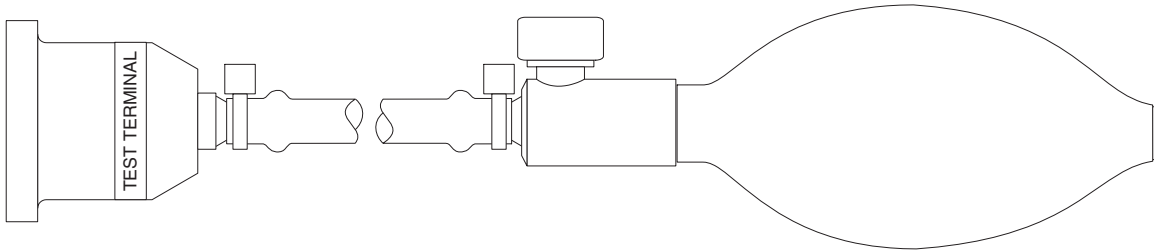

S010159
BREATHING SYSTEM LEAK TEST DEVICE

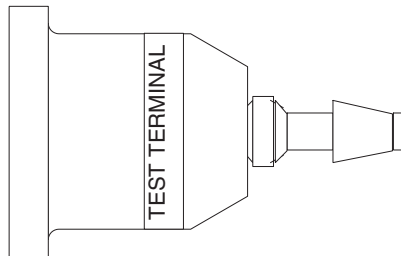

4104389
TEST TERMINAL
ADAPTER

SV00515

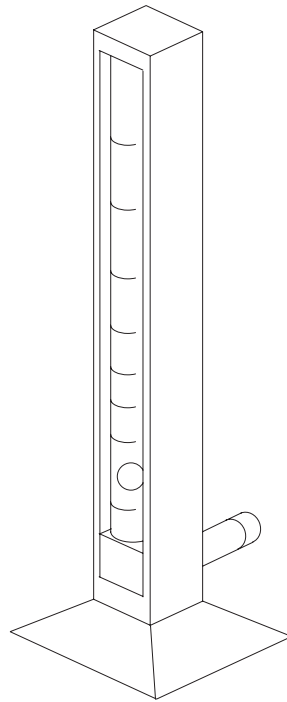

SV00559

S000081
FLOW METER
TEST STAND
0-250cc/MIN

3V00552

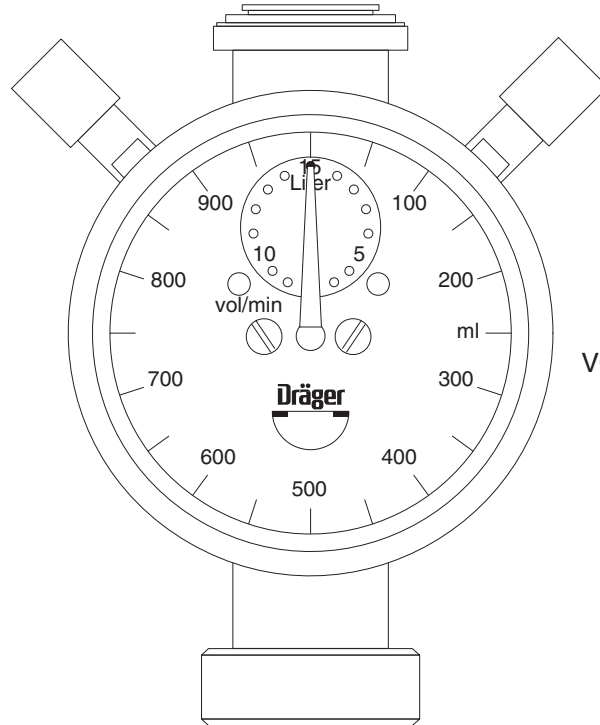

2212300
MINUTE
VOLUMETER

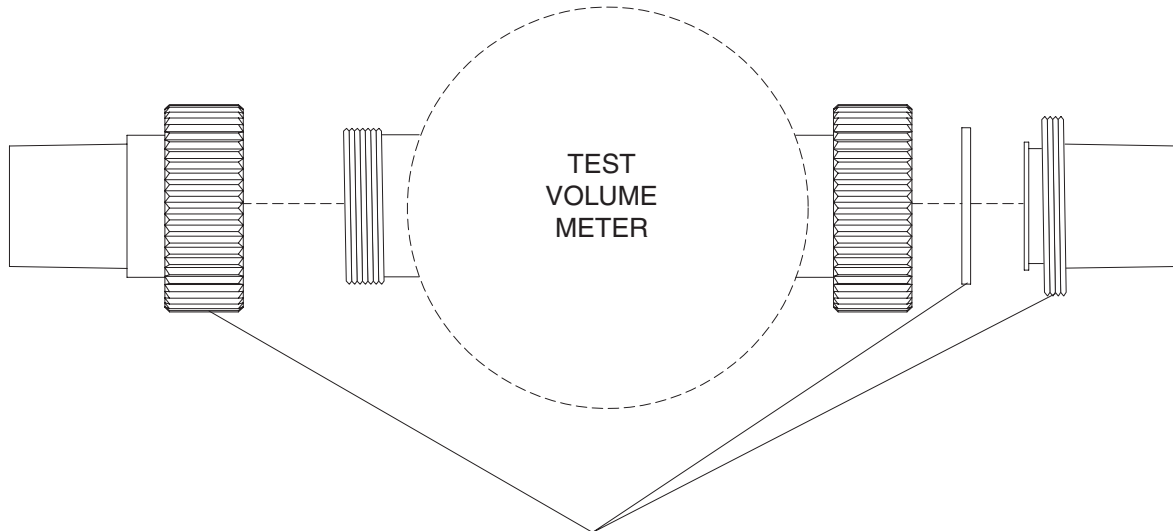

4115087 33mm x 22mm ADAPTER

M33972
TEST CAP

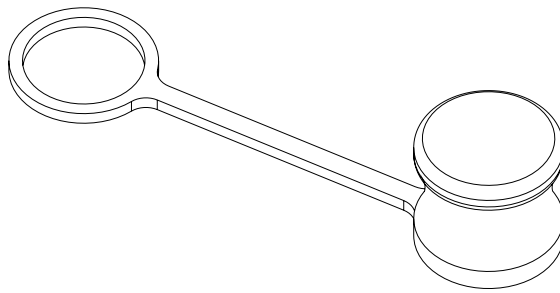

SV00516

4114807 PRESSURE TEST ASSEMBLY , WITH ADAPTERS

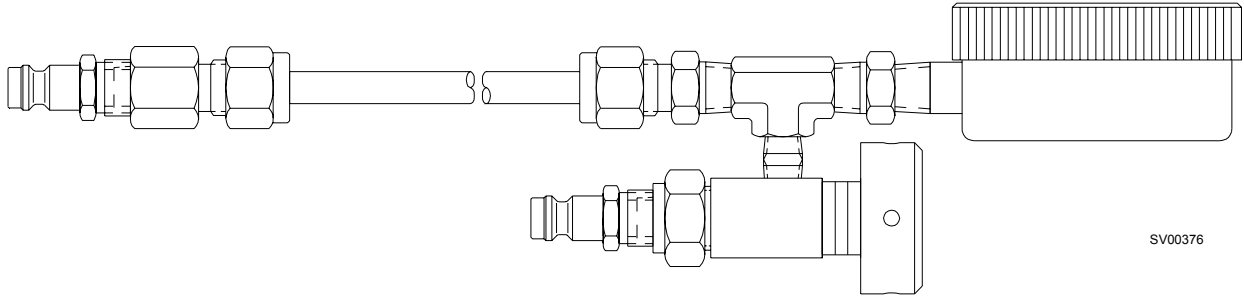

SV00376

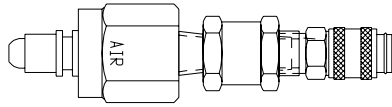

4114830-002

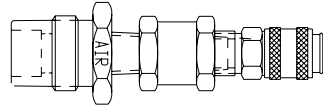

4114830-001

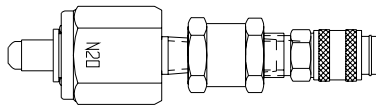

4114830-004

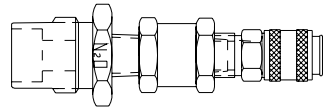

4114830-003

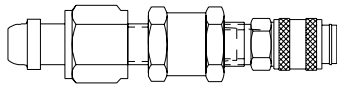

4114830-006

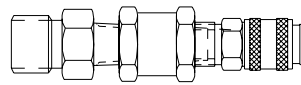

4114830-005

Periodic Manufacturer's Certification General Instructions

The purpose of these procedures is to provide detailed instructions for performing a Periodic Manufacturer's Certification (PMC) inspection on the Fabius GS anesthesia machines.

A PMC consists of a complete Periodic Manufacturer's Service procedure and a certification level inspection based on Draeger Medical, Inc. Recommendations and equipment performance. Additional inspections are also performed to ensure proper product labeling.

Several additional documents have been created to assist the technician through the process. Following is a brief description of the purpose of each document.

Field Service Procedure:

Periodic Manufacturer's Certification Forms - Part Number SP00175.

This procedure illustrates the sample checklists with typical periodic maintenance items filled in, including vapor concentration verification tests, parts replaced, general comments and certification levels. Also included are sample PMC labels marked to show several levels of certifications. An excerpt from Draeger Medical, Inc.'s *Anesthesia System Risk Analysis and Risk Reduction* is included, and also a sample of an Executive Summary to be furnished to the hospital's Risk Manager or Chief of Anesthesia.

Field Service Procedure:

NAD Recommendation Guidelines Index Anesthesia Systems - Part Number S010250.

This Guideline was created to provide an assessment of each machine's certification. It contains various comprehensive overviews of possible equipment conditions and their associated certification levels.

The first list in the Recommendation Guidelines is a reference chart for machine certification based on equipment status. The second is an abbreviated summary of all NAD Recommendations and Failure Codes including the Condition Number, Equipment Condition, Recommended Corrections, Certification Code, and Tests Affected when applicable.

There is also a matrix classified as "Failure Codes" which identifies the correct manner in which to document equipment tests that fail, or were unable to be performed due to circumstances beyond the control of the service technician performing the inspection. (Ex: Air cylinder supply is unavailable to perform Air High Pressure Leak test.) The Failure Codes section also indicates suggested resolution of the situation. Failure Code numbers begin at 34 and use the same certification levels strategy, and carry the same weight as NAD Recommendation equipment condition codes.

The next section of the guideline lists all NAD Recommendations identified at a machine's major assembly level. This section is divided into subsections titled: "Anesthesia System", "Vaporizers", "Absorber System", "Ventilator" and "Scavenger System". The final matrix is the most comprehensive index sorted by machine model and includes Equipment Condition, Certification Code, and NAD Recommendations. It also specifies any suggested upgrade path including ordering information that should be taken such as installing a Bellows with Pressure Limit Control 4109664-S01 Kit, after market modification kit to a machine not equipped with pressure limit control.

The letters A, B, C, D and the Roman Numerals I, II are used as codes in the individual matrix for each model of anesthesia machine. The letters A, B, C, and D are used in descending order to indicate the certification level of the equipment. They are as follows:

- A = Certified
- B = Certified with Recommendations
- C = Conditionally Certified
- D = No Certification

Roman Numerals I and II do not affect the certification level but rather are provided to give further instructions to the end user as follows:

- I = The system in its present configuration shall only be used with a CO2 monitor incorporating an apnea warning. The operator of the system is advised to frequently scan the CO2 readings and alarm thresholds.
- II = The present configuration of equipment requires that the unit operate at all times with an oxygen analyzer that includes a low oxygen warning. The operator of the system is advised to frequently scan the oxygen readings and alarm limits.

Following is an explanation of machine certification levels:

Certified- No recommendations apply to machine being inspected. (Only item number 33 - "No Recommendations" shall apply for this certification level.)

Certified with Recommendations- A numbered recommendation with a code of B applies to the machine being examined.

Conditionally Certified- A numbered recommendation with a code of BC, BCI or BCII applies to the machine being examined.

No Certification- A numbered recommendation with a code of D applies to the machine being examined.

When multiple recommendations apply, use the above list in descending order from bottom to top. For example, "No Certification" would take precedence over "Conditionally Certified" and "Certified with Recommendations". "Conditionally Certified" would take precedence over "Certified with Recommendations".

For example:

A **Narkomed Standard** or **Compact** could have recommendation numbers 10, 11 and 15 apply.

10 - Breathing pressure monitor is not interfaced with anesthesia machine system power switch or ventilator. Code is B.

11 - Ventilator is equipped with descending bellows and lacks CO2 monitoring. Code is D1.

15 - Vaporizer mounting using a vaporizer selection valve. Code is B.

The correct certification for this machine is D, which means "NO CERTIFICATION", and additional recommendation I applies.

A **Narkomed AMIII** or **Narkomed II** could have recommendations 6 apply, and failure code 46.2.

6 - Oxygen ratio monitor instead of oxygen ratio monitor controller. Code D II.

46.2 - O₂ analyzer malfunction. Code D.

Correct certification for this machine is D, which means "NO CERTIFICATION".

A **Narkomed 2A** could have recommendation numbers 12, 14 and 27 apply.

12 - No integrated exhaled CO₂ monitor with user adjustable alarm limits. Code D1.

14 - CO₂/Agent monitor exhaust port is not properly connected to waste gas disposal system. Code B.

27 - Ventilator bellows assembly has a PEEP valve assembly. Code B.

Correct certification for this machine is D1, which means "NO CERTIFICATION", and additional recommendation I applies.

A **Narkomed 3** could have recommendation number 21 and failure code 61.1 apply.

21 - No ventilator pressure limit control. Code is B.

61.1 - Enflurane agent is unavailable to test. Code is BC.

Correct certification for this machine is BC, which means **CONDITIONALLY CERTIFIED WITH RECOMMENDATIONS**.

A **Narkomed 4** could have recommendation numbers 14 and 21 apply.

14 - CO₂/Agent monitor exhaust port is not properly connected to the waste gas scavenger. Code B.

21 - No ventilator pressure limit control. Code B.

The correct certification for this machine is B, which means "CERTIFIED WITH RECOMMENDATIONS".

A **Narkomed 2B, 2C** or **GS** could have recommendation 30 apply.

30 - Anesthesia machine is equipped with inhalation anesthesia vaporizers without an agent analyzer in the breathing system. Code B.

The correct certification for this machine is B, which means "CERTIFIED WITH RECOMMENDATIONS".

A **Narkomed 6000** could have no NAD recommendations or failure codes apply. The correct certification level for this machine is Code A, "CERTIFIED".

Code D, which means "NO CERTIFICATION", also means the machine shall not receive a Periodic Manufacturer's Certification label. The machine shall also receive a "WARNING - This System is Not Certified" label, P/N 4114857. This label shall be placed at a prominent location on the right side of the machine after all other previous PM and "Vigilance Audit® Validation" labels have been removed.

PM Certification Procedure for Fabius GS Anesthesia System

1. Use the PM Certification form P/N 4117715 for the Fabius GS Anesthesia System.
2. Completely fill in the header information.
3. Perform the vapor concentration test on all Dräger vapor vaporizers every six months in accordance with SP00073 at a six month maximum interval. Perform the vaporizer concentration test on all Desflurane vaporizers in accordance with SP00091 for fixed mount vaporizers and SP00189 for user removable D-tec vaporizers at a six month maximum interval. For every vaporizer tested, fill out a “VAPOR VAPORIZER CALIBRATION CHECK” label (part # S010016). Information on this label shall include your signature, type of agent, date tested, test results @ 1%, 2.5%, 4% for H, E, I, or S vaporizers, or @ 4%, 6%, 10%, 12%, 16% for Desflurane vaporizers, and a PASS or FAIL indication. This label shall be attached to the upper right side of the vaporizer. If vaporizer fails the concentration verification, internal leak, or exclusion system tests, check “NO” in the “RECOMMENDED FOR USE” section on the PM Certification form.

Place a “CAUTION DO NOT USE” label (part # 4114327) on the vaporizer, and issue a departmental alert. The TSR shall also seek permission from the equipment operator to remove the failed vaporizer from the machine and install a replacement vaporizer or an adapter block onto the mount. All nonfunctional Dräger vaporizers must be removed from service for machine to receive certification.

4. Proceed with PM Certification in accordance with Section 7. If any tests fail refer to the “Failure Codes” listing in NAD Recommendations Guidelines Index, P/N S010250, to determine correct certification level starting point. Failure codes shall be documented on the “RECOMMENDATIONS / GENERAL COMMENTS” section of the PM Certification form and on the Executive Summary if applicable. If a test fails that has not been identified by the “Failure Codes” list, consult with Draeger Medical, Inc. to assess the proper certification level.

PM Certification Procedure for Fabius GS Anesthesia System

5. Based on the "EQUIPMENT CONDITION" inspect the machine for any "NAD RECOMMENDATIONS" that would apply. Use the Fabius GS section of the "NAD RECOMMENDATION GUIDELINES INDEX", P/N S010250. Note all applicable NAD recommendations on the Executive Summary. NOTE: If using a carbon form, indicate the Equipment Condition number and to see reverse side under "RECOMMENDATIONS / GENERAL COMMENTS" section of the form.
6. Determine the correct certification level of the machine based on the combined lowest common denominator of "Equipment Conditions" and "Failure Codes". If the machine is at least conditionally certified, fill out the "PM CERTIFICATION" label. Check the box(s) on the validation label where appropriate. Write the month and year, (six months from date of PM Certification) next to "NEXT VISIT DUE:" If certification level is "D", machine shall not receive a "PM CERTIFICATION" label. Any machine not receiving a PM Certification label shall receive a "WARNING NOT CERTIFIED" label. This label shall be placed at a prominent location on the left side of the machine after all other previous PMS and Vigilance Audit Validation labels have been removed.
7. In the "CERTIFICATION LEVEL" section of the PM Certification form, record the last visit certification level, the current certification level and the next visit due month and year, (six months from date of PM Certification) in the spaces provided.
8. If applicable, remove the previous PM CERTIFICATION VALIDATION label and attach the new label in a prominent location on the rear of the anesthesia machine.
9. Check the appropriate boxes on the "PM CERTIFICATION NOTICE" label, (part # S010011). If the machine is not certified, the last box of this notice label shall be checked. Attach this notice to the flow shield of the anesthesia machine.
10. Have the customer sign each PM Certification form or the Executive Summary, and review the equipment conditions and recommendations with the customer.
11. Return the top copy to Draeger Medical, Inc. Service Department, keep middle copy for service organization records, give bottom copy to customer.

NOTE: The following procedure will require making adjustments and calibrations with the possibility of removal of accessories and/or additional monitoring equipment. Therefore, take note of these devices for reconfiguration and/or reinstallation after the PMS procedure is complete.

7.1 Electrical Safety

(✓) 7.1.1 Protective Ground Continuity

7.1.1.1 Turn the System Power switch to STANDBY.

Plug the unit into the safety analyzer, and plug the power cord of the safety analyzer into an AC receptacle. Turn analyzer to ON position.

NOTE: The BIOTECH 501 PRO will automatically test the source outlet for open ground (or ground resistance of 31Ω or higher), reverse polarity, open neutral and open line. (The latter two conditions will prevent the analyzer from powering up.)

7.1.1.2 Set the safety analyzer function switch to the GROUND WIRE RESISTANCE position. Attach the test lead to the SINGLE LEAD connector of the analyzer. Connect the other end of the red test lead to the ground socket of the front panel outlet on the safety analyzer. Verify a displayed resistance of 0.000Ω or, if necessary, press the CALIBRATE key on the front panel of the analyzer to zero the device.

7.1.1.3 Set the safety analyzer GROUND switch to NORMAL. Set the POLARITY switch to OFF.

7.1.1.4 The safety analyzer shall indicate 0.1Ω or less with its test lead applied to the following points:

- Cylinder yoke (if applicable)
- Serial port cable retaining nut on processor
- Vaporizers
- Push/pull handle
- GCX rails

(✓) 7.1.2 Circuit Isolation (If Applicable)

NOTE: This test is not applicable on machines with serial numbers 12191 to 12334.

- 7.1.2.1 With a multimeter set to its highest resistance range, check for continuity between the serial port cable retaining nut on processor and the O2 sensor connector pin shown in the illustration. There shall be no continuity between these points.

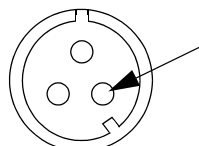

O2 SENSOR

(✓) 7.1.3 Auxiliary Outlet Strip (if applicable)

NOTE: This test will check the auxiliary strip outlets for fault conditions such as open ground ($>31 \Omega$), reverse polarity, open line and open neutral. This is done each time the BIOTECH 501 PRO is powered up and allowed to cycle through its self test.

- 7.1.3.1 Shut off and unplug the safety analyzer. Remove the anesthesia machine plug from the analyzer, and plug it into the same outlet that was being used by the analyzer.
- 7.1.3.2 Plug the safety analyzer into the first outlet to be tested, and turn the analyzer power switch ON. Allow the analyzer to cycle through its Auto Test sequence. If no wiring fault is indicated, shut off the analyzer and move its plug to the next outlet. Test this outlet in the same manner, and continue until all convenience outlets on the auxiliary strip outlets are tested.

7.1.4 Chassis Leakage Current

- 7.1.4.1 Turn the anesthesia machine System Power switch to ON and set the safety analyzer to the CHASSIS LEAKAGE CURRENT position.
- 7.1.4.2 Attach the safety analyzer test lead to a rear GCX rail.

- (✓) 7.1.4.3 Record the total leakage current with the Polarity and Ground switches set as follows:

Ground	Polarity
Open	Normal
Normal	Normal
Open	Reversed
Normal	Reversed

Verify that the leakage current is 300 microamps or less in each of the switch positions (500 microamps or less for the 220/240 volt power supply option).

- (✓) **7.2 System Diagnostics**

- 7.2.1 Connect the pipeline supply or open the cylinders.
- 7.2.2 Push the System Power switch to ON (☉).
- 7.2.3 Verify that the following is displayed and system diagnostics indicate a “Pass” condition:

SYSTEM DIAGNOSTICS	System Status
Watch Dog	Pass
System RAM	Pass
Program Memory	Pass
Video Test	Pass
Interrupts	Pass
A/D Converter	Pass
NV RAM	Pass
Serial Port	Pass
Clock	Pass
Speaker	Pass
Main Power	Pass
Battery	Pass
 Fabius GS SW XX	

- (✓) 7.2.4 Record the machine software version on the header of the checklist form.

(✓) **7.3 Battery Circuit**

- 7.3.1 Press the Man Spont key, and press the rotary dial to confirm.
- 7.3.2 Unplug the AC power cord and verify the “Power Fail” message appears on the display within one minute.
- 7.3.3 Restore AC power to the machine and verify the “Power Fail” message disappears within one minute.

(✓) **7.4 Configuration**

- 7.4.1 Press the Standby key, then press the rotary key to confirm.
- 7.4.2 Press the Setup key, and press the rotary dial to confirm.

Default Settings:

- 7.4.3 Verify all parameters listed in the ‘Default Settings’ screen are adjustable.
- 7.4.4 Adjust the Alarm Volume to its highest setting and press the rotary dial to confirm.
- 7.4.5 Press the rotary dial once to return to the Setup screen.

Configuration:

- 7.4.6 Using the rotary dial, scroll to Configuration and press the rotary dial to confirm.
- 7.4.7 Verify all parameters listed in the ‘Configurations Settings’ screen are adjustable and correct per local configurations. Press to confirm two times to exit Setup mode.

7.5 Service Data

- 7.5.1 Press and hold the Home and Standby keys, and press the rotary dial. Verify the System Service screen appears.
- (✓) 7.5.2 Verify on-screen serial number with machine serial number located on rear of unit, and record on header of PMS form.
- (✓) 7.5.3 Record the Last Service Date, Hours Run Since Last Service, Total Hours Run, and Total Ventilator Hours Run on the PMS form.
- 7.5.4 Press the rotary knob to go to the Main Service screen.
- 7.5.5 Scroll to Preventative Maintenance, then to Activate.
- 7.5.6 Change the Preventative Maintenance date to reflect next PM due date. Press the rotary dial once to return to the main service screen.

- (✓) 7.5.7 Inspect the condition of the ventilator (piston diaphragm) O-ring. Is the O-ring in good condition? (Y)
- (✓) 7.5.8 If applicable, install the appropriate PM kit(s) and record in Parts Replacement section of PM form. See Parts Replacement Schedule on [page 3](#).

7.6 Calibrations

Fresh Gas Flow:

- 7.6.1 Scroll to Calibration and press to confirm.
- 7.6.2 Scroll to Fresh Gas Flow and confirm.
- 7.6.3 Follow on-screen instructions and perform Fresh Gas Flow calibration.
- (✓) 7.6.4 Verify Stored Zero indicates Pass (Y)
- 7.6.5 Press the Exit key.

Pressure:

- 7.6.6 Scroll to Pressure and confirm.
- (✓) 7.6.7 Follow the on-screen instructions and perform the Zero calibration. Reconnect pressure line and ventilator hose to breathing system.
- 7.6.8 Press the Exit key, then scroll to O2 and confirm.

O2 Offset:

- (✓) 7.6.9 Follow the on-screen instructions and perform the O2 zero calibration. Reassemble O2 housing and install the inspiratory dome plug in inspiratory dome.

PEEP:

NOTE: Before performing the PEEP valve calibration, a valid pressure calibration must be performed. Otherwise, an 'Inv pres. cal' message will appear.

- 7.6.10 Press the Exit key; scroll to PEEP and confirm.
- (✓) 7.6.11 Follow the on-screen instructions to calibrate PEEP. Verify PEEP calibration indicates PASS (Y).
- 7.6.12 Press Exit, then confirm (2x).

7.7 Site Configurations

- 7.7.1 Scroll to Configure and confirm.

O2 Position (virtual flowtubes):

- (✓) 7.7.2 Scroll to Flowmeter and confirm. Scroll to O2 Position and confirm. Select position of virtual flowmeter (left or right) in accordance with local requirements or customer demand. Press to confirm. record position on PMS form.

Gas Selection:

- (✓) 7.7.3 Press to confirm, scroll to Gas Selection and confirm. Verify Gas Selection type (2 or 3) is in accordance with machine configuration. Press to confirm (x2). Record selection type on PMS form.

Flowtube Resolution:

- 7.7.4 Scroll to Flowtube Res. and press to confirm. Scroll to change state and confirm. Scroll to change state in accordance with customer demand.

O2 Whistle:

- (✓) 7.7.5 Press to confirm, scroll to O2 whistle. Verify O2 whistle selection (enabled or disabled) is in accordance with local requirements or customer demand. Press to confirm (x2). Record position on PMS form.

Alarms:

- (✓) 7.7.6 Scroll to No Fresh Gas and confirm. Verify state of No Fresh Gas alarm is enabled. Press to confirm (x2). Record position on PMS form.
- (✓) 7.7.7 Scroll to Fresh Gas Low Alarm. Verify Fresh Gas Low Alarm position (enabled or disabled) is set to enabled position. Press to confirm (x2). Record position on PMS form.
- (✓) 7.7.8 Scroll to Threshold Low and confirm. Verify state of Threshold Low Alarm is enabled. Press to confirm (x2). Record position on PMS form.

Pressure:

- (✓) 7.7.9 Scroll to Ambient Pressure and confirm. Turn rotary dial to adjust. Press to confirm (x2). Record pressure setting on PMS form.

NOTE: Using the table found on the following page, set the ambient pressure (mbar) in accordance with the local elevation. To verify the local elevation, contact the nearest regional airport, or contact:

DMI - Technical Support - 1-800-543-5047
DMT - Tech Line - 49-451-882-4222

- 7.7.10 Scroll to Plateau/Mean Dis and verify setting is in accordance with customer demand. Press to confirm (x3).
- 7.7.11 If Software Version 2.X is installed, scroll to the 'System Settings/ Model Type' screen and confirm. Verify 'Model Type' listed is consistent with actual unit.

NOTE: Machines from the factory are configured with the appropriate model type. Other than performing a software download or PCB replacement, the model type should not be changed. Changing the model type will disable some ventilator options and will require reconfiguration.

Serial Ports:

- (✓) 7.7.12 Scroll to Serial Ports and confirm. Verify parameters are adjustable to the following protocols. If necessary, set the protocols for any third party monitoring device connected to the machine. Refer to the Fabius GS Operator's Manual and third party Operator's Manual.

Baud Rate:	1200, 2400, 4800, 9600, 19200, 38400
Parity:	NONE, ODD, EVEN
Stop Bits:	1, 2
Data Bits:	7, 8
Protocol:	Vitalink - Medibus

NOTE: It is important to ensure that communication protocols selected on each host and external device are correct. Vitalink and Medibus protocols are similar and if not set identically on each device, inaccurate data may be displayed on the remote device.

- 7.7.13 Press Standby key to exit.

Elevation Range in Feet	Elevation Range in Meters	Barometric Pressure Setting
-200 - 199	-60 - 60	1013
200 - 599	61 - 182	1000
600 - 999	183 - 304	985
1000 - 1399	305 - 426	970
1400 - 1799	427 - 548	960
1800 - 2199	549 - 670	945
2200 - 2599	671 - 792	930
2600 - 2999	793 - 914	920
3000 - 3399	915 - 1036	905
3400 - 4199	1037 - 1158	890
3800 - 4199	1159 - 1280	880
4200 - 4599	1281 - 1401	865
4600 - 4999	1402 - 1523	855
5000 - 5399	1524 - 1645	840
5400 - 5799	1646 - 1767	830
5800 - 6199	1768 - 1889	820
6200 - 6599	1890 - 2011	805
6600 - 6999	2012 - 2133	795
7000 - 7399	2134 - 2255	785
7400 - 7799	2256 - 2377	770
7800 - 8199	2378 - 2499	760
8200 - 8999	2500 - 2620	750
8600 - 8999	2621 - 2742	740
9000 - 9399	2743 - 2864	730

(✓) **7.8 Scavenger, AGS**

Scavenger Cleaning

- 7.8.1 Remove all scavenger hoses one at a time and drain all accumulated moisture. Inspect all scavenger hoses for deterioration and replace any worn hoses.
- 7.8.2 Disconnect the hospital vacuum source from the scavenger.
- 7.8.3 Remove the reservoir canister from the scavenger by partial turn counter-clockwise of the canister.
- 7.8.4 Remove and inspect the silencer; replace if needed.
- 7.8.5 Remove the flowmeter from the scavenger by turning the mounting nut counter-clockwise. Inspect the tube and clean with compressed air if needed.
- 7.8.6 Reassemble the scavenger assembly, and reactivate the vacuum source.

Scavenger, AGS Functional Test

- 7.8.7 Verify vacuum hose is connected to one of the two gas supply connections.
- 7.8.8 Verify the additional gas surplus connection is plugged.
- 7.8.9 Verify all hose connections to the scavenger are complete at all destinations.
- 7.8.10 Verify vacuum waste disposal system at manifold is active.
- 7.8.11 Reinstall canister and adjust scavenger flow control valve; verify float moves freely between the upper and lower limits.

7.9 Breathing System

- (✓) 7.9.1 Breathing System Inspection
 - (✓) 7.9.1.1 Record the serial number (located on the side of the COSY) on the PMS form.
 - 7.9.1.2 Remove the inspiratory and the expiratory valve domes.
 - 7.9.1.3 Is there a broken or bent pin on the valve assembly?
Inspiratory ___ (N) Expiratory ___ (N)
 - 7.9.1.4 Is there a broken pin on the valve domes?
Inspiratory ___ (N) Expiratory ___ (N)
 - 7.9.1.5 Is the valve disc in good condition?
Inspiratory ___ (Y) Expiratory ___ (Y)
 - 7.9.1.6 Is there excessive wear on the valve craters?
Inspiratory ___ (N) Expiratory ___ (N)
 - 7.9.1.7 Are the valve dome washers in good condition? ___ (Y)
 - 7.9.1.8 Reinstall the inspiratory and expiratory valve domes.
 - 7.9.1.9 Un-screw the 22 mm expiratory port. Is the O-ring inside the port and 22mm taper in good condition? ___(Y)
 - 7.9.1.10 Remove the flow sensor from the breathing system housing. Is the O-ring inside housing in good condition? ___(Y)
 - 7.9.1.11 Reinstall the flow sensor and expiratory port.
 - 7.9.1.12 Remove the canister and inspect the canister, gaskets, and condition of soda lime. Are these components in good condition? ___(Y)
 - 7.9.1.13 Remove the breathing pressure gauge from its mount and inspect the O-rings in the mount and on the 90° hose connection - if applicable.
 - 7.9.1.14 Is the breathing pressure gauge in good condition and set at zero (0)? ___ (Y) (if applicable)
 - 7.9.1.15 Inspect the O-rings on the inspiratory dome plug assembly and O2 sensor housing. Are the O-rings in good condition? ___(Y)

- 7.9.1.16 Examine all pneumatic hoses connecting from the interface panel to the breathing system. Are the hoses kink free and in good condition? ___(Y)
- 7.9.1.17 Inspect the breathing circuit and manual breathing bag. Is the breathing circuit and manual breathing bag in good condition? ___(Y)
- 7.9.1.18 Inspect the ventilator hose and associated O-rings connected between breathing system and machine. Are the hose and O-rings in good condition? ___(Y)
- 7.9.1.19 Inspect the fresh gas hose connected to the breathing system. Is the fresh gas connector and washer in good condition? ___(Y)
- 7.9.1.20 Inspect APL valve labeling for legibility. Are all markings on APL valve easy to see and legible? ___(Y)
- 7.9.1.21 Inspect the scavenger gas connection on the breathing system. Is the scavenger connector in good condition? ___(Y)

7.9.2 Fresh Gas Leak

- 7.9.2.1 Push the System Power switch OFF ($\overset{\bullet}{\circ}$).
- 7.9.2.2 Remove the fresh gas connector from the breathing system.
- 7.9.2.3 Connect the fresh gas hose from the breathing system to the fresh gas leak test fixture (4113119 modified) or equivalent, via the fresh gas test connector 4117361.
- 7.9.2.4 Connect a digital pressure manometer to the fresh gas leak test device.
- 7.9.2.5 Apply 50 cm H₂O of pressure to the system.
- (✓) 7.9.2.6 After thirty (30) seconds, what is the pressure on the manometer? ___ (>40 cm H₂O)
- 7.9.2.7 If applicable, turn on the left mounted vaporizer to the first graduated marking.
- 7.9.2.8 Apply 50 cm H₂O of pressure to the system.
- (✓) 7.9.2.9 After thirty (30) seconds, what is the pressure on the manometer? ___ (>40 cm H₂O)
- 7.9.2.10 Turn off the vaporizer.

- (✓)
- 7.9.2.11 If applicable, turn on the right mounted vaporizer to the first graduated marking; repeat Steps 7.9.2.5 thru 7.9.2.10 ____ (>40 cm H₂O)
 - 7.9.2.12 Remove the test equipment from the fresh gas hose.
 - 7.9.2.13 Push the System Power switch ON (⊙).
 - 7.9.2.14 Open the O₂ flow control valve to 5 L/min., purge the system for 5 seconds, then close the O₂ flow control valve.
 - 7.9.2.15 Push the System Power switch OFF (⊙).
 - 7.9.2.16 Reconnect the fresh gas connector from the machine to the freshgas outlet connector on the breathing system.

(✓) 7.9.3 Breathing System Leak

NOTE: Use the appropriate column in the following table - according to the software version of the machine you are testing:

	Software ≤ 1.20	Software ≥ 1.30 (USA) Software ≥ 1.2x (non-USA)
7.9.3.1	Verify the System Power switch is On	
7.9.3.2	Press Run Leak Test softkey	Press the Leak/Compl Test softkey
7.9.3.3	Close all flow control valves	
7.9.3.4	Using a test terminal attach a digital manometer to the 22mm bag mount connector as shown in the following illustration	Perform the on-screen instructions
7.9.3.5	Interconnect the inspiratory valve and expiratory valves with a 12-inch test hose (9995112)	
7.9.3.6	Set the APL valve to 70 cmH ₂ O and to MAN position	
7.9.3.7	Remove the ventilator hose from the breathing system and install a test cap (M33972)	
7.9.3.8	Adjust O ₂ flow to maintain 40 cmH ₂ O pressure on the digital manometer	
7.9.3.9	What is the O ₂ flow mL/min. as indicated on the display? (<100 mL/min. flow leakage)	Verify all applicable tests indicate a Pass condition
7.9.3.10	What is the pressure difference on the Paw cm H ₂ O display compared to digital manometer? (38 - 42 cmH ₂ O)	
7.9.3.11	If applicable, does the optional breathing pressure gauge agree with the readings in the previous step? (Y)	
7.9.3.12	Remove test equipment	

SV00549a

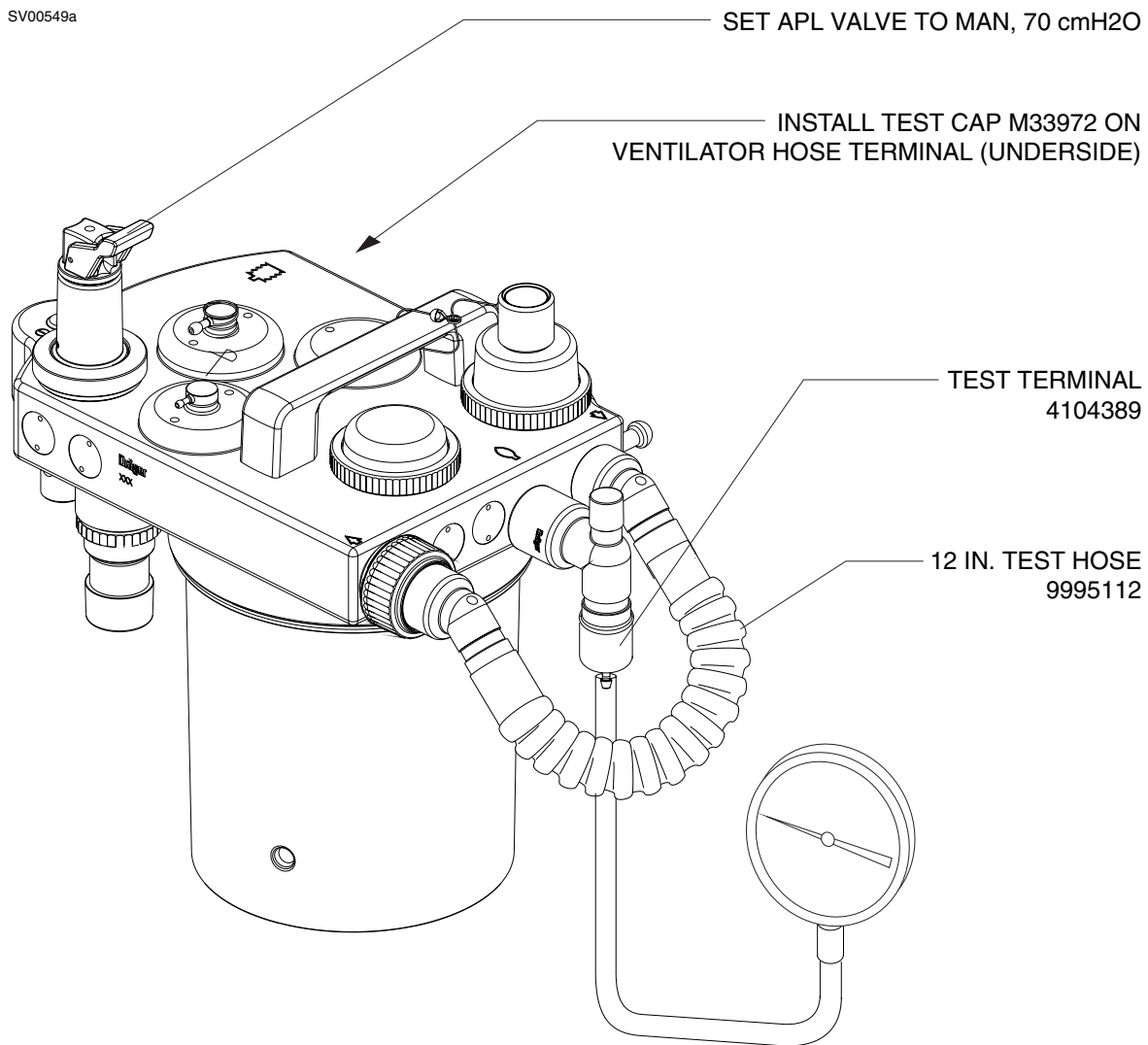

7.9.4 APL Valve Verification

7.9.4.1 Connect a digital manometer between the inspiratory and expiratory ports of the breathing system (using two test terminals and modified 4113119 fresh gas leak test device). See following illustration.

7.9.4.2 Attach a breathing bag to the bag terminal connector on the breathing system and install a test cap on the ventilator port.

SV00550b

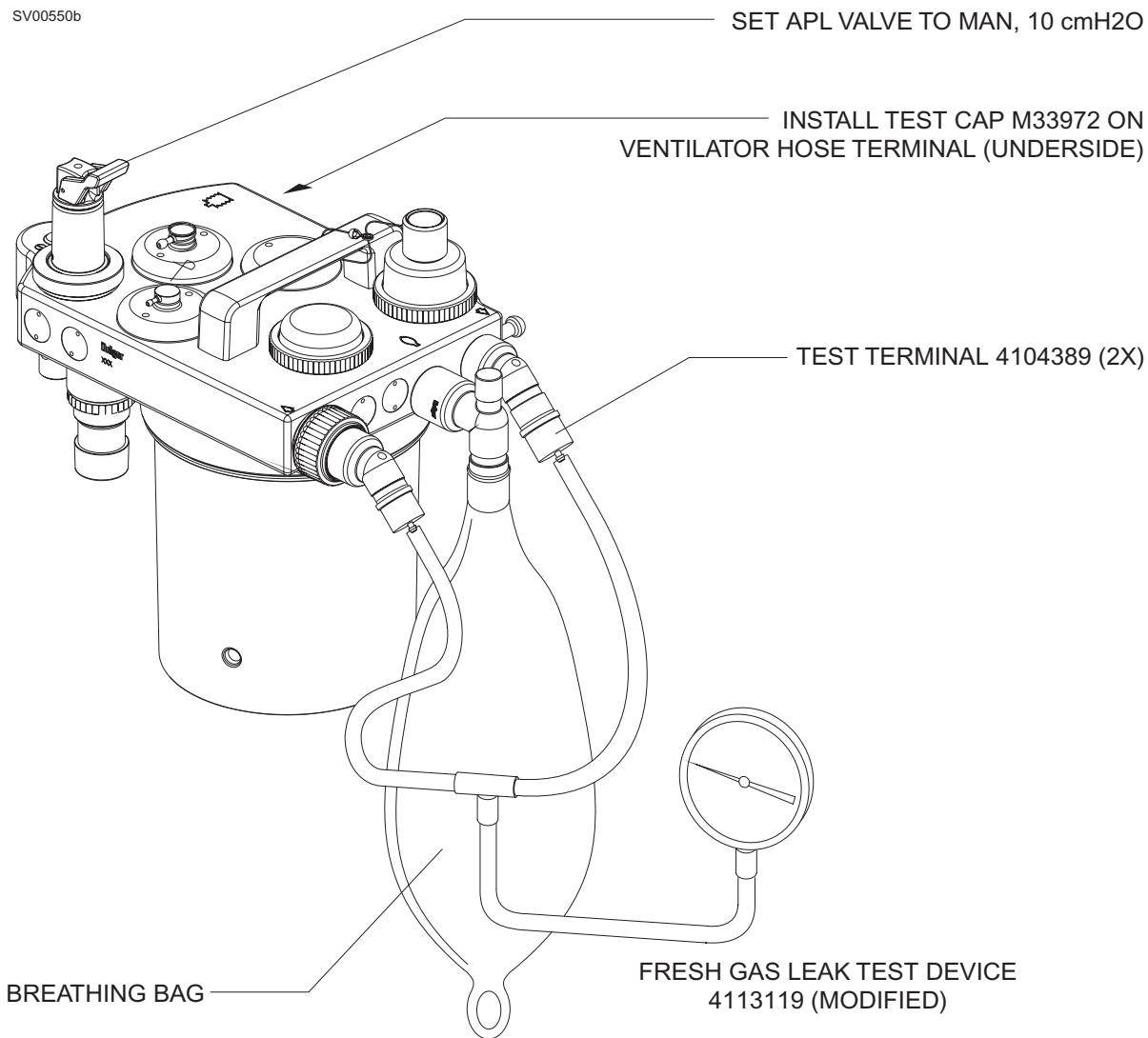

FABIUS GS	PMS PROCEDURE (continued)
------------------	----------------------------------

	Lever Style APL Valve	Rotary Knob Style APL Valve
	7.9.4.3 Verify the fresh gas hose is connected to the breathing system.	
	7.9.4.4 Verify the APL valve is in the MAN position and set to 10 cmH ₂ O.	
	7.9.4.5 Activate the flush to inflate the reservoir bag, then release.	
(✓)	7.9.4.6 Adjust the O ₂ and Air flows to 10 L/min. (20 L/min. total). Verify pressure remains between 8 and 12 cmH ₂ O.	
(✓)	7.9.4.7 Repeat Steps 7.9.4.4 thru 7.9.4.8 with the following settings, and verify APL valve accuracy:	
	Spec (cm H ₂ O)	Repeat Steps 7.9.4.4 thru 7.9.4.8 with the following settings and verify APL Valve accuracy:
APL Valve Setting	Low High	APL Valve Setting Spec (cm H ₂ O)
	Low High	Low High
30	27 33	40 34 46
50	45 55	

7.9.4.8 Close the O₂ and Air flow control valves.

7.9.4.9 Remove the digital manometer and associated test equipment from the inspiratory & expiratory valve ports and bag terminal.

7.9.5 Inhalation and Exhalation Valves

Inhalation:

7.9.5.1 Install test terminal on the 22 mm inspiratory connector.

7.9.5.2 Connect 0 - 250 cc flowmeter (S000081) with a test terminal as shown, to the ventilator port of the breathing system.

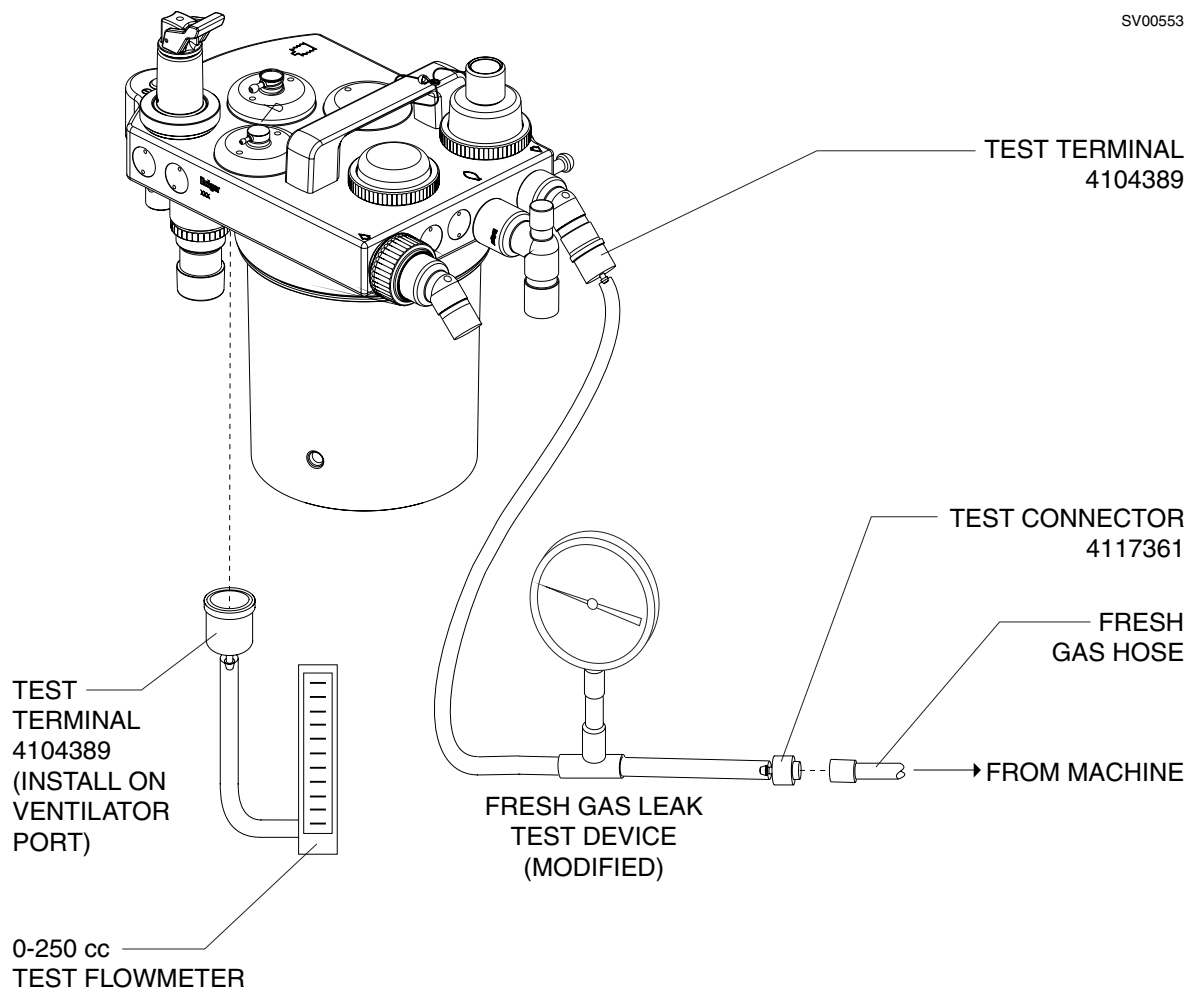

- 7.9.5.3 Remove the freshgas hose from the breathing system and connect it to the freshgas leak connector (4117163).
- 7.9.5.4 Connect the fresh gas leak connector to the fresh gas leak test device (4113119 modified) as shown.
- 7.9.5.5 Increase O₂ flow to maintain 30 cmH₂O on the digital manometer.
- (✓) 7.9.5.6 What is leakage as shown on 0 - 250 cc flowmeter? (<60 cc/min.)
- 7.9.5.7 Remove all test equipment from breathing system and disconnect digital manometer from fresh gas hose.

Exhalation:

- 7.9.5.8 Occlude ventilator and inspiratory port, each with test cap M33972.
- 7.9.5.9 Connect a digital manometer to bag mount and 0-250 cc test flowmeter to thre expiratory port as shown.
- 7.9.5.10 Connect Fresh gas hose from machine to fresh gas port of breathing system.
- 7.9.5.11 Slowly increase O2 flow to build up and maintain 30 cmH2O/ mbar on digital manometer.

NOTE: Verify pressure on digital manometer. Pressure decay is not visible on system cmH2O pressure gauge.

- (✓) 7.9.5.12 Verify leakage is <60 cc/min. as indicated on test flowmeter.
- 7.9.5.13 Remove all test equipment except for test cap on inspiratory port.

SV00563

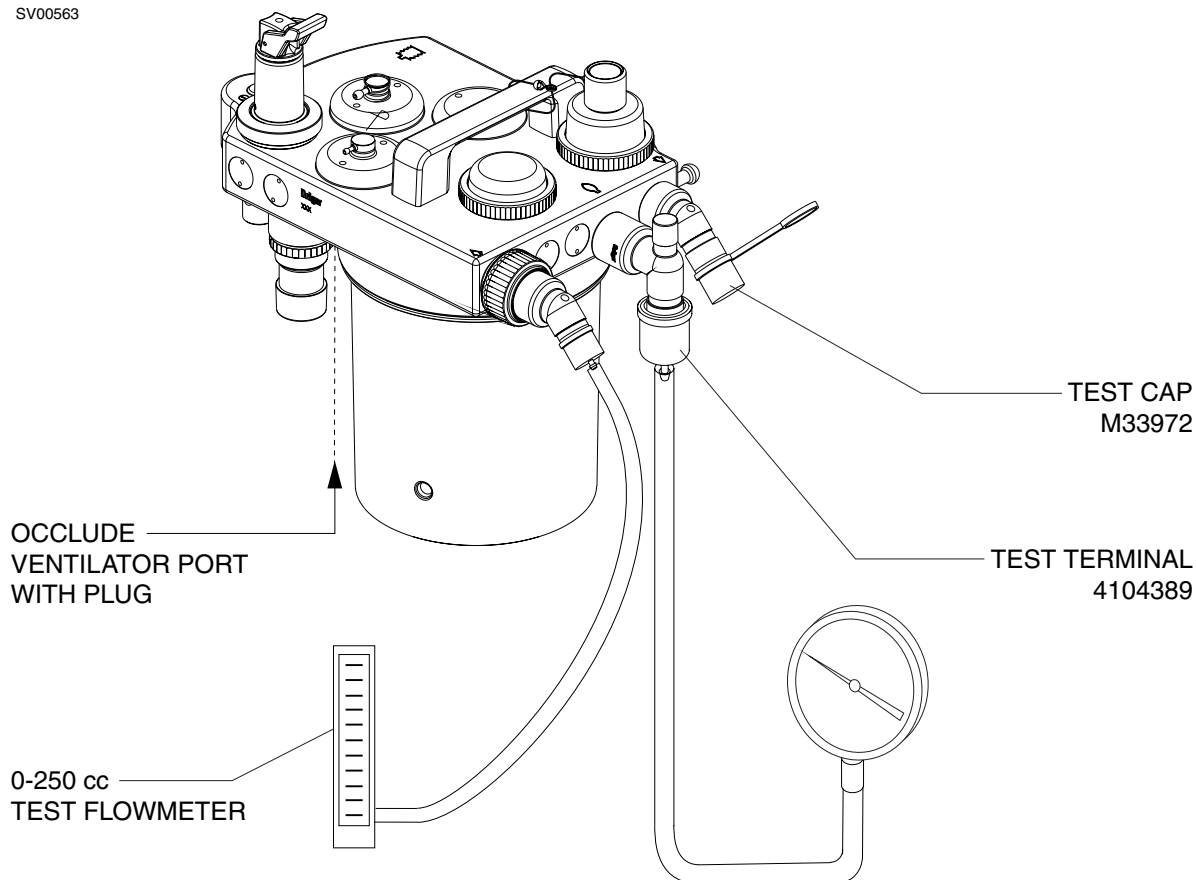

7.9.6 Reverse Flow Test (Fresh Gas Decoupling Valve)

- 7.9.6.1 Verify the breathing bag port, fresh gas connection and expiration port connections are open and not occluded.
- 7.9.6.2 Connect a digital pressure meter between the COSY pressure port and the pressure hose from the machine as shown.
- 7.9.6.3 Verify occlusion of the inspiration port with test cap M33972.
- 7.9.6.4 Connect the fresh gas hose to the ventilator port on the COSY with the test connector as shown.

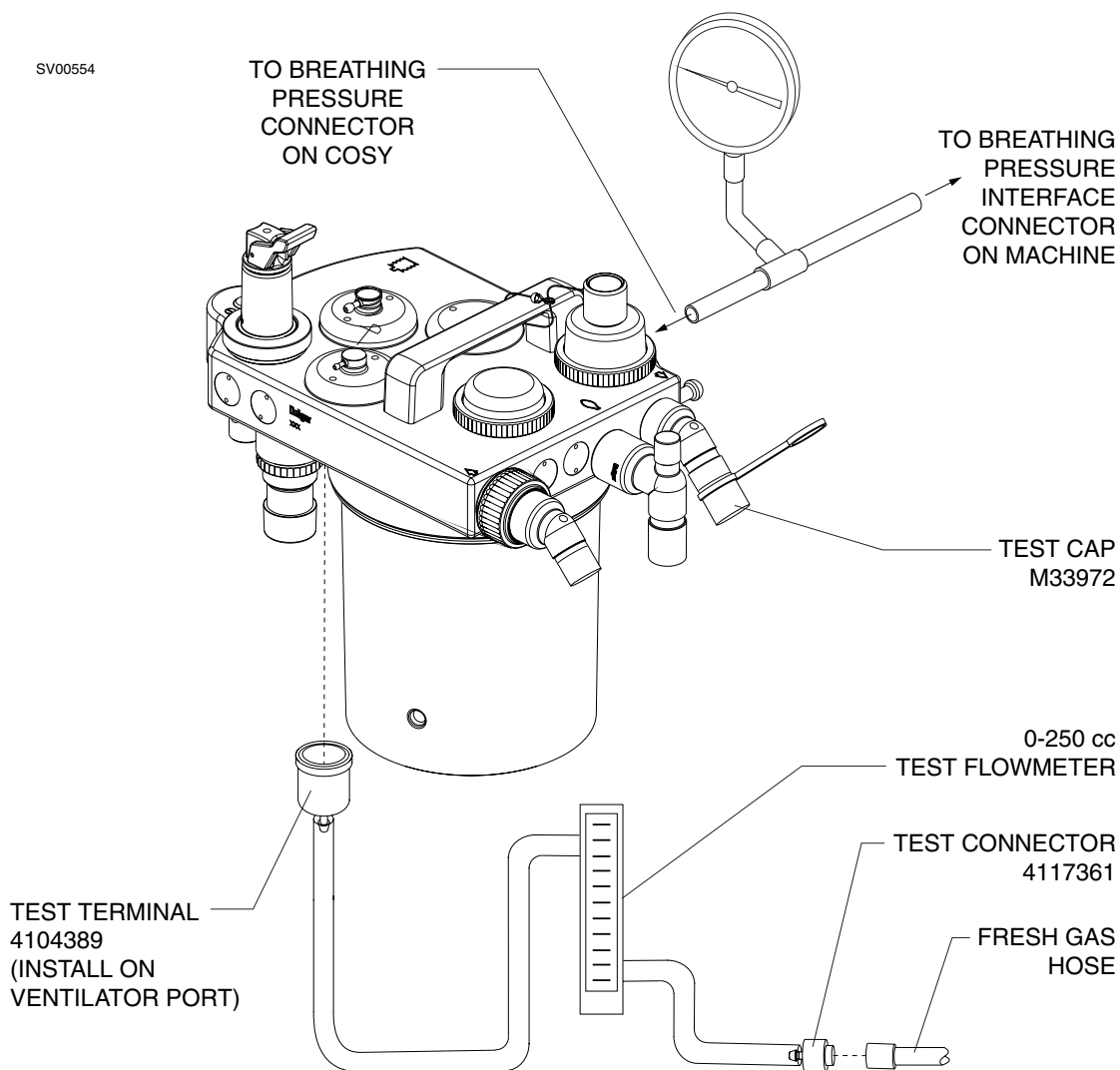

- 7.9.6.5 Verify the APL valve is in the MAN position and set to 70 cmH₂O.
- 7.9.6.6 Slowly increase O₂ flow to maintain 40 cmH₂O on the digital pressure meter.
- (✓) 7.9.6.7 Verify the flow on the 0-250 cc test flowmeter indicates less than 10 mL/min. (0.01 L/min.).
- 7.9.6.8 Close the O₂ flow control valve.
- 7.9.6.9 Remove the occlusion plugs and test equipment from the breathing system.
- 7.9.6.10 Reconnect fresh gas hose to breathing system; connect ventilator hose to vent port and breathing system.

7.9.7 Leakage Control Port

7.9.7.1 Disconnect the APL and PEEP control hoses from the interface panel at rear of machine.

7.9.7.2 Connect the PEEP control hose to the input of the 0-250 cc test flowmeter.

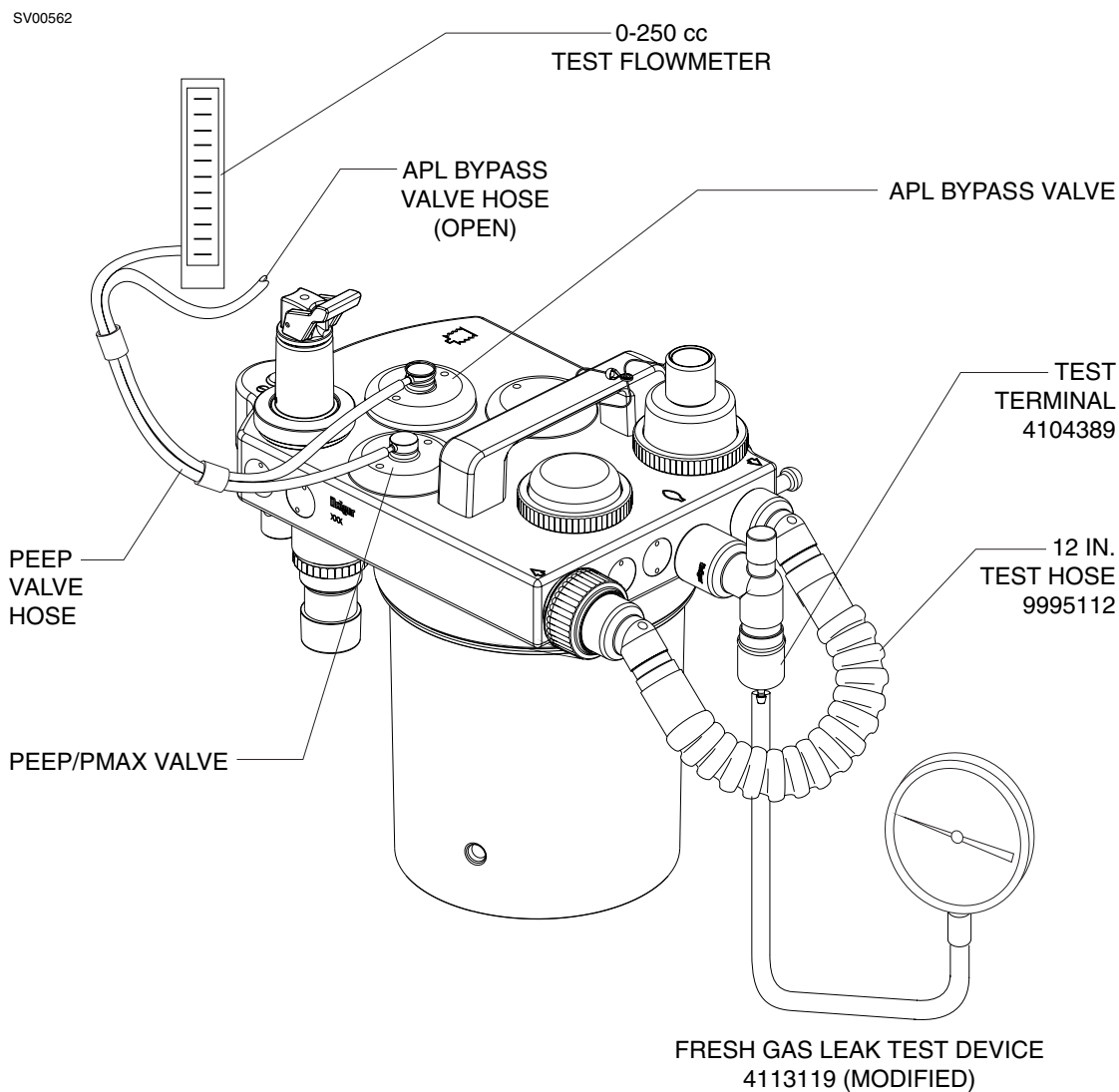

- 7.9.7.3 Short circuit the inspiratory and expiratory ports, attach a test terminal to the breathing bag port and attach a digital manometer to the test terminal.
- 7.9.7.4 Increase O₂ flow to maintain 40 cmH₂O on the digital manometer.
- (✓) 7.9.7.5 Verify the test flowmeter indicates < 10 cc/min.
- 7.9.7.6 Remove the 0-250 cc test flowmeter, digital manometer and short circuit hose from machine.
- 7.9.7.7 Return all hose connections to their normal positions.

(✓) **7.10 Vapor Interlock System**

- 7.10.1 Set all vapors to zero (0).
- 7.10.2 Adjust the handwheel on the left vapor to any concentration above zero (0).
- 7.10.3 Is it possible to adjust the right vapor? ___(N)
- 7.10.4 Adjust the handwheel on the left vapor to zero (0).
- 7.10.5 Adjust the handwheel on the right vapor to any concentration above zero (0).
- 7.10.6 Is it possible to adjust the left vapor? ___ (N).
- 7.10.7 Adjust the handwheel on the right vapor to zero (0).
- 7.10.8 If applicable, adjust handwheel of center vaporizer to any concentration above zero (0).
- 7.10.9 Is it possible to adjust the left or right vaporizer? ___(N)

7.11 Yokes & Gauges

- (✓) 7.11.1 Yokes & Check Valves (if applicable)
- 7.11.1.1 Turn the System Power switch Off.
 - 7.11.1.2 Disconnect all pipeline hoses and close all cylinder valves.
 - 7.11.1.3 Remove cylinder or yoke plug from each yoke assembly.
 - 7.11.1.4 Do all the yoke handles adjust smoothly? ___ (Y)
 - 7.11.1.5 Are the two (2) yoke pins installed securely in each yoke? ___ (Y)
 - 7.11.1.6 Is there only one (1) cylinder washer on each yoke assembly? ___ (Y)
 - 7.11.1.7 Is there a yoke plug attached to each yoke assembly? ___ (Y)
 - 7.11.1.8 Is the proper gas I.D. label affixed to each yoke assembly? ___ (Y)
 - 7.11.1.9 Attach a cylinder to each yoke assembly, open the cylinder valve, let the pressure stabilize, close the cylinder valve, and remove the cylinder from the yoke assembly.
 - 7.11.1.10 Does the yoke check valve assembly prevent the escape of excessive pressure? ___ (Y)
 - 7.11.1.11 Attach the cylinders to the yokes.

- (✓) 7.11.2 Cylinder Gauges (if applicable)
 - 7.11.2.1 Are the pressure gauges correct for the gases indicated by the flowmeters? ___ (Y)
 - 7.11.2.2 Bleed all pressure from the cylinder circuits using the flow control valves.
 - 7.11.2.3 Are the cylinder gauges at zero (0) PSI? ___ (Y)
 - 7.11.2.4 Open the cylinder valves.
 - 7.11.2.5 Do the cylinder pressure gauges respond properly? ___ (Y)

7.12 Gas Inlet Regulator Output

7.12.1 O₂ Inlet Regulator

7.12.1.1 Bleed all cylinder and pipeline pressures. Disconnect all cylinders and pipeline hoses and remove rear panel to access gas inlet assembly.

7.12.1.2 Remove the pneumatic hose from the O₂ outlet of the gas inlet block and interconnect a digital manometer as shown.

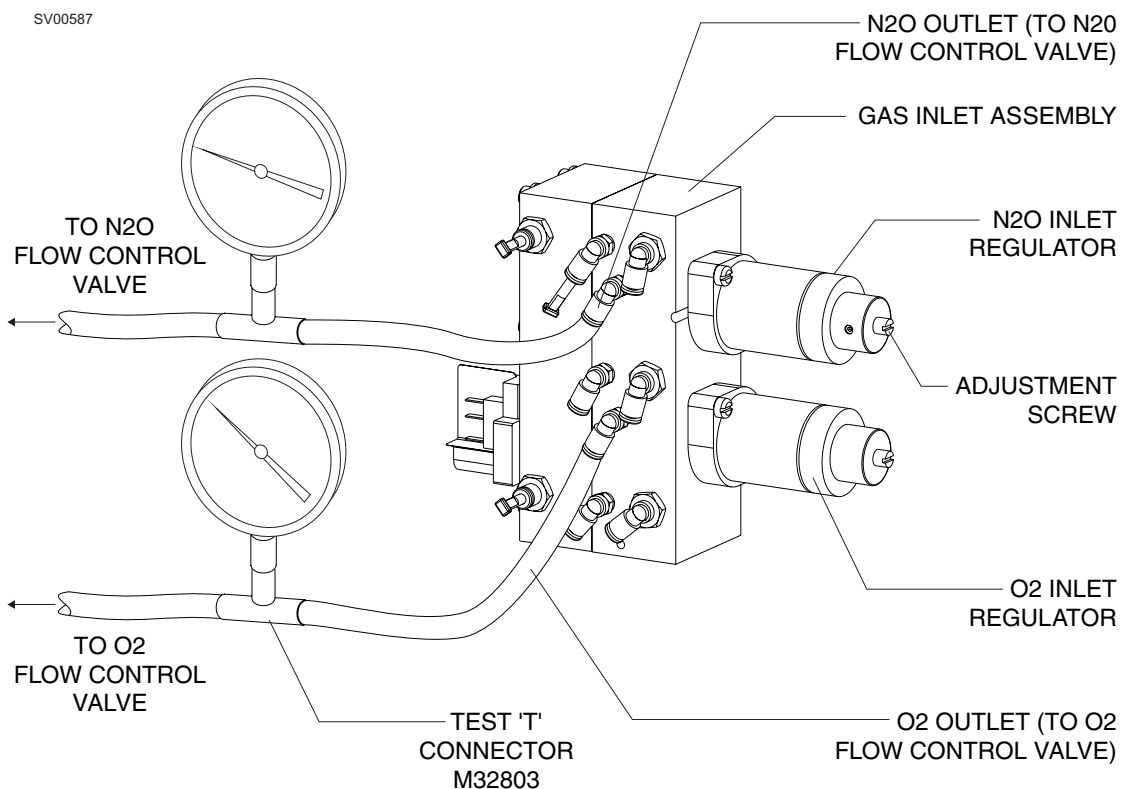

7.12.1.3 Reconnect the O₂ pipeline hose to the O₂ pipeline inlet connector and pressurize the O₂ supply.

7.12.1.4 Set the O₂ flow to 4 L/min.

- (✓) 7.12.1.5 After the digital manometer stabilizes, what is the regulator output pressure? ___psi (28 - 32 psi)
- 7.12.1.6 Deplete O₂ pressure from the pipeline supply.
- 7.12.1.7 Close the flow control valve and disconnect the O₂ pipeline hose from the inlet.
- 7.12.1.8 Remove test equipment and reconnect the O₂ pneumatic hose leading from the O₂ flow control valve to the O₂ connector on the inlet block.
- 7.12.2 N₂O Inlet Regulator
 - 7.12.2.1 Disconnect the N₂O pneumatic hose from the outlet connector on the gas inlet block that connects to the N₂O flow control valve.
 - 7.12.2.2 Interconnect a digital manometer between the N₂O outlet connector and the hose removed in the previous step. See illustration on previous page.
 - 7.12.2.3 Reconnect the O₂ and N₂O pipeline hoses to the inlet block and activate the pipeline supplies.
 - (✓) 7.12.2.4 Set the O₂ and N₂O flows to 4 L/min. After the digital manometer stabilizes, what is the N₂O regulator output pressure? ___psi (28 - 32 psi)
 - 7.12.2.5 Deplete the O₂ and N₂O pipeline pressures.
 - 7.12.2.6 Close the O₂ and N₂O flow control valves and disconnect both pipeline hoses from the inlet block.
 - 7.12.2.7 Remove test equipment and reconnect the N₂O hose from the flow control valve to the N₂O outlet on the inlet block.

7.12.3 Pipeline Check Valves

O2 Pipeline Check Valve:

- 7.12.3.1 Attach a Swagelock fitting (P/N 4109318) to the inlet of the S000081 test flowmeter.
- 7.12.3.2 Detach the hose from the Pressure Test adapter (P/N 4114807) gauge assembly and attach it to the inlet of the test flowmeter as shown.
- 7.12.3.3 Attach the appropriate O2 adapter to the O2 connector on the inlet block, and connect the other end of the hose with the quick disconnect fitting to the adapter as shown.

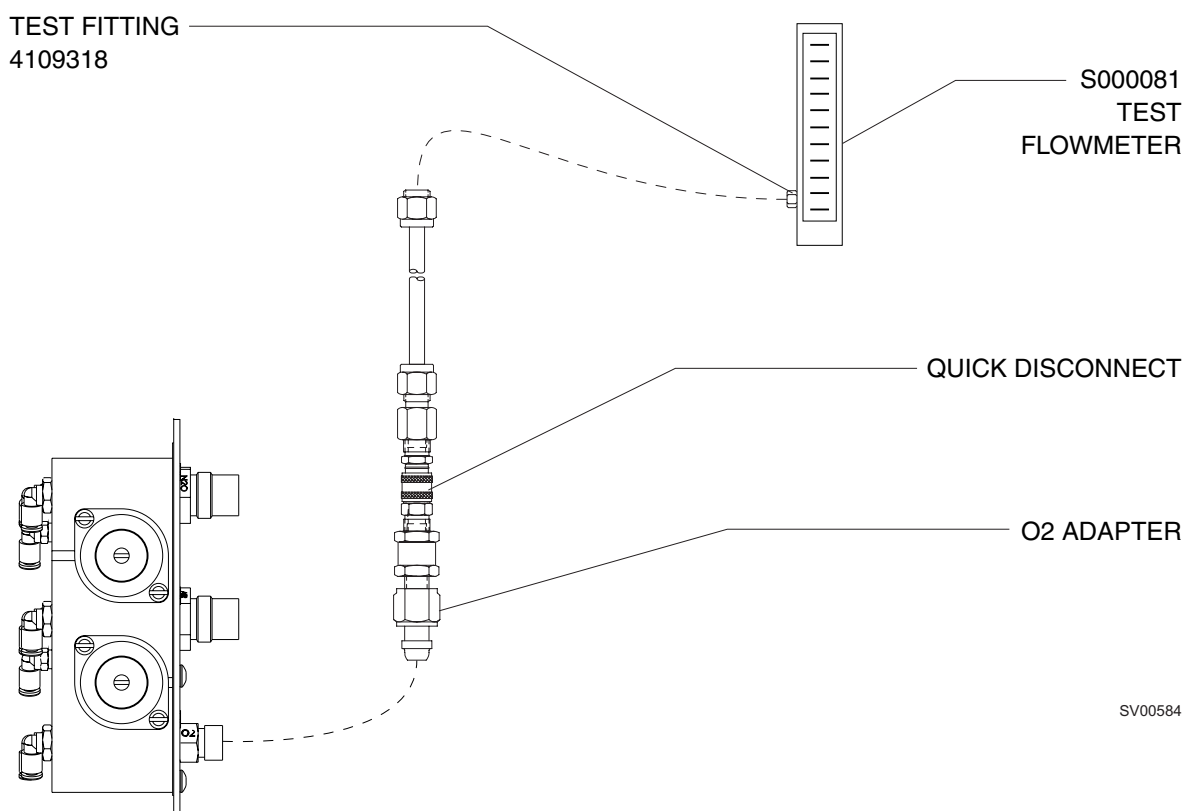

(✓)

- 7.12.3.4 Open an O2 (reserve) cylinder valve. What is the flow as indicated on the test flowmeter? ___cc ≤5 cc/min.

N2O Pipeline Check Valve (if applicable)

7.12.3.5 Attach the appropriate N2O adapter to the N2O connector on the inlet block, and transfer the end of the hose with the quick disconnect fitting to the N2O adapter.

(✓) 7.12.3.6 Open the N2O (reserve) cylinder. What is the flow as indicated on the test flowmeter? ___cc \leq 5 cc/min.

Air Pipeline Check Valve (if applicable)

7.12.3.7 Attach the appropriate Air adapter to the Air connector on the inlet block, and transfer the end of the hose with the quick disconnect fitting to the Air adapter.

(✓) 7.12.3.8 Open the Air (reserve) cylinder. What is the flow as indicated on the test flowmeter? ___cc \leq 5 cc/min.

7.12.3.9 Remove all test equipment and reinstall the gas inlet block and back panel on the machine.

7.13 Cylinder Regulator & Pipeline Gauges

Minimum cylinder pressure requirements for this test are: N2O: 600 psi;
O2, Air: 1000 psi.

(✓) 7.13.1 N2O Cylinder Regulator (if applicable)

7.13.1.1 Configure test gauge 4114807 using the appropriate adapters between the pipeline inlet of machine and central supply hose. A typical test connection is shown below (O2 illustrated).

SV00465

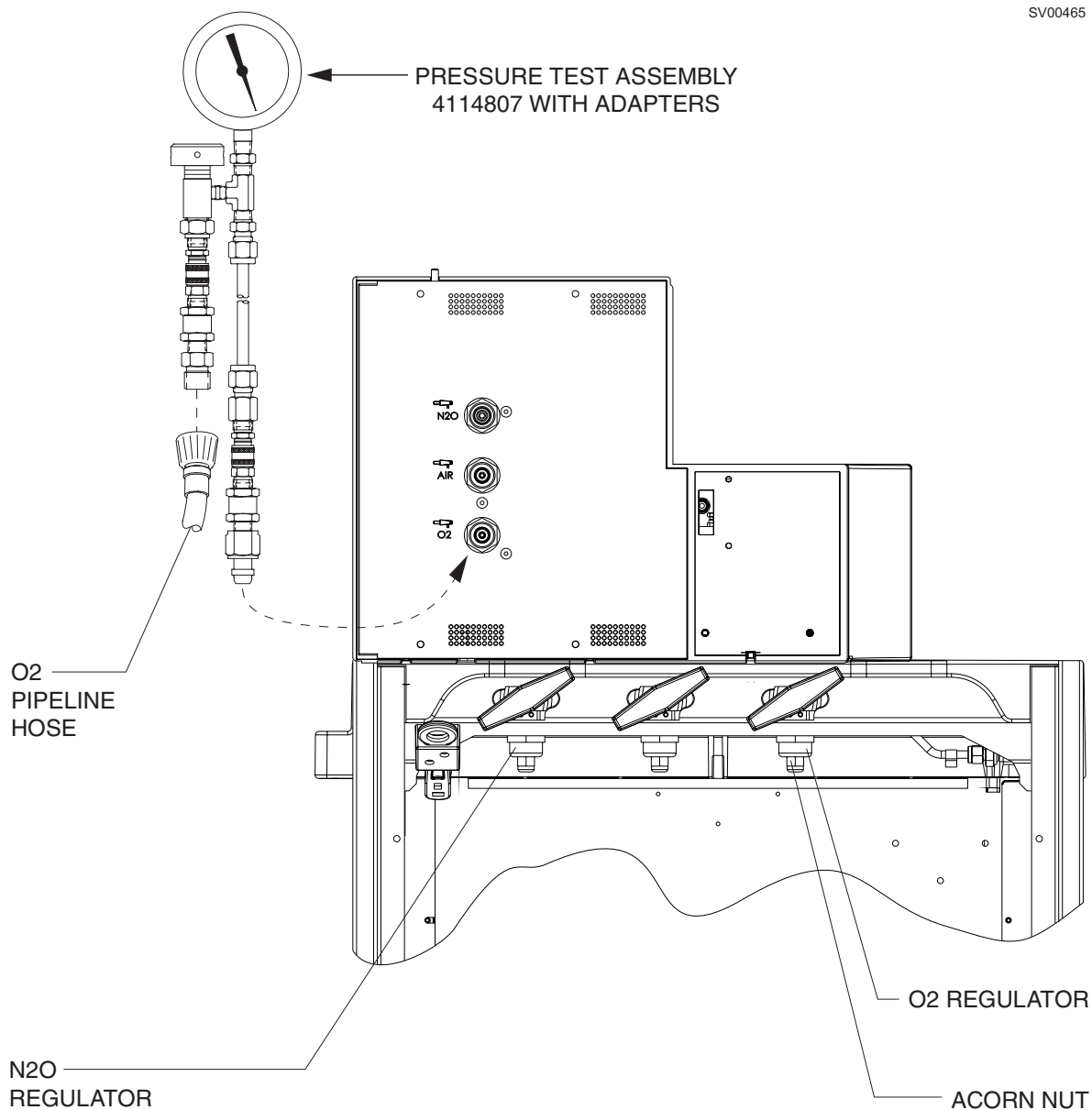

- 7.13.1.2 Connect the test fixture hose to the machine's nitrous oxide pipeline inlet.
- 7.13.1.3 Does the back panel correctly identify the nitrous oxide inlet? ___(Y)
- 7.13.1.4 Connect the nitrous oxide pipeline supply hose to the test fixture.
- 7.13.1.5 Open the nitrous oxide and the oxygen cylinder valves.
- 7.13.1.6 Set the oxygen and nitrous oxide flows to 4 L/min.
- 7.13.1.7 Depress the push button on the test device.
- (✓) 7.13.1.8 Release the push button. After the pressure decay stabilizes, what is the regulator output pressure? ___psi (32 - 40)
NOTE: f a pressure decrease does not occur, either the hospital's supply pressure is too low or the regulator pressure is set too high.
- (✓) 7.13.2 N₂O Pipeline Gauge Accuracy
 - 7.13.2.1 Close the nitrous oxide cylinder valve and drain all nitrous oxide pressure.
 - 7.13.2.2 Depress and hold the push button on the test device.
 - 7.13.2.3 Does the nitrous oxide gauge respond properly? ___(Y)
 - (✓) 7.13.2.4 After the pressure stabilizes, are the indicated pressures on the test gauge and the nitrous oxide pipeline pressure gauge within the normal operating range? 41 - 87 psi (non-USA), 50 - 55 psi (USA).

7.13.3 N₂O Pipeline Leak

7.13.3.1 Close the nitrous oxide flow control valve.

7.13.3.2 Release the test device push button.

(✓) 7.13.3.3 After 30 seconds, what is the pressure loss? ___psi (<5)

7.13.3.4 Remove the test equipment and reconnect the nitrous oxide pipeline hose.

(✓) 7.13.4 Air Cylinder Regulator

7.13.4.1 Configure the test gauge using the appropriate adapters between the pipeline inlet of machine and central supply hose.

7.13.4.2 Connect the test fixture hose to the machine's air pipeline inlet.

7.13.4.3 Does the back panel correctly identify the air inlet? ___(Y)

7.13.4.4 Connect the air pipeline supply hose to the test fixture.

7.13.4.5 Set the air flow to 4 L/min.

7.13.4.6 Depress the push button on the test device.

(✓) 7.13.4.7 Release the push button. After the pressure decay stabilizes, what is the regulator output pressure? ___psi (based upon cylinder pressure as given in the following table)

Cylinder Pressure (psi)	Compensated Regulator output tolerances (-4/+2)
2000	27 - 33 (*30 - 36)
1800	28 - 34 (*31 - 37)
1600	29 - 35 (*32 - 38)
1400	30 - 36 (*33 - 39)
1200	31 - 37 (*34 - 40)
1000	32 - 38 (*35 - 41)

* Canada settings

NOTE: If a pressure decrease does not occur, either the hospital's supply pressure is too low or the regulator pressure is set too high.

- (✓) 7.13.5 Air Pipeline Gauge Accuracy
 - 7.13.5.1 Close the air cylinder valve and drain all air pressure.
 - 7.13.5.2 Depress the push button on the test device.
 - 7.13.5.3 Does the air gauge respond properly? ___(Y)
 - 7.13.5.4 After the pressure stabilizes, are the indicated pressures on the test gauge and the air pressure gauge within the normal operating range? 41 - 87 psi (non-USA), 50 - 55 psi (USA).
- 7.13.6 Air Pipeline Leak
 - 7.13.6.1 Close the air flow control valve
 - 7.13.6.2 Release the test device push button
 - (✓) 7.13.6.3 After thirty (30) seconds, what is the pressure loss? ___psi (<5)
 - 7.13.6.4 Remove the test equipment and reconnect the air pipeline hose.
- (✓) 7.13.7 O₂ Cylinder Regulator
 - 7.13.7.1 Configure a test gauge 4114807 using the appropriate adapters between the pipeline inlet of machine and central supply hose.
 - 7.13.7.2 Connect the test fixture hose to the machine's oxygen pipeline inlet.
 - 7.13.7.3 Connect the oxygen pipeline supply hose to the test fixture.
 - 7.13.7.4 Does the back panel correctly identify the oxygen inlet? ___(Y)
 - 7.13.7.5 Set the oxygen flow to 4 L/min.
 - 7.13.7.6 Depress the push button on the test device.

- (✓) 7.13.7.7 Release the push button. After the pressure decay stabilizes, what is the regulator output pressure? ___psi (based upon cylinder pressure as given in the following table)

Cylinder Pressure (psi)	Compensated Regulator output tolerances (-4/+2)
2000	27 - 33 (*30 - 36)
1800	28 - 34 (*31 - 37)
1600	29 - 35 (*32 - 38)
1400	30 - 36 (*33 - 39)
1200	31 - 37 (*34 - 40)
1000	32 - 38 (*35 - 41)

* Canada settings

NOTE: If a pressure decrease does not occur, either the hospital's supply pressure is too low or the regulator pressure is set too high.

- (✓) 7.13.8 O₂ Pipeline Gauge Accuracy
- 7.13.8.1 Close the oxygen cylinder valve and drain all oxygen pressure.
- 7.13.8.2 Depress the push button on the test device.
- 7.13.8.3 Does the oxygen gauge respond properly? ___(Y)
- 7.13.8.4 After the pressure stabilizes, are the indicated pressures in the test gauge and the oxygen pressure gauge within the normal operating range? 41 - 87 psi (non-USA), 50 - 55 psi (USA).
- 7.13.9 O₂ Pipeline Leak
- 7.13.9.1 Release the test device push button
- (✓) 7.13.9.2 After thirty (30) seconds, what is the pressure loss? ___psi (<5)

7.14 High Pressure Leak

7.14.1 Oxygen High Pressure Leak

7.14.1.1 Verify the System Power switch is OFF.

7.14.1.2 Open the oxygen cylinder valve.

7.14.1.3 Let the pressure stabilize.

7.14.1.4 Close the oxygen cylinder valve and remove the cylinder.

7.14.1.5 Observe the oxygen cylinder pressure gauge.

(✓) 7.14.1.6 After two (2) minutes, what is the pressure loss? ___ PSI (<50)

7.14.1.7 Attach the cylinder.

7.14.2 Nitrous Oxide High Pressure Leak (if applicable)

7.14.2.1 Turn the System Power switch to ON.

7.14.2.2 Open one (1) oxygen cylinder valve and one (1) nitrous oxide cylinder valve.

7.14.2.3 Adjust the oxygen flow to 4 L/min.

7.14.2.4 Let the pressure stabilize.

7.14.2.5 Close the nitrous oxide cylinder valve and remove the cylinder.

7.14.2.6 Observe the nitrous oxide cylinder pressure gauge.

(✓) 7.14.2.7 After two (2) minutes, what is the pressure loss? ___ PSI (<50)

7.14.2.8 Attach the cylinder.

7.14.2.9 Close the oxygen flow control valve.

7.14.3 Air High Pressure Leak

7.14.3.1 Turn the System Power switch to ON.

7.14.3.2 Open one (1) oxygen cylinder valve and the air cylinder valve.

7.14.3.3 Adjust the oxygen flow to 4 L/min.

7.14.3.4 Let the pressure stabilize.

7.14.3.5 Close the air cylinder valve and remove the cylinder.

7.14.3.6 Observe the air cylinder pressure gauge.

(✓) 7.14.3.7 After two (2) minutes, what is the pressure loss? ___ PSI (<50)

7.14.3.8 Attach the cylinder.

7.14.3.9 Close the oxygen flow control valve.

7.15 Oxygen Supply Failure Protection

- (✓) 7.15.1 Nitrous Oxide (if applicable)
- 7.15.1.1 Open and close the oxygen cylinder valve.
 - 7.15.1.2 Open the nitrous oxide cylinder valve.
 - 7.15.1.3 Set the O₂ and N₂O flows to 4 L/min.
 - 7.15.1.4 Does the flow of nitrous oxide cease when the oxygen flow is depleted? ___ (Y)
 - 7.15.1.5 Connect the O₂ pipeline supply.
 - 7.15.1.6 Close the nitrous oxide cylinder valve and bleed the pressure from the circuit.
 - 7.15.1.7 Connect the N₂O pipeline supply.
 - 7.15.1.8 Disconnect the O₂ pipeline supply.
 - 7.15.1.9 Does the flow of nitrous oxide cease when the oxygen pressure is depleted? ___ (Y)
 - 7.15.1.10 Close the nitrous oxide flow control valve.
 - 7.15.1.11 Disconnect the N₂O pipeline supply.

7.15.2 Oxygen Supply Pressure Alarm

- 7.15.2.1 If not already connected, connect the Pressure Test Assembly (P/N 4114807) with O₂ adapters between the central supply hose and the machine.
- 7.15.2.2 Open and close an oxygen cylinder.
- 7.15.2.3 Set the oxygen flow to 0.5 L/min.
- 7.15.2.4 Depress and release the test device push button.
- (✓) 7.15.2.5 What is the pressure on the test gauge when the "O₂ SUPPLY LOW !!!" message and associated red indicator appear? ___ PSI (16 - 24)
- (✓) 7.15.2.6 Does the "O₂ SUPPLY LOW !!!" message appear on the display? ___ (Y)
- 7.15.2.7 Bleed the remaining O₂ pressure from the system, then close the flow control valve.
- 7.15.2.8 Remove the test gauge from the machine and reconnect the pipeline supply hose.

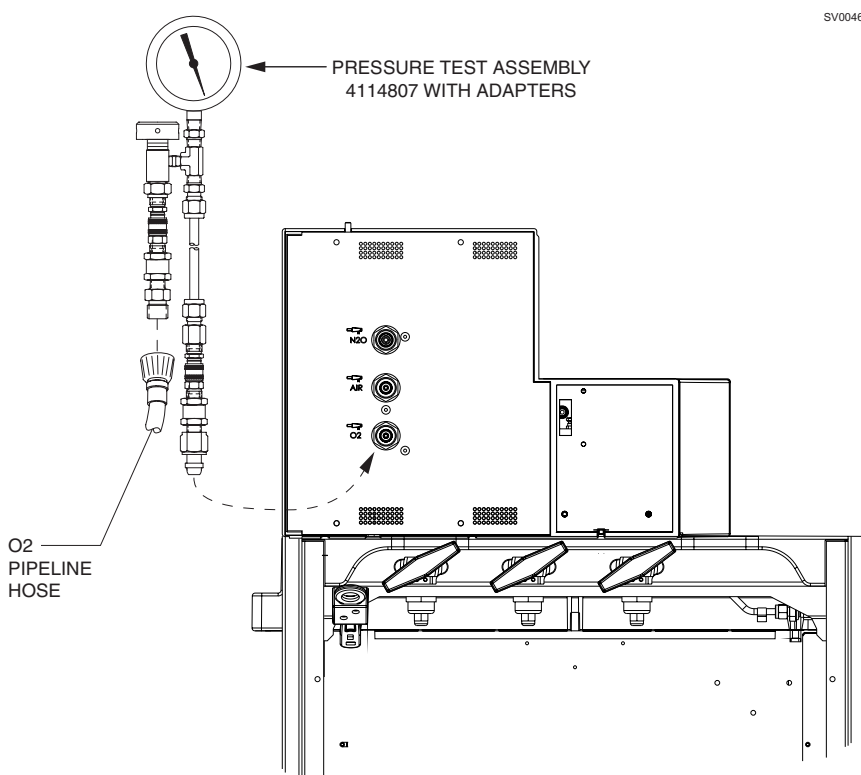

7.16 Flowmeters

- (✓) 7.16.1 Oxygen Flowmeter
 - 7.16.1.1 Open the O₂ cylinder valve.
 - 7.16.1.2 Is it possible to adjust the flow of oxygen to 10 L/min.? ___ (Y)
 - 7.16.1.3 Close the O₂ cylinder valve and bleed the pressure.
 - 7.16.1.4 Connect the O₂ pipeline supply, and verify the operation of the oxygen flowmeter.
 - 7.16.1.5 Is the correct flow control knob and label attached to the oxygen flow control valve? ___ (Y)
 - 7.16.1.6 Close the oxygen flow control valve.

- (✓) 7.16.2 Nitrous Oxide Flowmeter (if applicable)
 - 7.16.2.1 Set the oxygen flow to 4 L/min.
 - 7.16.2.2 Open the nitrous oxide cylinder valve.
 - 7.16.2.3 Is it possible to adjust the flow of nitrous oxide to 10 L/min.? ___ (Y)
 - 7.16.2.4 Close the nitrous oxide cylinder valve and bleed the pressure.
 - 7.16.2.5 Connect the N₂O pipeline supply, and verify the proper operation of the N₂O flow.
 - 7.16.2.6 Is the correct flow control knob attached to the N₂O flow control valve? ___ (Y)
 - 7.16.2.7 Close the oxygen and nitrous oxide flow control valves.

- (✓) 7.16.3 Air Flowmeter
 - 7.16.3.1 Connect the Air pipeline supply (if applicable).
 - 7.16.3.2 Is it possible to adjust the flow of air to 10 L/min.? ___ (Y)
 - 7.16.3.3 Close the air flow control valve and disconnect the Air pipeline supply.
 - 7.16.3.4 Is the correct flow control knob attached to the air flow control valve? ___ (Y)

- (✓) 7.16.4 Auxiliary Oxygen Flowmeter (if applicable)
 - 7.16.4.1 Verify the auxiliary oxygen flowmeter flow control valve is closed.
 - 7.16.4.2 Connect a pressure manometer to the Aux O2 outlet.
 - 7.16.4.3 Is there an increase in pressure? ___ (N)
 - 7.16.4.4 Slowly open the Aux O2 flow control valve to apply a pressure of 50 cm H₂O to the manometer, then close control valve and start timer.

- (✓) 7.16.4.5 After 30 seconds, what is the pressure on the manometer? ___ (40 - 50 cm H₂O)
 - 7.16.4.6 Remove the manometer test fixture from the outlet.
 - 7.16.4.7 Is it possible to adjust the flow over the full range of the auxiliary oxygen flowmeter? ___ (Y)
 - 7.16.4.8 Set the flow rate to 5 L/min.
 - 7.16.4.9 Hold the calibrated oxygen sensor at the auxiliary oxygen flowmeter outlet.

- (✓) 7.16.4.10 After the value stabilizes, what is the oxygen concentration? ___ % (97-100)
 - 7.16.4.11 Remove the oxygen sensor from the auxiliary oxygen flowmeter, and insert it into the inspiratory valve dome adapter.
 - 7.16.4.12 Close the auxiliary oxygen flow control valve.

(✓) 7.17 Oxygen Monitor

- 7.17.1 Press the Man Spont key and press the rotary knob to confirm.
- 7.17.2 Verify the ventilator hose is connected to the breathing system.
- 7.17.3 Disconnect the oxygen sensor cable from the Oxygen Sensor interface.
- 7.17.4 The following message shall appear on the display: O2 Sensor Fail!.
- 7.17.5 Reconnect the oxygen sensor.

NOTE: Make sure that the sensor has stabilized in ambient air for several minutes.

- 7.17.6 Press the Setup key, then perform O2 calibration per on-screen instructions.
- 7.17.7 After calibration is completed, verify the “O2 Sensor Fail” message disappears.
- 7.17.8 What is the oxygen concentration? ___ % (21)
- 7.17.9 What is the low oxygen alarm default? ___ % (20)
- 7.17.10 Press the  key and select the OXYGEN LOW alarm limit. Does the low alarm limit illuminate? ___ (Y)
- 7.17.11 Verify that the low alarm limit has a range from 18 to 99%. Adjust the alarm limit above current O2 monitor value.

(✓) 7.17.12 INSP O2 LOW !!! shall appear on the display and the heading shall be flashing with a corresponding audible alarm.

- 7.17.13 Place the oxygen sensor into the inspiratory valve dome adapter and set the APL valve to 70 and MAN position. Attach a 12-inch hose to the inspiratory port and occlude the bag mount.
- 7.17.14 Set the oxygen flow to 4 L/min.
- 7.17.15 Verify that the INSP O2 LOW !!! message has cleared.
- 7.17.16 Select the OXYGEN HIGH alarm limit. Does the high alarm limit illuminate? ___ (Y)
- 7.17.17 What is the high oxygen alarm default? ___ % (100)

- 7.17.18 Verify that the high alarm limit has a range from 100 to 19%.
- 7.17.19 Set the high alarm limit to below the correct O2 reading.
- (✓) 7.17.20 Does the message INSP O2 HIGH !! appear on the display? ___ (Y)
- 7.17.21 Return the high alarm limit to 100 and confirm.
- 7.17.22 The INSP O2 HIGH message shall disappear.
- (✓) 7.17.23 Within 3 minutes, what is the oxygen concentration? ___ % (97-100)

7.18 Oxygen Concentrations

- (✓) 7.18.1 Oxygen + Nitrous Oxide Concentration (if applicable)
 - 7.18.1.1 Verify the oxygen flow is at 4 L/min.
 - 7.18.1.2 Depress the O₂ Flush button for 5 seconds.
 - 7.18.1.3 Does the oxygen monitor read 97-100% after the value stabilizes?__ (Y)
 - 7.18.1.4 Set the nitrous oxide flow to 2 L/min.
- (✓) 7.18.1.5 After the value stabilizes on the oxygen sensor, what is the O₂ concentration? ___ % (62-72)
 - 7.18.1.6 If measured value is within the range, close the N₂O flow control valve and proceed to Section 7.18.2.
 - 7.18.1.7 If measured value is not within range, close the nitrous oxide flow control valve and adjust the oxygen flow until total flow meter reads 4 L/min. What is the corresponding display flow rate? ___ L/min (3.9 - 4.7)
- (✓) 7.18.1.8 Set nitrous oxide flow to 2.5 L/min and oxygen flow to 2.5 L/min on the displays. What is the corresponding flow visually approximated on the total flow meter? ___ L/min (4.5 - 5.5)
 - 7.18.1.9 Close the nitrous oxide flow control valve.
- (✓) 7.18.2 Oxygen + Air Concentration
 - 7.18.2.1 Depress the O₂FLUSH button for 5 seconds.
 - 7.18.2.2 Does the oxygen monitor read 97-100% after the value stabilizes?__ (Y)
 - 7.18.2.3 Set the air flow to 2 L/min.
- (✓) 7.18.2.4 After the value stabilizes, what is the O₂ concentration? ___%(71-77)
 - 7.18.2.5 Close the air and O₂ flow control valves.

7.19 SORC

- 7.19.1 Depress the O₂FLUSH for 5 seconds.
- 7.19.2 Set the O₂ and N₂O flow to 10 L/min.
- 7.19.3 Set the O₂ flow control valve to 0.8 L/min.
- (✓) 7.19.4 What is the oxygen concentration after the value stabilizes? ___ %
(≥23%)
- 7.19.5 Adjust the oxygen flow to 1.5 L/min.
- (✓) 7.19.6 What is the oxygen concentration after the value stabilizes? ___ %
(≥23%)
- 7.19.7 Adjust the oxygen flow to 2 L/min.
- (✓) 7.19.8 What is the oxygen concentration after the value stabilizes? ___ %
(≥23%)
- 7.19.9 Adjust the oxygen flow to achieve 10 L/min. N₂O.
- (✓) 7.19.10 What is the oxygen concentration after the value stabilizes? ___ %
(≥23%)
- (✓) 7.19.11 Reduce the O₂ flow to 0.5 L/min. Verify that the N₂O flow is greater than or equal to 0.6 L/min. ___ L/min.
- 7.19.12 Reduce O₂ flow to zero, then slowly increase O₂ flow until N₂O flow is present.
- (✓) 7.19.13 What is O₂ flow when N₂O starts to flow (0.1 - 0.2 L/min.)
- 7.19.14 Close the O₂ and N₂O flow control valves.

(✓) **7.20 Pressure Monitor**

- 7.20.1 Verify unit is in Man Spont mode.
- 7.20.2 Disconnect the breathing pressure sensor line from the breathing system.
- 7.20.3 Connect a test pressure gauge and syringe to the breathing pressure sensor line.
- 7.20.4 Press the "Alarms" key.
- 7.20.5 What is the pressure apnea threshold default? ___ cm H₂O (8)
- 7.20.6 Verify that the pressure apnea threshold limit has a range from 5 to 30 cm H₂O.
- 7.20.7 Adjust the threshold limit to 10 cm H₂O.
- 7.20.8 Select the HIGH alarm limit, and confirm.
- 7.20.9 What is the high alarm limit default? ___ cm H₂O (40)
- 7.20.10 Verify that the high alarm limit has a range from 10 to 70 cm H₂O.
- 7.20.11 Set the high alarm limit to 40 cm H₂O, and confirm. Set the ventilator to Volume Control mode and confirm.
- 7.20.12 Increase the pressure to 25 cm H₂O, then decrease the pressure to 0 cm H₂O and start a stop watch.
- (✓) 7.20.13 What is the time when APNEA PRESSURE !! appears as a medium alarm tone with associated flashing yellow LED? ___ sec (26-34)
- (✓) 7.20.14 What is the time when the APNEA PRESSURE !!! appears as a high alarm with flashing red LED and corresponding audible alarms? ___ sec (56-64)

NOTE: For software version >1.20, with threshold low alarm enabled a corresponding threshold low alarm shall appear.

- 7.20.15 After the APNEA PRESSURE !!! alarm is displayed as a high, slowly increase the test pressure.

- (✓) 7.20.16 At what pressure does the APNEA PRESSURE alarm deactivate? ___ cm H₂O (7-13)
 - 7.20.17 Adjust the threshold to 18 cm H₂O.
 - 7.20.18 Increase the pressure to 20 cm H₂O, maintain the pressure, and start a stopwatch.
- (✓) 7.20.19 What is the time when CONTINUOUS PRESSURE appears as a high alarm? ___ sec (12-18)
- (✓) 7.20.20 Decreasing the pressure slowly, what is the pressure at which the CONTINUOUS PRESSURE alarm deactivates? ___ cm H₂O (15-21)
 - 7.20.21 Increase the test pressure.
- (✓) 7.20.22 At what pressure does the Airway Pressure High !!! alarm activate? ___ cm H₂O (38-42)
 - 7.20.23 Bleed the pressure.
 - 7.20.24 Using a syringe in place of the squeeze bulb, slowly create a sub-atmospheric pressure.
- (✓) 7.20.25 At what pressure does the Pressure Negative !!! alarm activate? ___ cm H₂O (-2 to -8)
 - 7.20.26 Return the pressure to zero.
 - 7.20.27 Does the PRESSURE NEGATIVE alarm deactivate? ___(Y)
 - 7.20.28 Using the syringe, increase the pressure to 20 cmH₂O; then decrease the pressure to zero.
 - 7.20.29 Press the Autoset soft key.
 - 7.20.30 Does the threshold limit adjust to within four (4) cmH₂O of peak pressure? ___ (Y)
 - 7.20.31 Press the Man Spont key and confirm.
 - 7.20.32 Reconnect the breathing pressure sensor line to the breathing system.

7.21 Ventilator

- (✓) 7.21.1 Manual Ventilation
 - 7.21.1.1 Cycle machine power-using On/Off switch and allow completion of the self-test.
 - 7.21.1.2 Verify the ventilator switches to standby mode after completion of self-test.
 - 7.21.1.3 Connect a test lung (8401892) to the breathing circuit Y-piece, and attach to breathing system.
 - 7.21.1.4 Attach a breathing bag to the breathing bag connector of the breathing system.
 - 7.21.1.5 Select Man Spont.
 - 7.21.1.6 Set the fresh gas flow to 3 L/min.
 - 7.21.1.7 Set the APL valve to MAN, 30 cmH₂O.
 - 7.21.1.8 Verify that manual breathing is possible by manually squeezing the breathing bag. ___ (Y)
- (✓) 7.21.2 Spontaneous Breathing
 - 7.21.2.1 Set the APL valve to SPONT.
 - 7.21.2.2 Verify that spontaneous breathing is possible with the test lung. ___ (Y)
 - 7.21.2.3 Close O₂ flow control valve.
- (✓) 7.21.3 Flow Sensor Zeroing
 - 7.21.3.1 Select Standby mode and confirm.
 - 7.21.3.2 Disconnect the expiratory hose from the breathing system.
 - 7.21.3.3 Press the Calibrate Flow Sensor key and perform the on-screen instructions. At completion of calibration verify "Flow Calibration Completed" message appears.
 - 7.21.3.4 Reconnect the breathing circuit to the inspiratory and expiratory ports of the breathing system.

- (✓) 7.21.4 Ventilator Delivery
 - 7.21.4.1 Set APL to Man position and set to 30 cmH₂O.
 - 7.21.4.2 Switch to Volume Control mode and set the fresh gas flow to 3 L/min.
 - 7.21.4.3 Interconnect a test volumeter (P/N 2212300 w/4115087 connectors) between the expiratory limb of breathing system and breathing circuit.
 - 7.21.4.4 Is Volume Mode displayed and flashing? ___ (Y)
 - 7.21.4.5 Depress Flush momentarily to inflate bag.
 - 7.21.4.6 Set: pmax = 70 mbar (cmH₂O)
Vt = 380 mL
Freq = 12 BPM
TI:TE = 1:1
TIP:TI = 10%
PEEP = 0 cmH₂O
 - 7.21.4.7 Press the rotary knob.
 - 7.21.4.8 Is Volume Control displayed? ___ (Y)
 - 7.21.4.9 Verify that ventilation starts. ___ (Y)
 - 7.21.4.10 Does drive run quietly and smoothly ___ (Y)?
 - (✓) 7.21.4.11 Verify display Vte = 300 - 450 mL (___ mL/min.)
 - (✓) 7.21.4.12 Verify Minute Volume on test volumeter and MV on display are within 20% of each other.

7.21.5 PEEP Pressure Accuracy

- 7.21.5.1 After 10 breaths, press PEEP parameter button.
- (✓) 7.21.5.2 Verify displayed values for the following PEEP settings:

Setting	Displayed Value
0	0 + 2 cmH ₂ O
10	10 ± 2 cmH ₂ O or 20% of setting, which ever is greater
15	15 ± 2 cmH ₂ O or 20% of setting, which ever is greater

- 7.21.5.3 Return PEEP setting to Zero and confirm.

7.21.6 Pmax Accuracy

7.21.6.1 Connect a test pressure gauge in line with the pressure port connector of breathing system.

7.21.6.2 Remove test lung and seal off Y-piece.

(✓) 7.21.6.3 Verify test gauge display and breathing gauge values for the following Pmax settings:

Setting	Test Gauge Value
25	25 ± 5 cmH2O
40	40 ± 5 cmH2O
60	60 ± 5 cmH2O
70	70 ± 5 cmH2O

7.21.7 APL Valve Man/Spont

7.21.7.1 Set ventilator to Man Spont

	Lever APL Valve	Rotary Knob APL Valve
7.21.7.2	Set O2 and Air Fresh Gas flows to 10L/min ea. (20 L/min. total)	
7.21.7.3	Set APL valve to MAN, 30 cmH2O.	Set APL Valve to 40 cm H2O
(✓) 7.21.7.4	Verify pressure is 27 - 33 mbar (cmH2O) as shown on digital manometer.	Verify pressure is 34 - 46 mbar (cmH2O) as shown on digital manometer.
7.21.7.5	Set APL valve to SPONT.	
(✓) 7.21.7.6	Verify pressure display is 0 - 3 mbar (cmH2O).	

7.21.7.7 Set fresh gas flow to zero.

7.21.7.8 Reconnect test lung to breathing circuit and remove the test pressure gauge from the breathing system.

7.21.8 Pressure Limiting Valve Test

7.21.8.1 Set ventilator to Volume Control mode and confirm.

- 7.21.8.2 Set: $p_{max} = 40$ mbar (cmH₂O)
 - V_t = 600 mL
 - Freq = 6 BPM
 - TI:TE = 1:1
 - TIP:TI = 10%
 - PEEP = 0 mbar (cmH₂O)
- 7.21.9 Remove ventilator hose from ventilator and connect a digital manometer to the ventilator outlet port.

- (✓) 7.21.10 Verify relief valve opens between 70 and 80 mbar (cmH₂O) when ventilator is in inspiratory phase.

SV00561

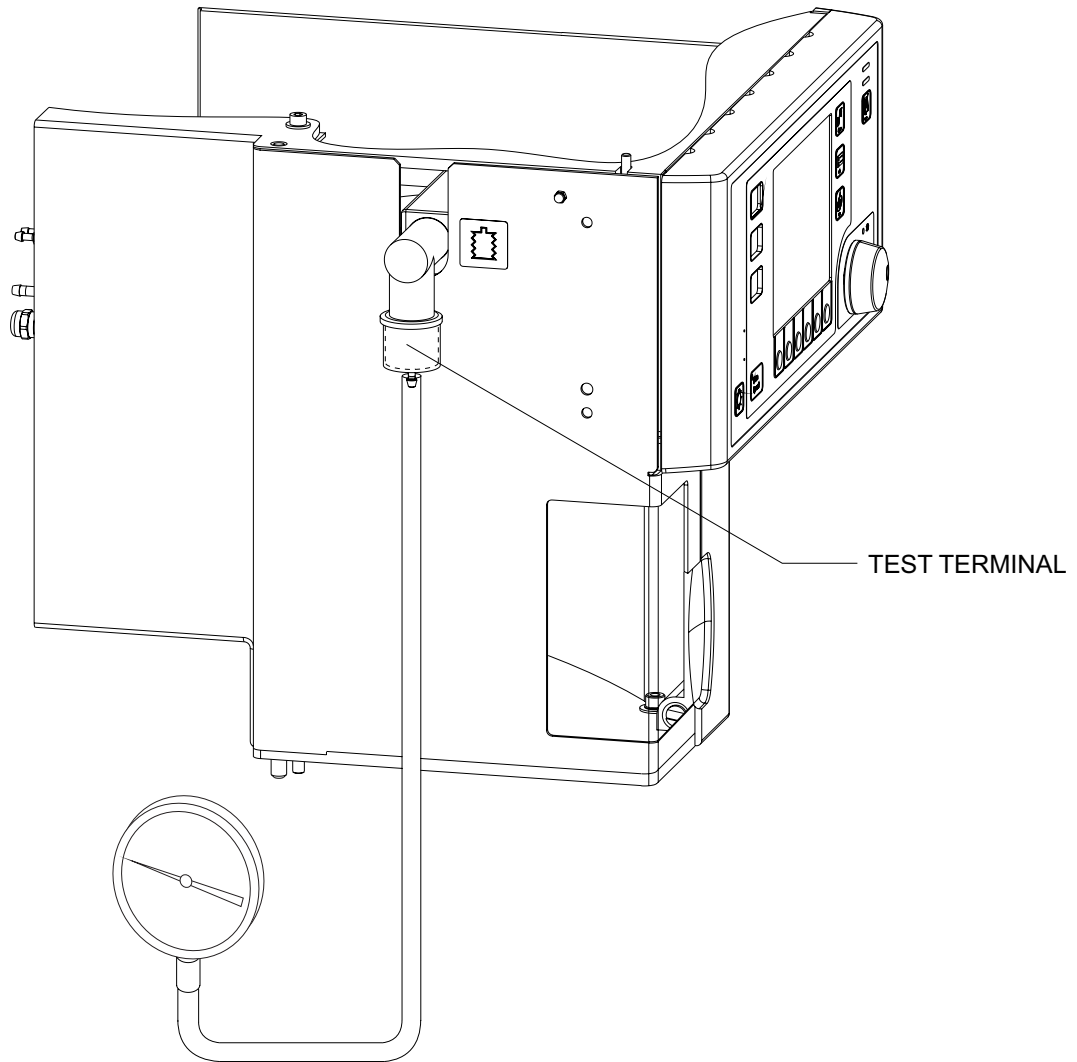

FRESH GAS LEAK TEST
DEVICE 4113119 (MODIFIED)

7.21.11 Auxiliary Air Valve Test

- (✓) 7.21.11.1 Close all flow control valves. Verify vacuum valve opens at the pressure indicated in the following table, when ventilator is in expiratory phase.

	Software Version	-3 mbar neg relief valve	-8 mbar neg relief valve
US	1.20	-2.5 to -6.0 mbar	N/A
	>1.3x	N/A	-7.0 to -8.0 mbar
non-US	1.20	-2.5 to -6.0 mbar	N/A
	>1.2x	N/A	-7.0 to -8.0 mbar

7.21.12 Piston Chamber Leak Test

NOTE: For software version ≤ 1.20 , proceed to the next step. For software version $\geq 1.3x$, skip to Part (b) of Step 7.21.12.5

7.21.12.1 Select Standby mode.

7.21.12.2 Connect test setup as shown in the illustration on the next page.

7.21.12.3 Press the Run Leak Test softkey.

NOTE: Do not run the leak test per on-screen instructions. Continue with piston chamber leak test as follows.

7.21.12.4 Use the O2 flow control valve to set a stable pressure of 30 cmH2O as shown on the display:

Paw cmH2O	O2 Flow mL/min
30	20

- (✓) 7.21.12.5 (a) Verify leakage rate is <20 mL/min. as shown on display.

(b) For software version 1.3x, perform the Leak/Compl Test and verify ventilator leak test indicates a Pass condition.

7.21.12.6 Remove test setups and reconnect ventilator hose to ventilator port.

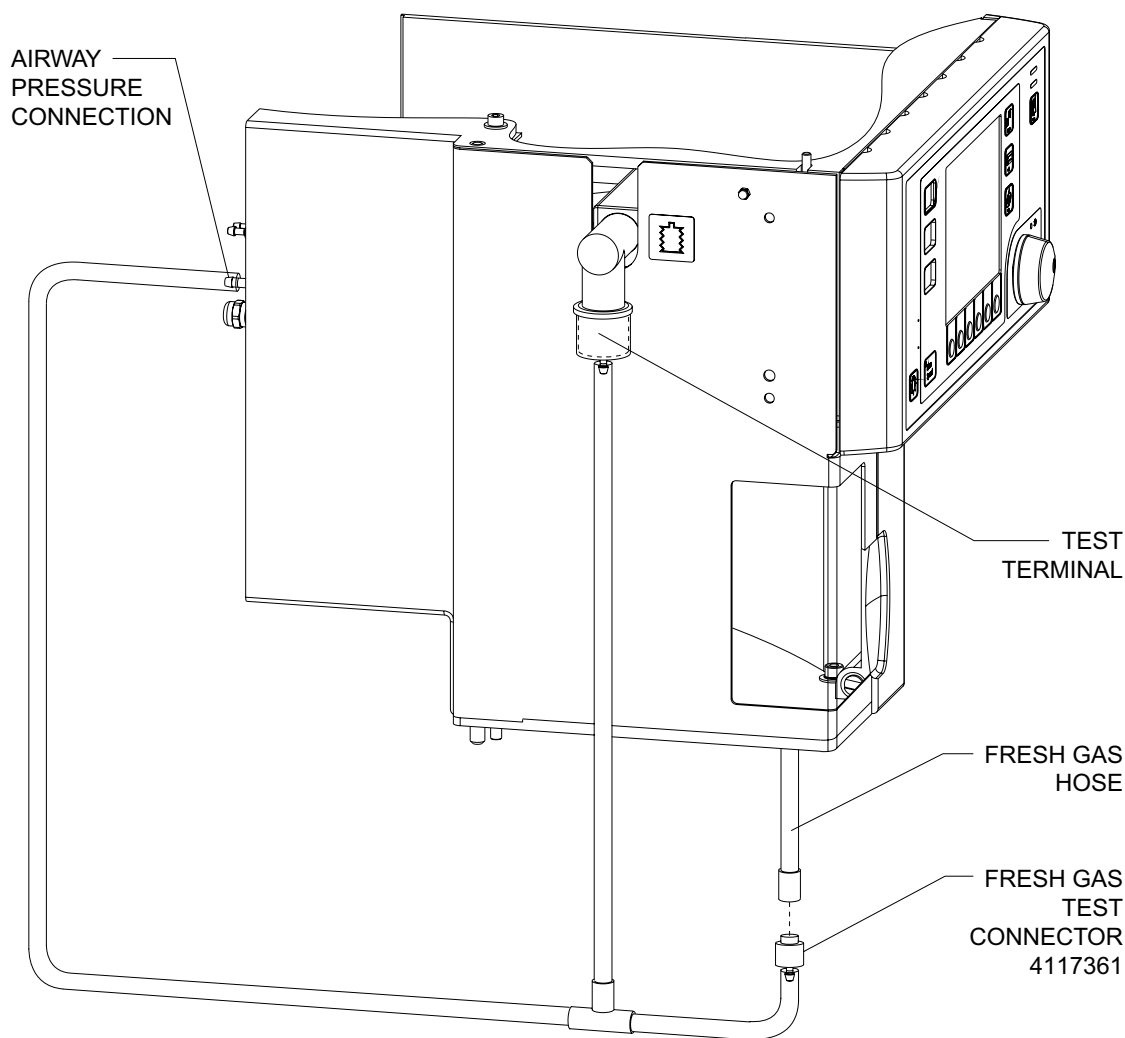

SV00548

FRESH GAS LEAK TEST
DEVICE 4113119 (MODIFIED)

7.21.13 Vacuum Pressure

7.21.13.1 Set Fabius GS to Volume mode.

7.21.13.2 Remove APL bypass hose from breathing system and attach to digital manometer.

(✓) 7.21.13.3 Verify vacuum is between -150 and -240 cmH₂O (mbar) (-110 and -175 mmHg) as shown on digital manometer. ___ cmH₂O

7.21.13.4 Disconnect APL bypass hose from digital manometer and reconnect to APL port on breathing system.

7.22 Volume Alarms

- 7.22.1 Set ventilator to Volume Control mode and confirm.
- 7.22.2 Set: $p_{max} = 40$ mbar (cmH₂O)
 $V_t = 380$ mL
Freq = 12 BPM
TI:TE = 1:1
TIP:TI = 10%
PEEP = 0 mbar (cmH₂O)
- 7.22.3 Press the Alarms key, scroll to MV High Alarm and confirm. Does a box appear around the Minute Volume High Alarm Limit? ___(Y)
- 7.22.4 What is the High Minute Volume Alarm default? ___ (12) Press to confirm.
- 7.22.5 Scroll to Minute Volume Low Alarm and confirm. What is the minute Volume Low default? (3.0)
- (✓) 7.22.6 Adjust the low minute volume alarm to 5.0 liters and confirm. Does the MINUTE VOLUME LOW !! alarm appear as a mid alarm with a corresponding yellow LED? ___ (Y).
- 7.22.7 Adjust minute volume alarm to 2.0 and confirm. Does the Minute Volume Low alarm disappear? ___ (Y).
- 7.22.8 Disconnect breathing hose from expiratory connection and start a stop watch.
- (✓) 7.22.9 What is the time when APNEA FLOW !! appears as a mid alarm? ___ sec (13 - 17)
- (✓) 7.22.10 What is the time when APNEA FLOW !!! appears as a high alarm? ___ sec (26 - 34)
- 7.22.11 Disconnect the respiratory volume sensor cord from the Flow sensor.
- (✓) 7.22.12 Does the "FLOW SENSOR FAIL !" message appear as an Advisory with a single audible tone? ___ (Y)
- 7.22.13 Does the APNEA FLOW !!! alarm disappear? (Y)
- 7.22.14 Do the numerical values associated with volume disappear? ___ (Y)
- 7.22.15 Reconnect the respiratory volume sensor cord to the flow sensor, and expiratory limb of breathing circuit to breathing system.
- 7.22.16 Press Standby, confirm, and recalibrate the flow sensor.

7.22.17 Fresh Gas Low

7.22.17.1 Select Volume Control mode and confirm.

7.22.17.2 Disconnect the hose attached to the breathing system's inspiratory port.

(✓) 7.22.17.3 After 30 seconds verify the APNEA PRESSURE !!!, APNEA FLOW !!!, MINUTE VOLUME LOW !!! and FRESH GAS LOW !! alarm messages appear on the display with a corresponding audible alarm.

7.22.17.4 Reconnect the patient Y connector to the patient inspiratory port and activate the flush.

7.22.17.5 Verify the FRESH GAS LOW !! alarm disappears after two (2) seconds following the next ventilator cycle. ____ (Y)

7.22.17.6 For software version 1.3n, with No Fresh Gas enabled, verify a No Fresh Gas !!! alarm appears.

(✓) **7.23 Audio Silence**

- 7.23.1 Press the  key.
- 7.23.2 Does the LED on the Silence Alarms key light? Is the audio alarm silenced for 120 sec.?
- 7.23.3 Press Standby key and confirm.
- 7.23.4 Cycle the system power and wait for the Standby screen to appear.
- 7.23.5 Press Volume Control and confirm.
- 7.23.6 Verify the 120-sec. delay starts at power-up.
- 7.23.7 Disconnect all test equipment.

(✓) **7.24 Oxygen Flush Valve**

7.24.1 Press and release the O₂FLUSH button.

7.24.2 Does the flow of oxygen stop immediately? __ (Y)

7.24.3 Connect a 12-inch hose to the inspiratory valve.

7.24.4 Occlude the bag mount with test plug.

7.24.5 Insert the sensor from a calibrated O₂ Med into the valve dome adapter on the inspiratory valve.

7.24.6 Close all flow control valves.

7.24.7 Press the O₂FLUSH button.

(✓) 7.24.8 What is the O₂ concentration after the value stabilizes? ___%O₂ (97-100)

7.24.9 Remove the O₂ sensor from the inspiratory dome and install the plug.

7.24.10 Disconnect the fresh gas hose from the breathing system. Using the fresh gas test connector (4117361), test terminal (4104389), and appropriate adapter (4115087), connect to fresh gas hose and attach test terminal to in port of test volumeter.

7.24.11 Press and hold the O₂ FLUSH button for 15 seconds; multiply the value by 4.

(✓) 7.24.12 What is the oxygen flush flow rate? ___L/min.

Minimum: 35 L/min. @ 50 psi (domestic)

Minimum: 25 L/min. @ 40 psi (2.8 bar)

Maximum: 75 L/min. @ 87 psi (6.0 bar)

7.24.13 Remove the test minute volumeter and test fixture, and reconnect the fresh gas hose.

7.24.14 Turn the System Power switch to ON.

7.25 Final Tests

- (✓) 7.25.1 Operator's Instruction Manual
 - 7.25.1.1 Verify that the availability/location of the machine's Operator's Instruction Manual is in close proximity of the machine.

- (✓) 7.25.2 Lamp Test
 - 7.25.2.1 Verify that the table lamp is working properly.

- (✓) 7.25.3 Final Check
 - 7.25.3.1 Verify that all cylinder pressure gauges indicate zero (if applicable).
 - 7.25.3.2 Verify that the pipeline hoses are connected to the hospital pipeline.
 - 7.25.3.3 Verify that the APL valve knob is fully open.
 - 7.25.3.4 Verify that the O₂ sensor is removed from the valve dome and the plug is inserted in the inspiratory valve dome.
 - 7.25.3.5 Verify that the machine is plugged into a live outlet.
 - 7.25.3.6 Verify all test equipment is removed from machine.
 - 7.25.3.7 Return all machine controls and settings to their original state.

8.0 SOFTWARE UPDATE PROCEDURE

This section outlines the basic software installation procedure, including the equipment needed and its connections. For specific software versions, refer to applicable Service Procedures.

NOTE: The screen illustrations contained in this document are for reference only and therefore may or may not reflect the current equipment or software version being installed.

8.1 REQUIREMENTS

NOTE:

U.S. units: Verify original machine software level prior to performing software download procedure. Software downloads from version 1.20 to 1.3x shall only be performed using Upgrade Kit P/N 4117917. Refer to Product Bulletin 143 for details.

Non-U.S. units: Verify original machine software level prior to performing software download procedure. Software download from version ≥ 1.22 to 1.3x shall only be performed using the appropriate upgrade kit. Refer to Product Bulletin 143 for details.

A SendImage (Utility) file is required to perform a Software download. See the following subsections that apply to loading or updating the SendImage file.

Equipment required:

--Cable Asm, Vitalink, Part No. 4110328 (9-pin to 9-pin)
Alternate cable combination: 7901808 and 7901762

--IBM[®] PC or IBM PC Compatible configured with:

- Windows 98, Windows NT, Windows 2000, Windows NT 4.0, or Windows XP
- RS-232C Serial port connected to COM 1 or COM 2
- Parallel port (LPT1 or LPT2)
- CD-ROM and Floppy Drive
- Standard sound card
- 2 PCMCIA slots (on laptops)
- Modem (or external modem) V34+ 28800 Baud

8.2 Installing Send Image (utility) file on laptop. (If applicable)

8.2.1 Turn on the PC and insert the software media in the appropriate drive.

8.2.2 Minimize all programs and check desktop area for the following icon.



NOTE: If the 'SendImage' icon exists on your laptop, proceed to Section 8.3 'Updating Send Image'.

8.2.3 Using Windows Explorer double click on the appropriate drive.



8.2.4 Double click on the 'send_image_install' file.

8.2.5 Double click on the 'Setup.exe' file.



8.2.6 Verify the following 'InstallShield Wizard' screen appears and the Destination Folder is C:. Choose 'Next'.

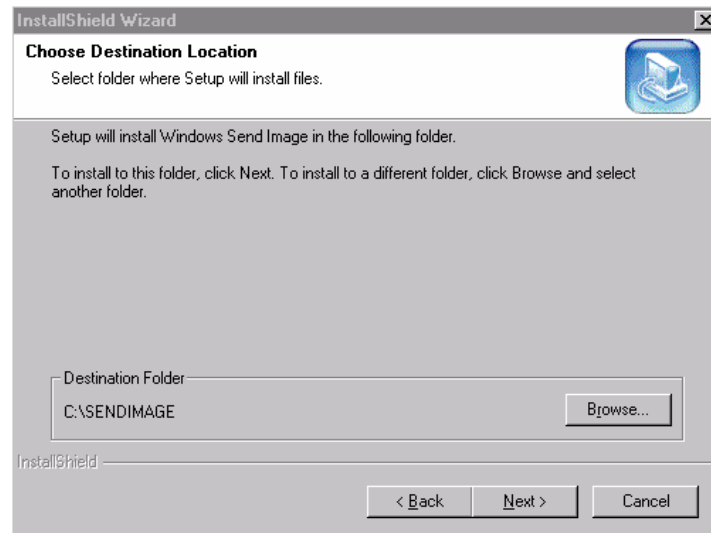

8.2.7 Choose 'Next' to the following screen.

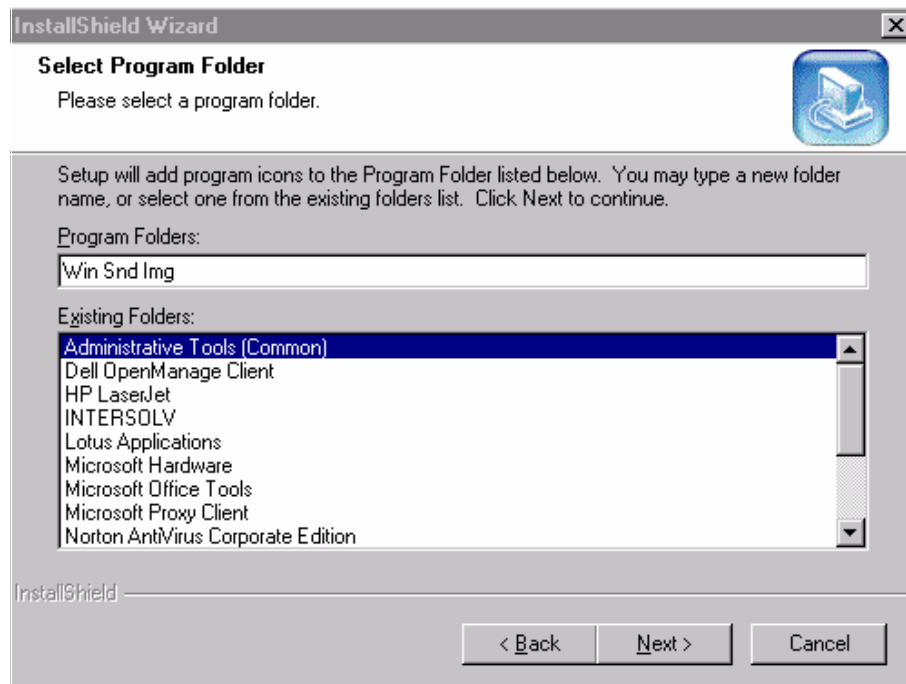

8.2.8 The following screen shall appear. Choose 'Finish'. Proceed to 'Updating Send Image File', Section 8.3.

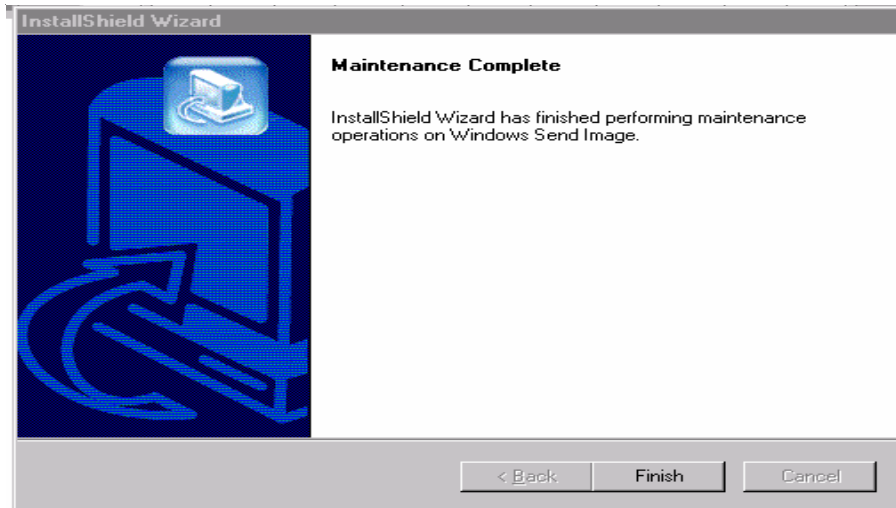

8.3 Updating Send Image (utility) file.

8.3.1 Minimize all programs and verify the 'Send Image' icon is located on the desktop.



8.3.2 Using Windows Explorer, double click on the appropriate drive and open the 'send_image_install' file.

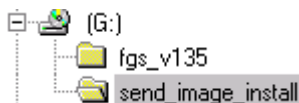

8.3.3 Double click on the 'copy_si.bat' file. This updates your current 'Send Image' file to the latest version. Proceed to 'Installing Fabius GS Software from a PC', Section 8.4.



8.4 INSTALLING FABIUS GS SOFTWARE FROM A PC

8.4.1 Record the market settings on the unit for re-configuration of the controller PCB after download. Refer to Section 4 to access the appropriate service screen.

The default "Market Selection" after download is "U.S." To change the language and pressure measurement units the "Market Selection" must be changed to "Non-U.S." Table 8-1 shows the proper market settings for each region.

- 8.4.2 Performing a software download from Software Versions 1.X to 2.X will disable any ventilator feature option(s) previously enabled. These options can be restored **after** the software update. Proceed with the following steps to restore these options:

Contact DrägerService - Technical Support: Phone: 1-800-4-Dräger, Phone: 215-721-5402, or e-mail to techsupport@draegermed.com and provide the following information to receive the necessary release codes:

- Machine Type (Fabius GS or Fabius Tiro)
- Feature Description and Part Number
- Machine Serial Number
- Device ID Number

- 8.4.3 From desktop, double-click the new icon named 'SENDIMG' or 'send_img'. The 'Communications Settings' screen will appear. Configure the 'Communications Settings' as follows:

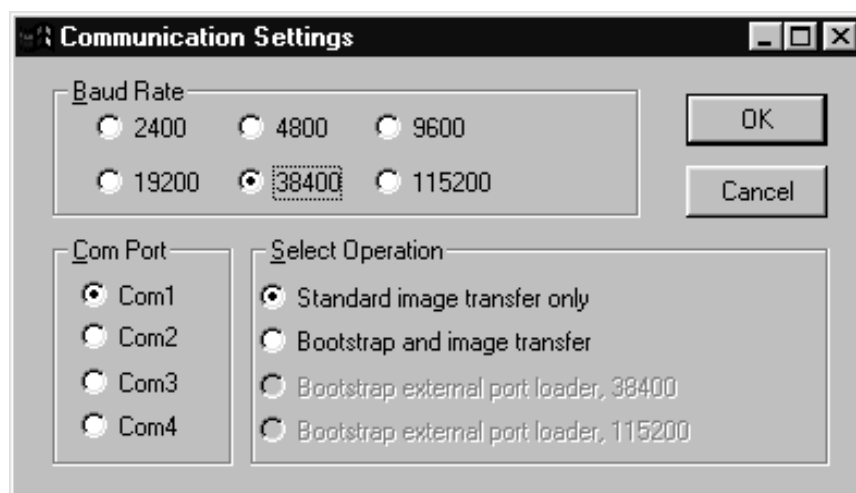

- 8.4.4 Press Enter or click OK. Connect the download cable from Com1 on the laptop computer to the serial interface port on the Fabius GS. See [Figure 8.1](#).

REAR VIEW OF FABIUS GS

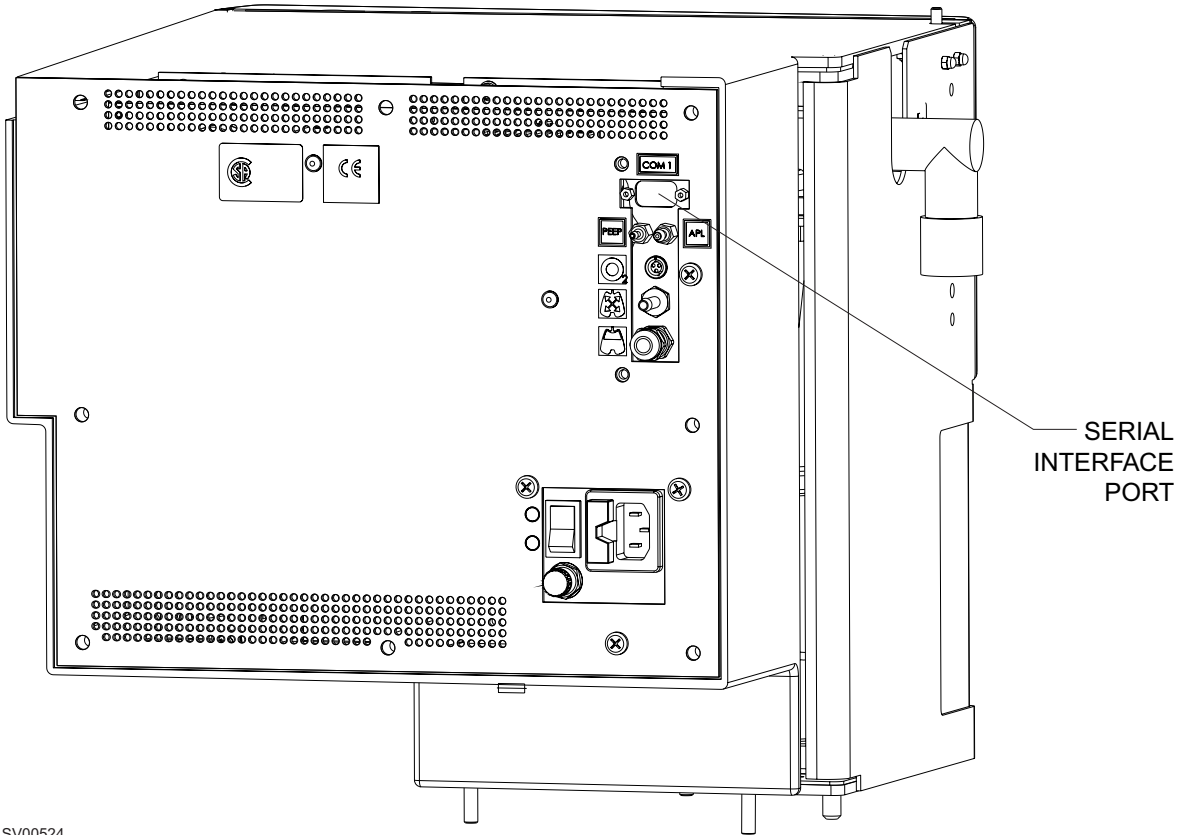

SV00524

FIGURE 8-1. Fabius GS Serial Port Location

8.4.5 From the drop-down box, select the CD Drive.

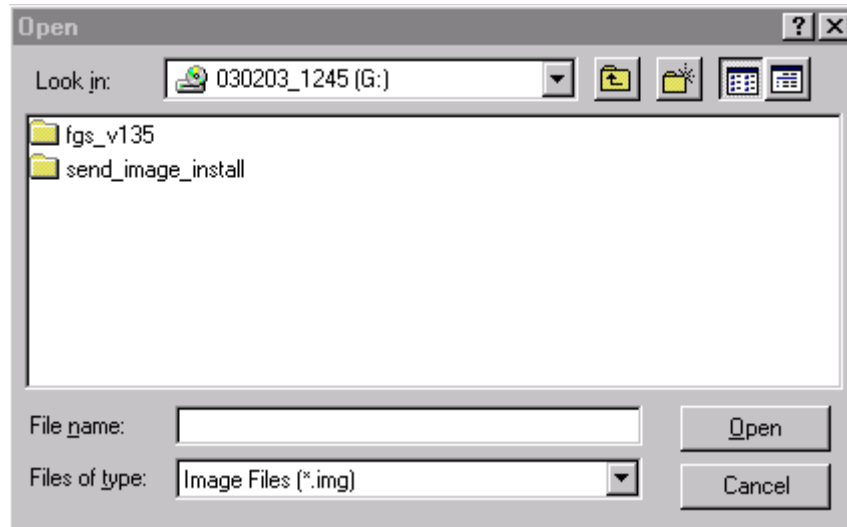

8.4.6 Double click the 'software image' folder (fgs_vxxx). The 'Fabius GS.IMG' is displayed.

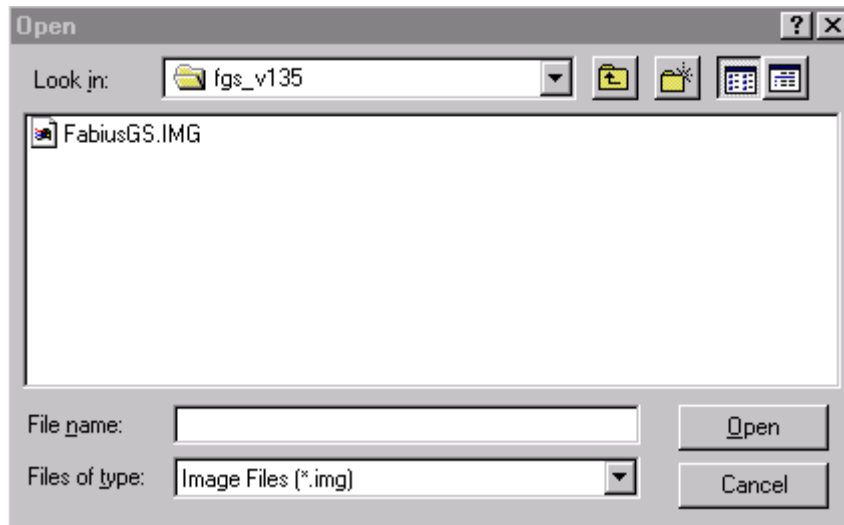

8.4.7 Double-click the '.IMG' file or single-click (highlight), then press 'Enter'. The following screen will be displayed:

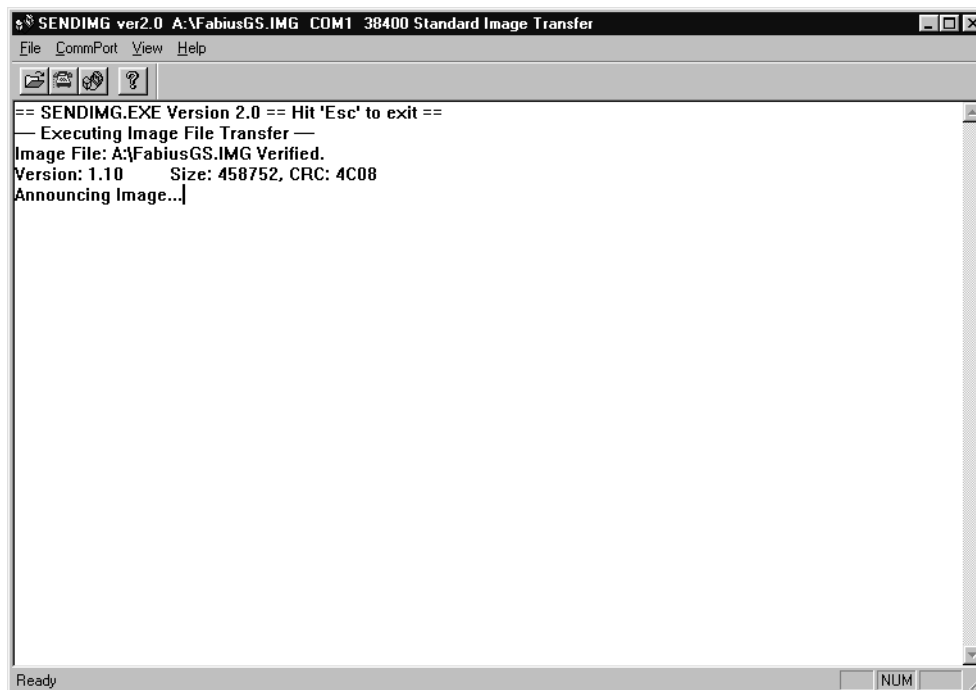

8.4.8 Set the machine's power switch to ON. The download process will start immediately.

- 8.4.9 As the software is downloading, programming blocks will appear on the machine display. See [Figure 8.2](#). When the download is complete and successful, the display will appear as shown in [Figure 8.3](#). If the download is unsuccessful, the display will appear as shown in [Figure 8.4](#).

- 8.4.10 Set the power switch on the Fabius GS to OFF. Close the PC loader screen and power down the PC. Disconnect the interface cable.
- 8.4.11 Switch machine power to ON and verify all self-diagnostics indicate a Pass condition, except for NAVRAM. The NAVRAM test may indicate a FAIL condition during the initial System Diagnostics after a successful software download.

NOTE: The NAVRAM test shall indicate a PASS condition after performing an additional power cycle.

- 8.4.12 Access the appropriate service screens (see Section 7.5 of the Fabius GS Service Manual) and update the machine serial number, clear service log and reset hours run. The machine serial number is located on the rear of the machine.
- 8.4.13 If applicable, enable previously configured ventilator feature option(s) by contacting DrägerService - Technical Support: Phone: 1-800-4-Dräger, Phone: 215-721-5402, or e-mail to techsupport@draegermed.com and provide the following information to receive the necessary release codes:

- Machine Type (Fabius GS or Fabius Tiro)
- Feature Description and Part Number
- Machine Serial Number
- Device ID Number

- 8.4.14 Perform PMS test Steps 7.6, 7.7, 7.17, 7.18, 7.20 and 7.21 in Section 7.0 of the Fabius GS Service Manual. Verify the correct market kit settings are entered per original machine configuration or customer requirements. See Table 8-1.

NOTE: To change the language and pressure measurement units, the “Market Selection” must be changed to “Non-U.S.” (see Section 4.0 of the Fabius GS Service Manual).

Table 8-1: Market Kit Settings

	O2 Whistle	Language	Date Format	Time Format	O2 Position	Alarm Sounds	Pres. Units
USA	Disabled	English	M/D/Y	12 Hour	Right	Drager	cmH2O
UK/Ireland	Enabled	UK English	D/M/Y	24 Hour	Left	EN740	mbar
France	Enabled	French	D/M/Y	24 Hour	Left	EN740	mbar
Germany	Enabled	German	D/M/Y	24 Hour	Left	EN740	mbar
Spain	Enabled	Spanish	D/M/Y	24 Hour	Left	EN740	mbar
Poland	Enabled	Polish	D/M/Y	24 Hour	Left	EN740	mbar
Italy	Enabled	Italian	D/M/Y	24 Hour	Left	EN740	mbar
Netherlands	Enabled	Dutch	D/M/Y	24 Hour	Left	EN740	mbar
Russia	Enabled	Russian	D/M/Y	24 Hour	Left	EN740	mbar
Sweden	Enabled	Swedish	D/M/Y	24 Hour	Left	EN740	mbar
Romania	Enabled	Romanian	D/M/Y	24 Hour	Left	EN740	mbar
Canada	Enabled	English	M/D/Y	12 Hour	Right	Drager	cmH2O
Egypt	Enabled	English	D/M/Y	24 Hour	Left	EN740	mbar
Mexico	Enabled	Spanish	D/M/Y	24 Hour	Right	Drager	mbar
Australia	Enabled	English	D/M/Y	24 Hour	Left	EN740	mbar
Hungary	Enabled	Hungarian	D/M/Y	24 Hour	Left	EN740	mbar
Turkey/Yugoslavia	Enabled	UK English	D/M/Y	24 Hour	Left	EN740	mbar
Belgium/Luxembourg	Enabled	French	D/M/Y	24 Hour	Left	Drager	mbar
Brazil	Enabled	Portuguese	D/M/Y	24 Hour	Right	EN740	mbar
Bulgaria/Finland	Enabled	UK English	D/M/Y	24 Hour	Left	EN740	mbar
Chile	Enabled	Spanish	D/M/Y	24 Hour	Right	EN740	mbar
Croatia	Enabled	Croatian	D/M/Y	24 Hour	Left	EN740	mbar
Cuba	Enabled	Spanish	D/M/Y	24 Hour	Right	Drager	mbar
Czech Republic	Enabled	Czech	D/M/Y	24 Hour	Left	EN740	mbar
Guam/Samoa	Enabled	UK English	D/M/Y	24 Hour	Left	EN740	mbar
Jamaica	Enabled	UK English	D/M/Y	24 Hour	Left	EN740	mbar
Paraguay	Enabled	Spanish	D/M/Y	24 Hour	Right	EN740	mbar
Portugal	Enabled	Portuguese	D/M/Y	24 Hour	Left	EN740	mbar
Slovak Republic	Enabled	Slovak	D/M/Y	24 Hour	Left	EN740	mbar
Switzerland	Enabled	German	D/M/Y	24 Hour	Left	EN740	mbar
Thailand	Enabled	UK English	D/M/Y	24 Hour	Left	EN740	mbar
Uruguay	Enabled	Spanish	D/M/Y	24 Hour	Right	Drager	mbar
Vietnam	Enabled	UK English	D/M/Y	24 Hour	Right	EN740	mbar
Argentina	Enabled	Spanish	D/M/Y	24 Hour	Right	Drager	cmH2O

8.5 Boot Strap Download Procedure

This procedure uses Version 2.x of the SEND.IMG program. V2 is a new Win32 program that adds the Fabius GS boot Strap load function to the original SENDIMG.EXE program that is currently used in existing products.



When a Fabius GS does not have a valid bootable image installed, it can not perform an Automatic Image Reload Operation. The same PC and files are used (including SENDIMG.EXE V2).

NOTE:

U.S. units: Verify original machine software level prior to performing software download procedure. Software downloads from version 1.20 to 1.3x shall only be performed using Upgrade Kit P/N 4117917. Refer to Product Bulletin 143 for details.

Non-U.S. units: Verify original machine software level prior to performing software download procedure. Software download from version ≥ 1.22 to 1.3x shall only be performed using the appropriate upgrade kit. Refer to Product Bulletin 143 for details.

- 8.5.1 Record the market setting on the unit for reconfiguration of the controller PCB after download. Refer to Section 4 to access the appropriate service screen.
- 8.5.2 Set the machine power switch to the OFF position.
- 8.5.3 Remove the back panel and change the JP2 (on control PCB P/N 4116632) or JP3 (on control PCB P/N 4118079) connector on the control

PCB from the Boot Flash position  to the Boot Strap position .

Refer to

[Figure 8.5](#) or [Figure 8.6](#) for proper connector locations.

- 8.5.4 Connect the 3-pin plug end of the boot strap download cable (P/N 4117459) to J13 on the control PCB. See [Figure 8.5](#) or [Figure 8.6](#) for proper connector locations.
- 8.5.5 Connect the DB9 end of the cable to the Com1 port on the PC.

- 8.5.6 Power up the PC and double-click the “send_img” icon on desk top. The following screen will appear:

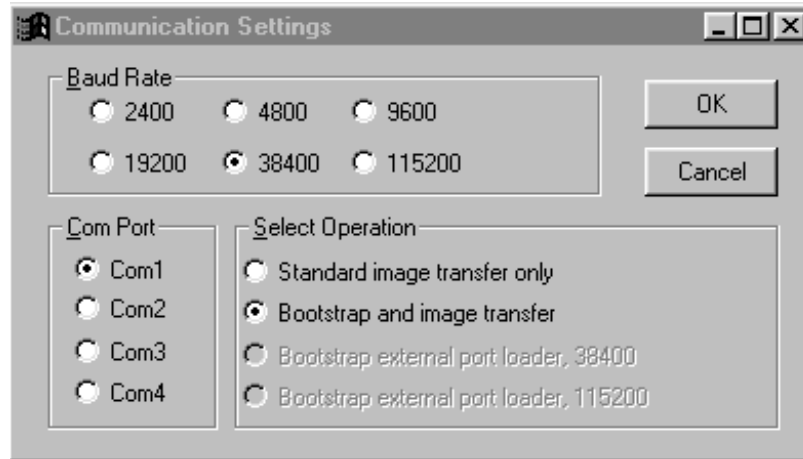

- 8.5.7 Choose “Boot Strap and Image transfer”, then click OK or press Enter.

- 8.5.8 Set the machine power switch to ON. The bootstrap load of the FLASH programmer load program then proceeds according to the status messages on the PC. The following screen will be displayed:

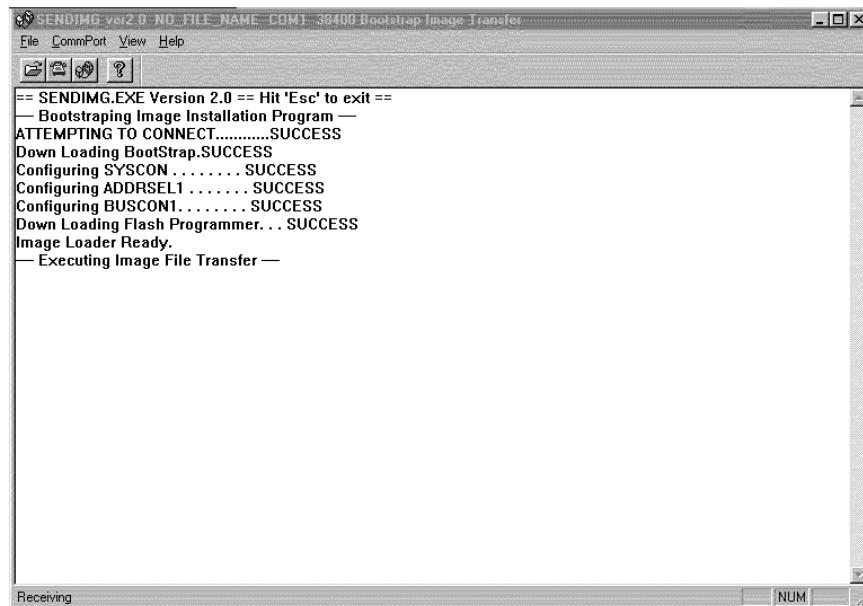

- 8.5.9 Follow the same sequence as a normal download procedure to access the software. See [Step 8.4.5](#). Once the load program is executing on the machine, the image load will proceed according to messages on the machine and the PC until a message on the machine indicates completion.

- 8.5.10 Close the PC Loader screen and power down the PC.

- 8.5.11 Disconnect the boot strap download cable.
- 8.5.12 Return the boot selector jumper at JP2 (on control PCB P/N 4116632) or JP3 (on control PCB P/N 4118079) to the Boot Flash position. 
- 8.5.13 Cycle machine power and verify all self-diagnostics indicate a PASS condition. NOTE: NVRAM settings will be set when [Step 8.5.16](#) is performed.
- 8.5.14 Reinstall the back panel of the control unit.
- 8.5.15 Access the appropriate service screens (see Section 7.5 of the Fabius GS Service Manual) and update the machine serial number, clear service log and reset hours run. The machine serial number is located on the rear of the machine.
- 8.5.16 Perform PMS test Steps 7.6, 7.7, 7.17, 7.18, 7.20 and 7.21 in Section 7 of the Fabius GS Service Manual. Verify the correct market kit settings are entered per original machine configuration or customer requirements. See [Table 8-1](#).

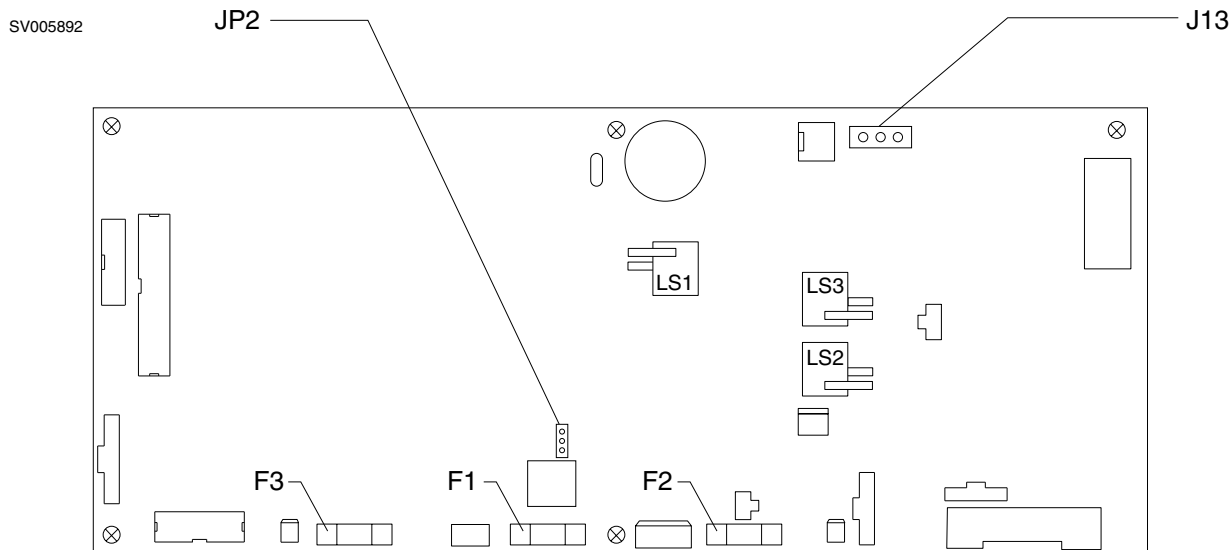

FIGURE 8-5. Boot Strap Jumper and Download Connections on Control PCB P/N 4116632

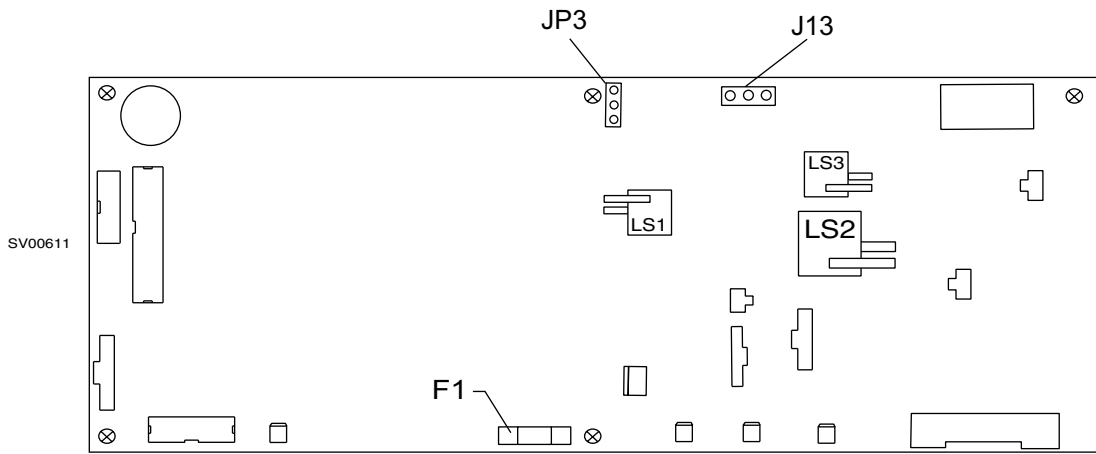

FIGURE 8-6. Boot Strap Jumper and Download Connections on Control PCB P/N 4118079

9.0 Spare and Replacement Parts

Part numbers for field-replaceable items on the Fabius GS anesthesia system are listed on the following pages, along with part numbers for related hardware and cables.

The item numbers are keyed to the accompanying illustrations to aid in identifying the item and its location.

NOTE: Certain items in the following parts listings include an “alternate part number” corresponding to those original part numbers that exceed seven (7) digits. Use the original part number whenever possible when ordering spare or replacement parts.

ASSEMBLY/PART	PAGE
Trolley assembly, O2 Flush Valve, Writing tray	9-3
Spirolog flow sensor, O2 sensor, Fresh gas hose	9-5
Breathing system assembly w/APL bypass	9-7
Breathing Arm Extension	9-9
COSY absorber top	9-11
COSY absorber canister	9-13
Breathing system mount assembly; Gauge assembly, patient airway pressure	9-15
Fresh Gas Flow Meter (part of flow meter bezel assembly)	9-17
Flow control valves & valve manifold (part of flow meter bezel assembly)	9-19
Fresh gas flow sensors & filter asm (part of flow meter bezel assembly) (Applicable to Fabius GS machines Serial Number 12191 and lower)	9-21
Fresh gas flow sensors & filter asm (part of flow meter bezel assembly) (Applicable to Fabius GS machines Serial Number 12191 or higher)	9-23
Pipeline pressure gauges (part of flow meter bezel assembly)	9-25
SORC (part of flow meter bezel assembly)	9-27
Fresh gas display PCB (part of flow meter bezel assembly)	9-29
Cylinder Yokes, Regulators, and Gauges:	9-31
Gas Inlet Assembly	9-33
Controller PCB and related parts (part of controller assembly P/N 4116400)	9-35
Pneumatic Assembly	9-37
Bezel Assembly, Monitor	9-39
Ventilator	9-41
Auxiliary O2 Flow Meter	9-43
Vapor mounting systems	9-45
Scavenger, AGS	9-47
AGS Scavenger kit w/adj valve	9-49

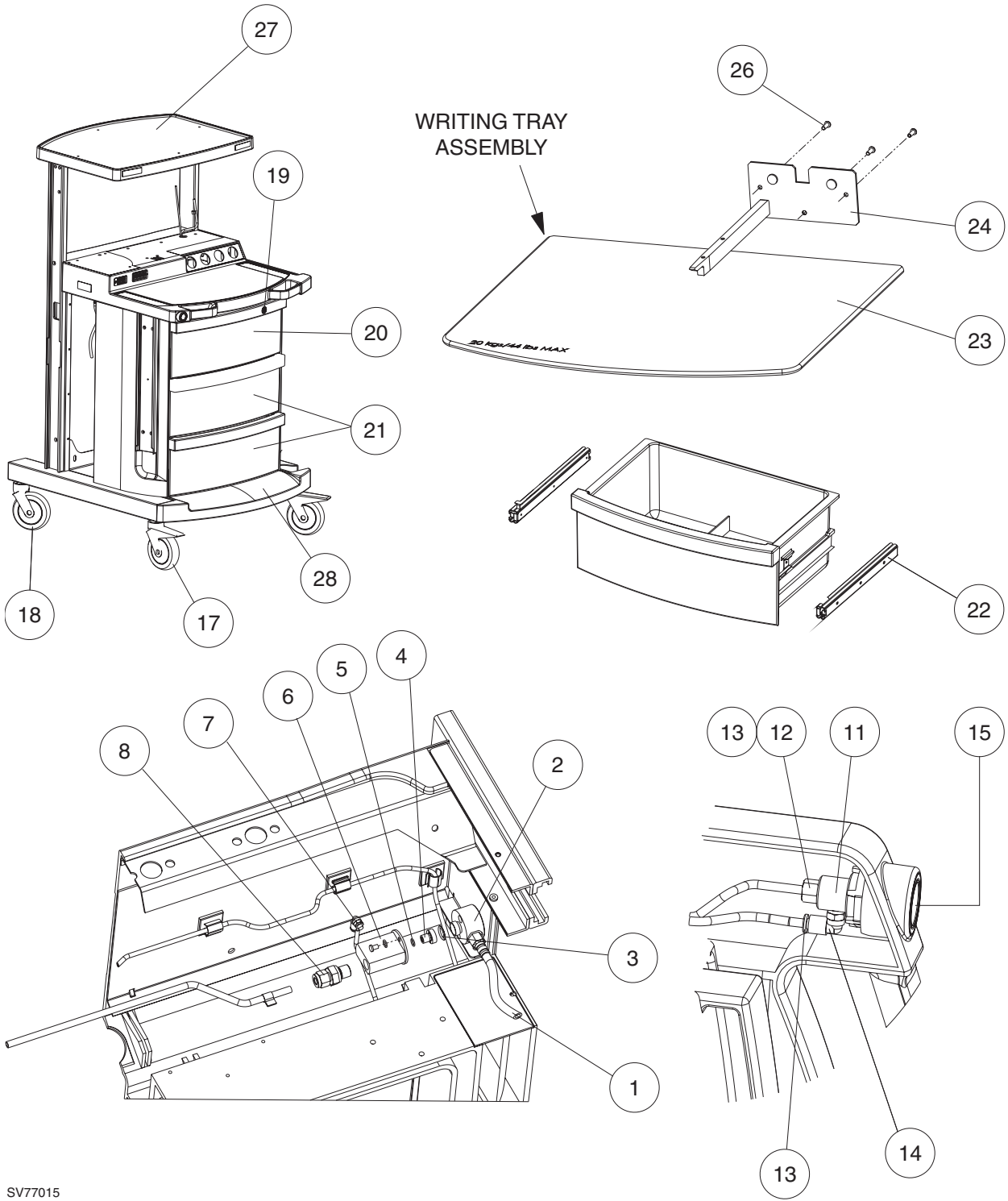

SV77015

ITEM	DESCRIPTION	PART NUMBER
1.	Fresh gas hose assembly	4108577-002
	Alternate part number	4199941
2.	Connector cone, mix gas	4117046
3.	O-ring	E20278
4.	Pressure nozzle	4117167
5.	O-ring, 6mm ID x 1mm W	4117208
6.	Connector lump	2600503
7.	Angle connector	M30953
8.	Straight fitting, 1/4 tube x M12	4109408-002
9.	Deleted	
10.	Lock washer, M4 split (2x)	1293680
11.	Valve assembly, Fresh Gas (without Label - See item #15 for Label P/Ns)	4117226
12.	Straight connector, M5	M30952
13.	Washer, M4 white	M31602
14.	Angle connector	M30953
15.	Label, O2 flush:	
	Germany, Austria, France, Spain	2600494
	USA	M28934
16.	Deleted	
17.	Caster, locking (2x)	8411945
18.	Caster (2x)	8411946
19.	Drawer lock	4117035
20.	Drawer (top) includes clips	4117036
21.	Drawer (middle & bottom) includes clips (2x)	AF00007
22.	Drawer Slide (6x)	4117008
23.	Writing tray	4117100
24.	Stop, tray pull-out	4117037
25.	Deleted	
26.	Screw, M4 x 12 mm self tap (3x)	4117021-001
27.	Tray Top, Fabius GS	4117875
28.	Bumper, foot rest	4116845

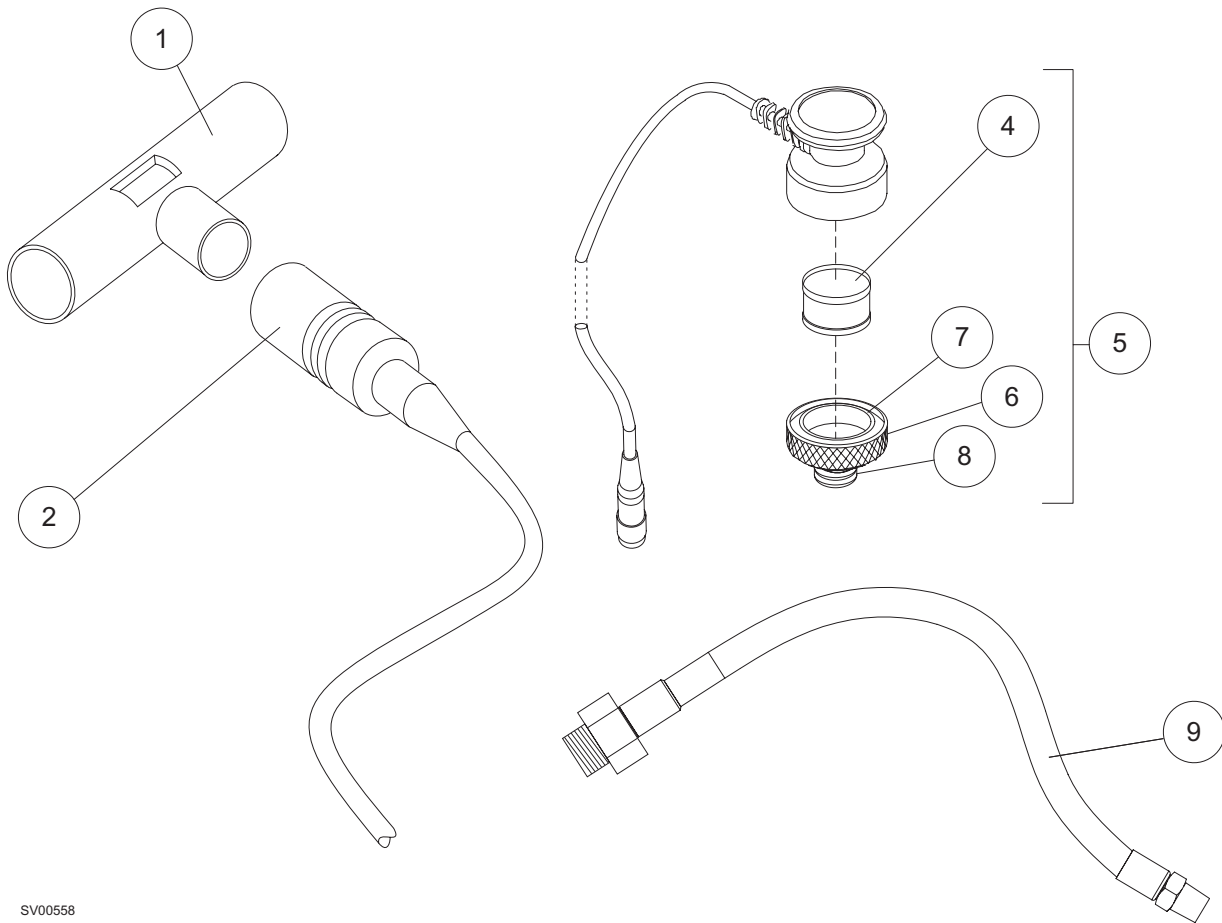

SV00558

ITEM	DESCRIPTION	PART NUMBER
1.	Spirolog flow sensor, 5 pack	8403735
2.	Spirolog cable assembly, COSY	4117081-001
	Alternate part number	4199951
3.	Deleted	
4.	Sensor capsule	6850645
5.	Housing assembly, less capsule	4117454
6.	Adapter (cover)	4106385
7.	O-ring, #025 (Viton)	4105791
8.	O-ring, #016 (Viton) (2x)	4106388
9.	Fresh gas hose assembly	4108577-002
	Alternate Part Number	4199941
	Fresh gas hose assembly - Right Hand	4108577-003
	Alternate Part Number	4199910
Miscellaneous Items (Not Shown)		
	Hose Asm - Silicon - Ventilator	4117590
	Hose Asm - Silicone - Ventilator - Right Hand COSY	4117152-001
	Hose Asm - Peep/PMax - APL Bypass	4117027
	Hose Asm - Peep/PMax - APL Bypass - Right Hand COSY	4117027-001
	Hose Trough - Plate - Right Hand COSY	4118459

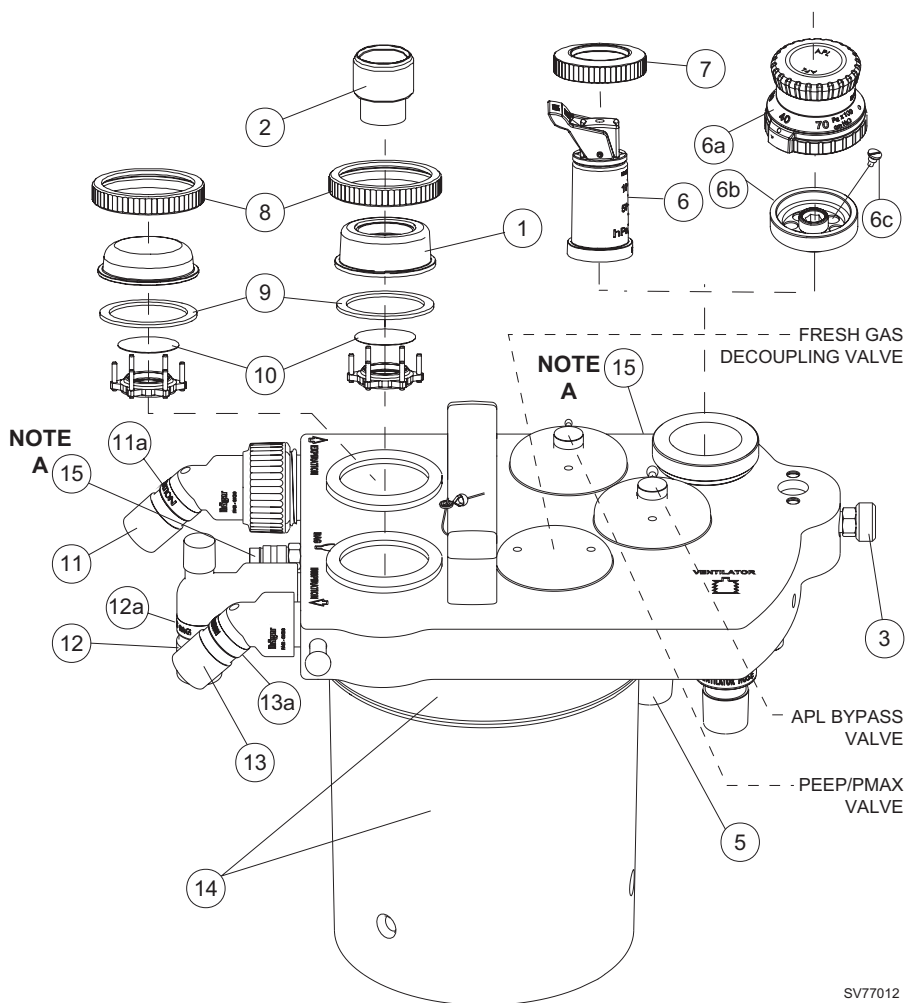

SV77012

NOTE A - DEPENDANT UPON THE CONFIGURATION OF THE COSY CURRENTLY INSTALLED,
 ITEM NUMBER 15 MAY BE LOCATED IN EITHER POSITION SHOWN ON ILLUSTRATION.

FABIUS GS	SPARE AND REPLACEMENT PARTS (continued)
------------------	--

ITEM	DESCRIPTION	PART NUMBER
1.	Dome, insp valve	4107960
2.	Plug assembly, O2 sensor	4115265
3.	Plunger	4117399
4.	Deleted	
	Breathing system assembly w/APL bypass, Service Exchange (new style)	SE4118378
	Alternate part number.	4199939
	Breathing system assembly w/APL bypass, Service Exchange.	SE4116398
	Breathing system assembly - Non-US, (new style)	4118379
	Breathing system assembly - Non-US	4117529
	NOTE: Verify the style of the original breathing system for its equivalent replacement. See the following figure for details.	
5.	Scavenger port assembly	4116715
6.	APL valve assembly (lever style)	4117149
6a.	APL valve assembly (rotary knob style)	MK00625
6b.	Crater asm - Kit (includes O-rings and shoulder bolt)	4118168
6c.	Shoulder Bolt.	4118166
7.	Retaining nut	M30448
8.	Union nut (2x)	M30453
9.	Packing ring (2x)	M09231
10.	Valve disk (2x)	2123249 or M23225
11.	Exp. hose terminal (incl. O-ring)	8603275
11a.	Label - Exp.	4118054-002
12.	Bag mount port	8603276
12a.	Label - Breathing Bag.	4118054-003
	O-ring.	M20622
13.	Insp. hose terminal	8603249
13a.	Label - Insp.	4118054-001
	O-ring.	M20622
14.	Absorber top & canister	See parts lists on subsequent pages
	Fresh gas decoupling valve:	
	Cap.	2600734
	O-ring, cap	8603336
	Spring Cross	M17450
	Diaphragm, Viton	8604105
	Crater.	2600737
	PEEP/Pmax valve:	
	Cap & hose barb assembly	4116714
	O-ring.	8603336
	Diaphragm asm.	4117885
	Crater.	2600731
	Sealing ring	2600479
	APL bypass valve:	
	Cap & hose barb assembly	4116929
	Spring	4116925
	Spacer, spring holder	4116926
	Crater assembly	4116933
15.	Sample line gas return fitting (non-U.S. breathing systems).	2600751

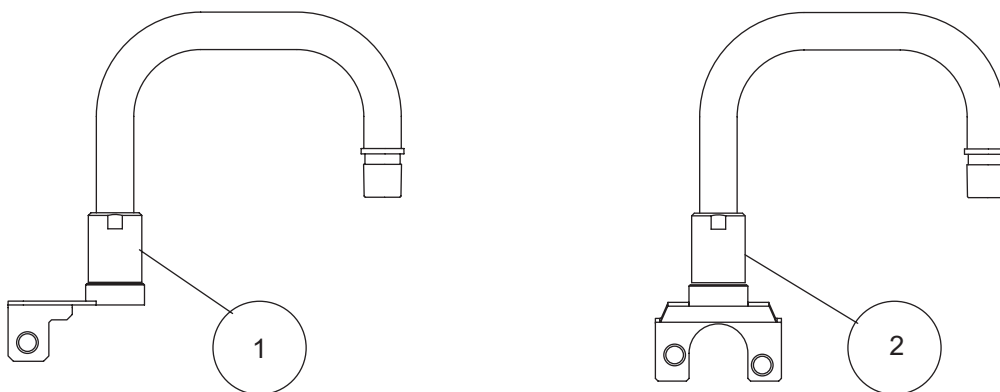

TYPICAL BREATHING BAG EXTENSION CONFIGURATIONS

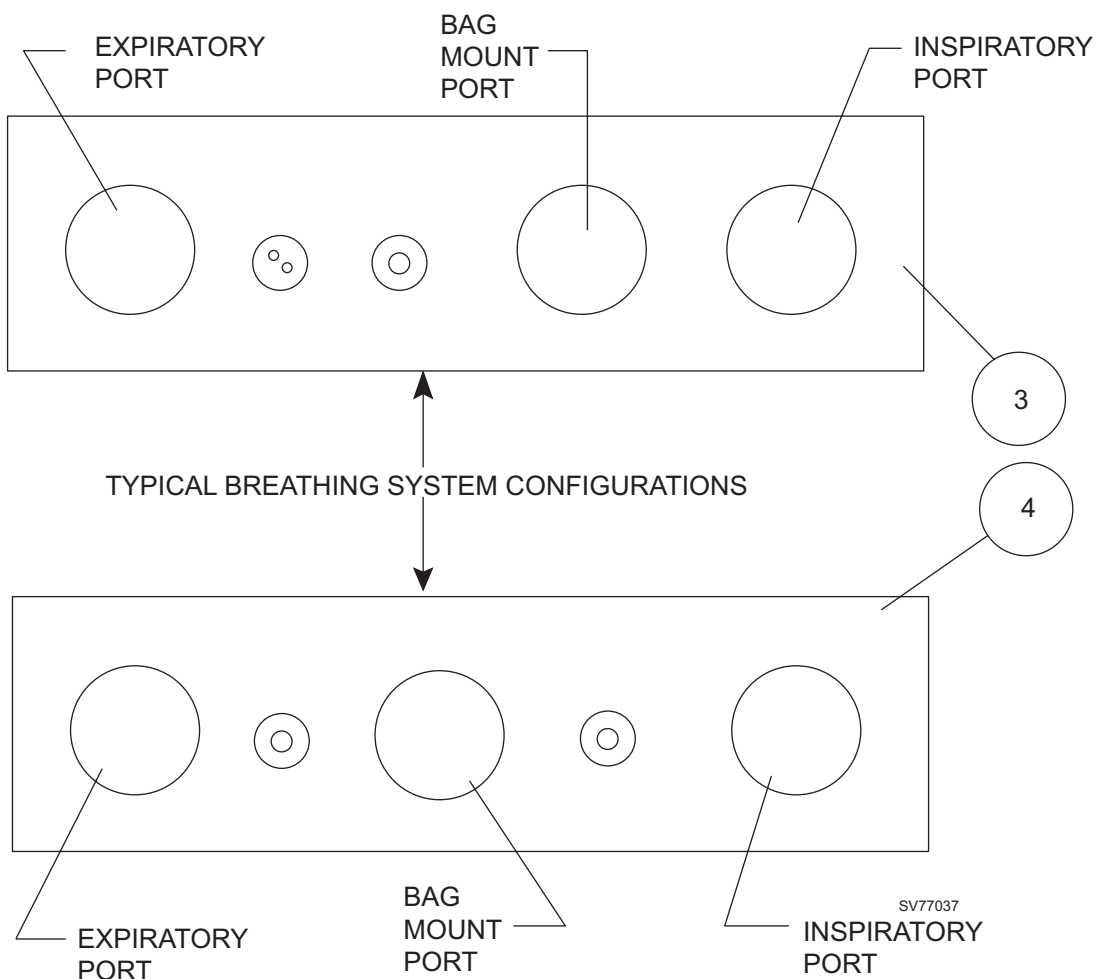

TYPICAL BREATHING SYSTEM CONFIGURATIONS

FABIUS GS	SPARE AND REPLACEMENT PARTS (continued)
------------------	--

ITEM	DESCRIPTION	PART NUMBER
1.	Pole Assembly, Breathing Bag Extension (for use with item #3).....	4117753
2.	Pole Assembly, Breathing Bag Extension (for use with item #4).....	4118380
3.	Breathing System Configuration (for reference only)	N/A
4.	Breathing System Configuration.....	SE4118378

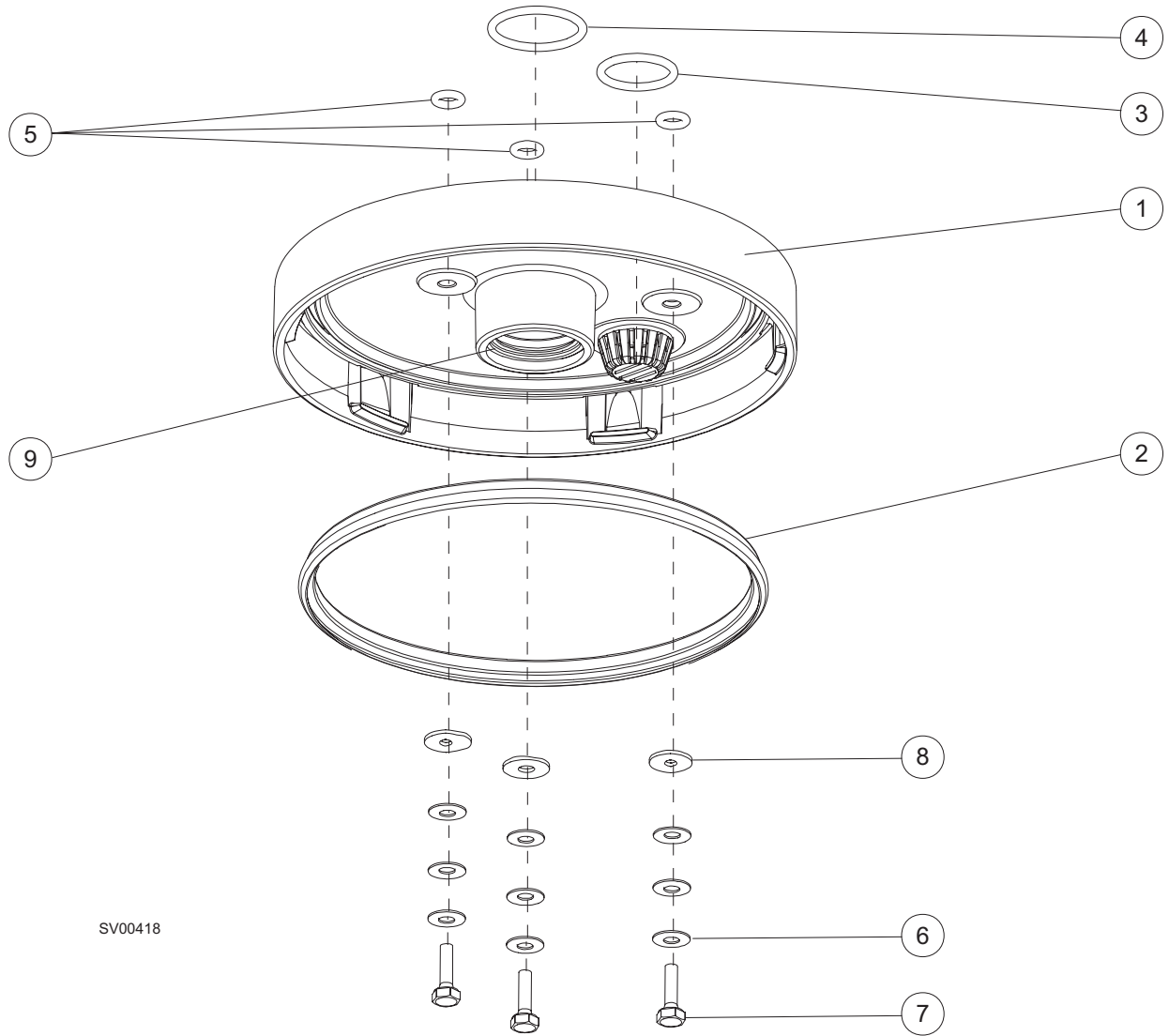

SV00418

ITEM	DESCRIPTION	PART NUMBER
1.	Absorber top	M33013
2.	Lip seal	M30455
3.	O-ring	R50313
4.	O-ring	R18352
5.	O-ring (3x).....	4302469
6.	Washer (9x).....	2600459
7.	Screw (3x).....	1266225
8.	Washer (3x).....	1329472
9.	Packing ring	M30456

SV00419

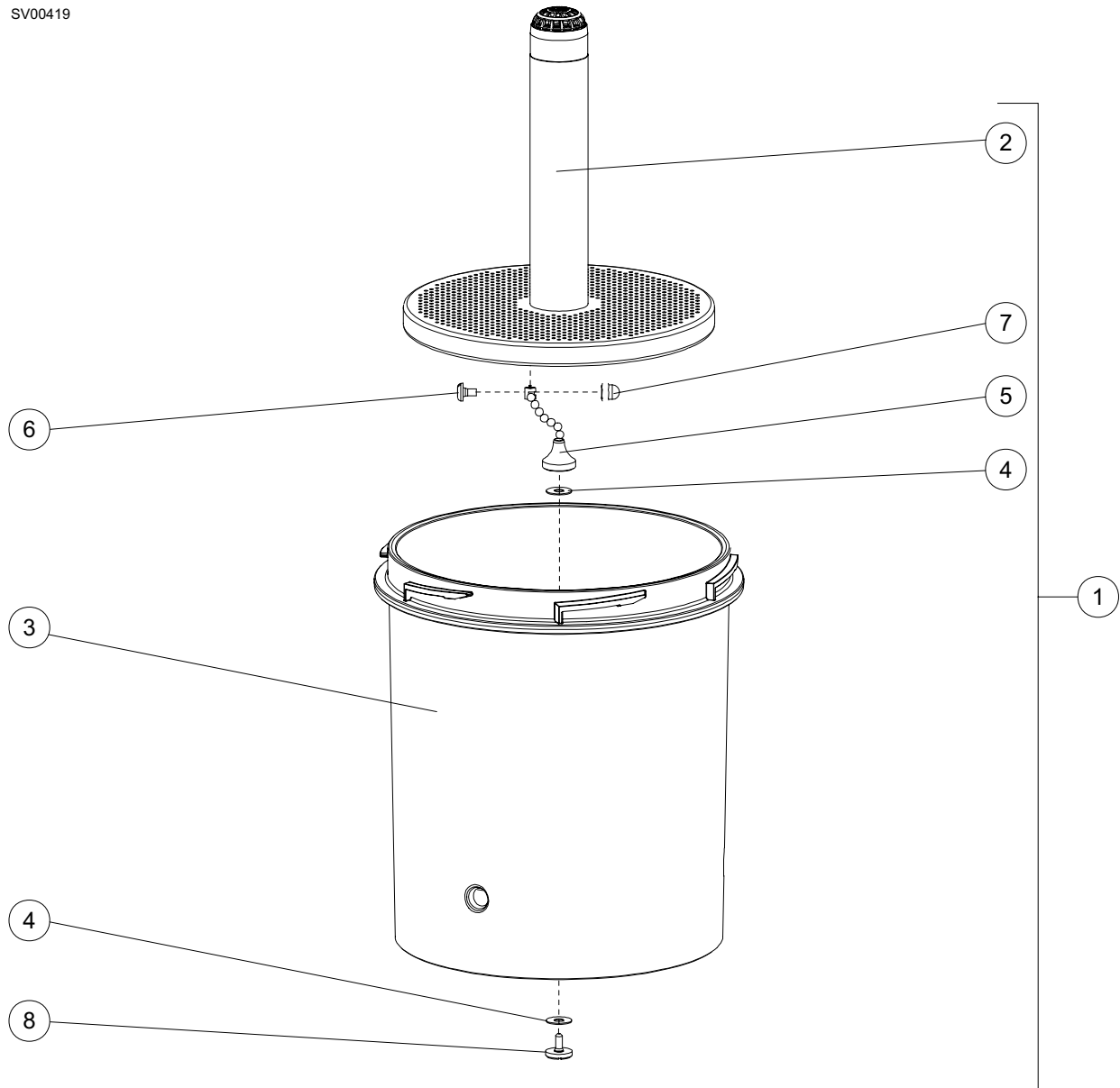

ITEM	DESCRIPTION	PART NUMBER
1.	Canister assembly	M29320
2.	Screen insert	M29999
3.	Canister	M29994
4.	Packing ring	M30563
5.	Bead chain	M30562
6.	Screw, oval hd AM4 x 6 DIN 85 - A4	1315838
7.	Acorn nut, M4 DIN 1587 - M A4/051	1334751
8.	Screw, M4 x 8 DIN 921 - A2	1336029

SV77026

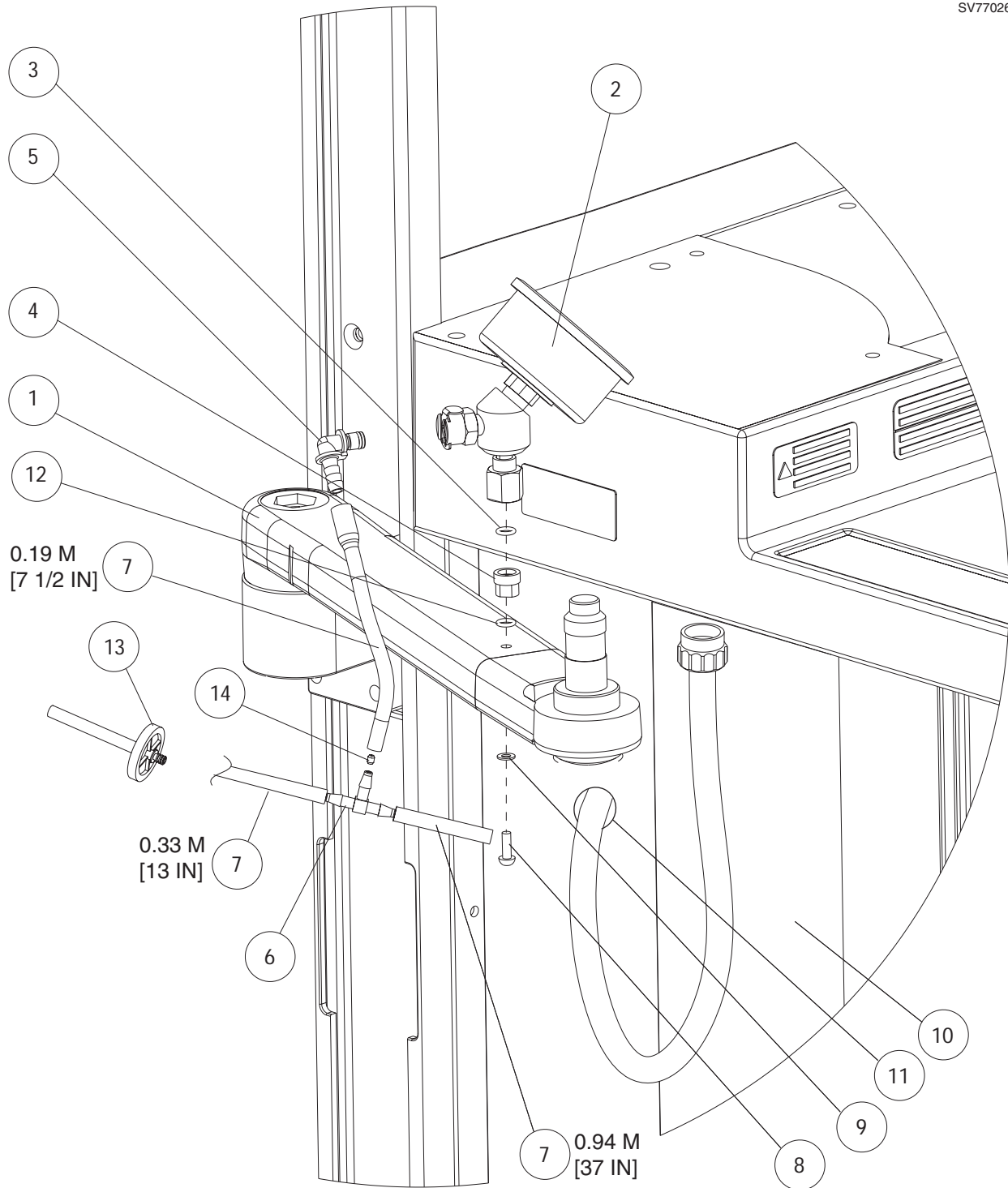

FABIUS GS	SPARE AND REPLACEMENT PARTS (continued)
------------------	--

ITEM	DESCRIPTION	PART NUMBER
1.	Breathing system mount assembly4117400
	Breathing system mount assembly, Right Hand COSY	4117400-002
	Alternate Part Number	4199772
2.	Pressure gauge assembly4114290
3.	O-ring, #010 (neoprene)	4101872
4.	Gauge mount adapter4117072
5.	Hose barb coupling, 90 deg4117070
6.	T-fitting, 5/32 ID tube	4109292
7.	Hose, 4 x 1.5 SI NF clear1190520
8.	Screw, 8-32 x 1/2 in. btn hd skt	HW09002
9.	Lock Washer, #8 int-t	HW67000
10.	Side Panel Option, left4117401
	Side Panel Option, right4117400
11.	Grommet, hole, 7/8 dia x 11/16 I.D.4113737
12.	O-ring, #109 (EPDM)	4112628-001
13.	Filter	8402868
14.	Restrictor4118440

SV00477

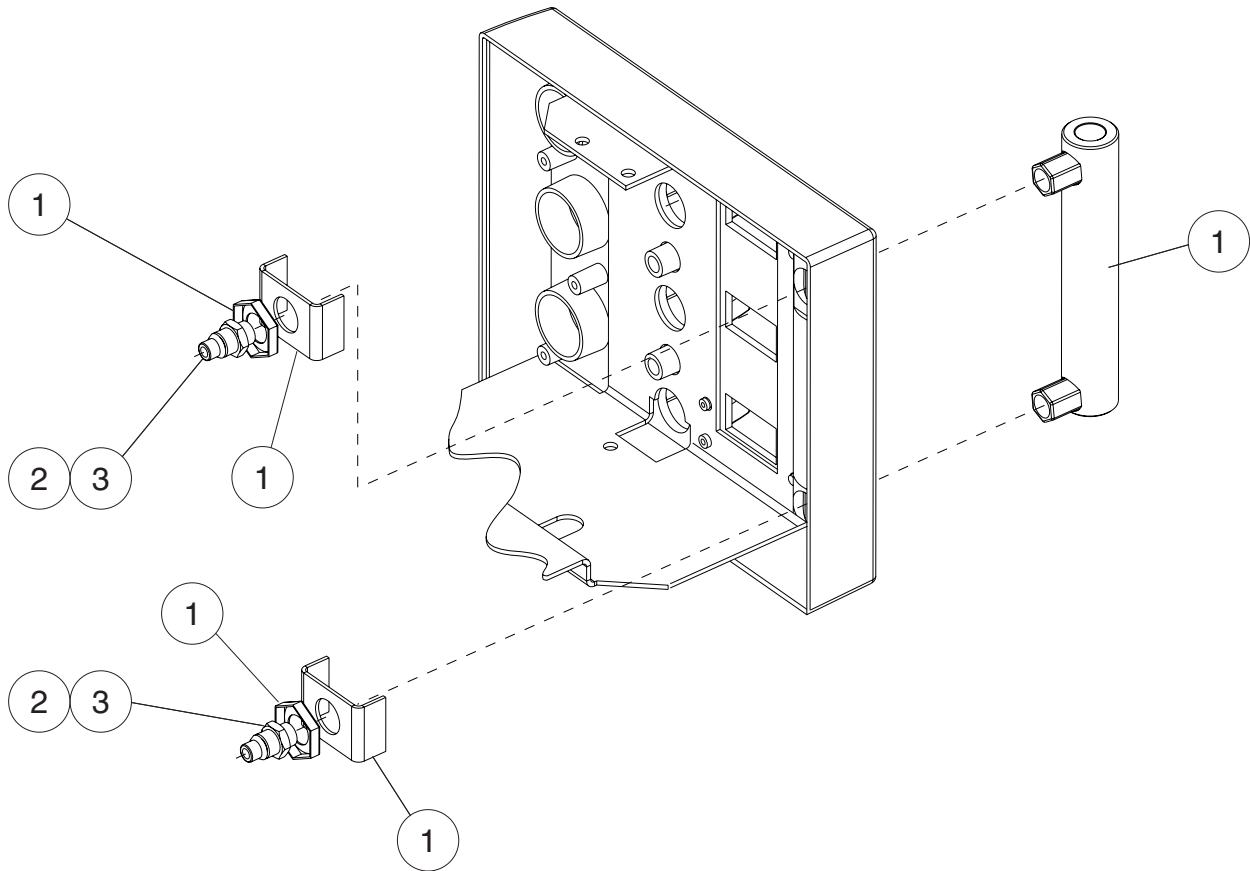

FABIUS GS	SPARE AND REPLACEMENT PARTS (continued)
------------------	--

ITEM	DESCRIPTION	PART NUMBER
	Fresh Gas Flow Meter [part of flow meter bezel assembly 4116543 (3-gas) or 4116542 (2-gas)]	
1.	Flowmeter tube assembly (incl. brackets and mounting nuts)	4116950
2.	Luer fitting	M30960
3.	Collar, 6 mm white	M31603

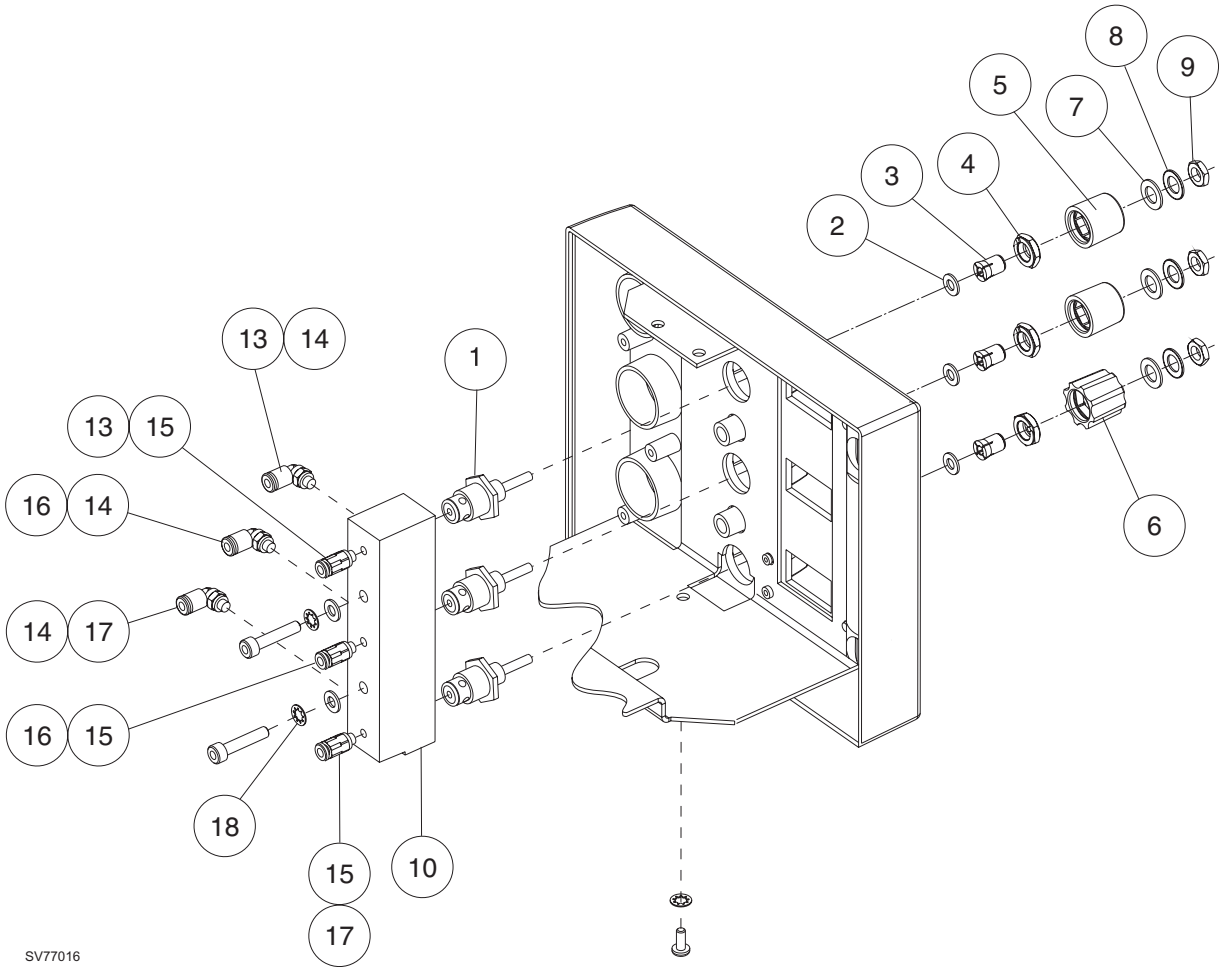

SV77016

FABIUS GS	SPARE AND REPLACEMENT PARTS (continued)
------------------	--

ITEM	DESCRIPTION	PART NUMBER
------	-------------	-------------

Flow control valves and valve manifold

[part of flow meter bezel assembly 4116543 (3-gas) or 4116542 (2-gas)]

- | | | |
|-----|-----------------------------------|-------------|
| 1. | Flow control valve (3x) | 4116984 |
| 2. | Spacer (3x) | 4110792-054 |
| 3. | Collet (3x) | 4116969 |
| 4. | Chuck (3x) | 2600308 |
| 5. | Knob, N2O & Air (2x) | M24452 |
| 6. | Knob, O2 | M24900 |
| 7. | Washer, DIN 1751 (3x) | M19190 |
| 8. | Spring washer (3x) | M24963 |
| 9. | Nut (3x) | 2600305 |
| | | |
| 10. | Manifold | 4116988 |
| 11. | Deleted | |
| 12. | Deleted | |
| 13. | Washer, 4 mm blue | M30937 |
| 14. | Angle connector | M30953 |
| 15. | Straight connector, M5 | M30952 |
| 16. | Ferrule, pilot to Divan | M30963 |
| 17. | Washer, M4 white | M31602 |
| 18. | Deleted | |

Knob caps part numbers:

Country	O2		Air		N2O	
	Color	P/N	Color	P/N	Color	P/N
Germany, Austria	Black	M34305	Black	M34307	Black	M34306
USA	Green	M25147	Yellow	M25797	Blue	M24901
France, Spain, UK/Ireland	White	4115657	Blk/wh	M26205	Blue	M24901

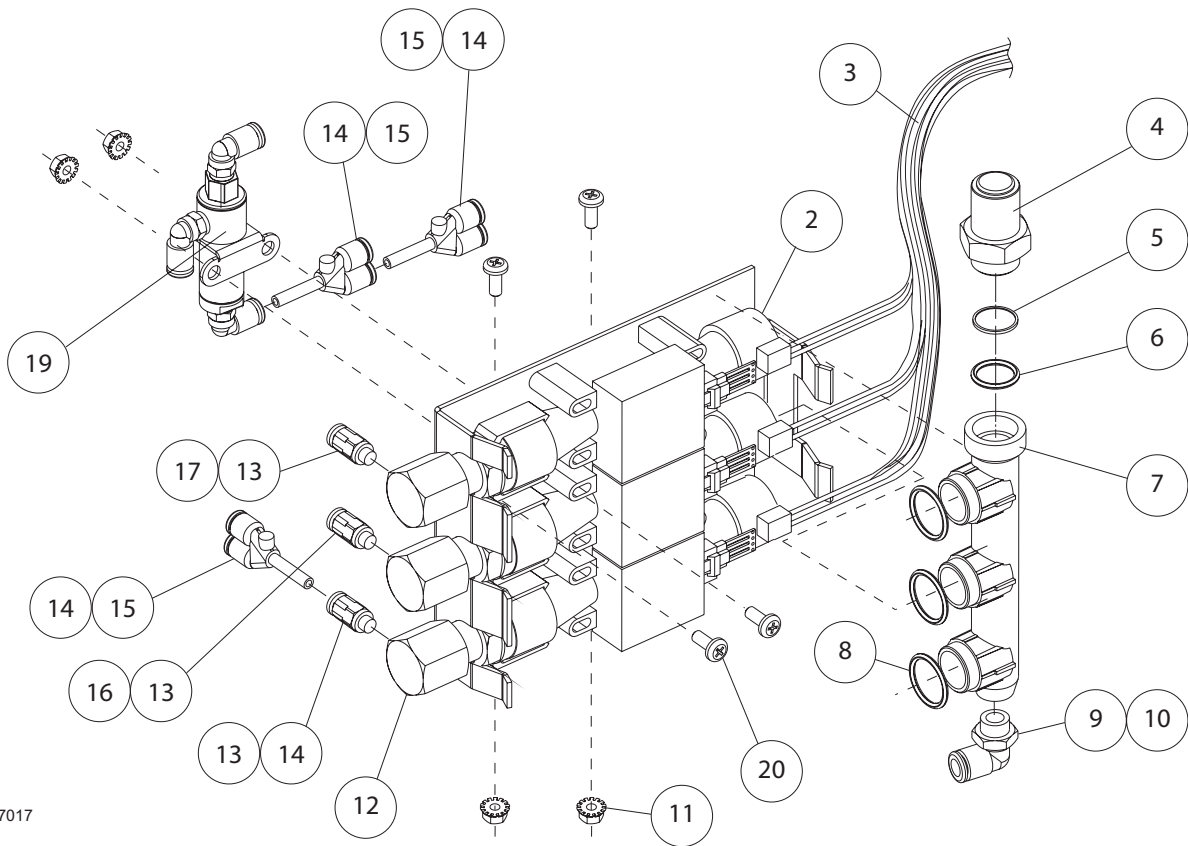

SV77017

CONFIGURATION OF FRESH GAS FLOW SENSORS AND FILTER ASSEMBLY
FOR FABIUS GS MACHINES WITH SERIAL NUMBERS 12191 AND LOWER

FABIUS GS	SPARE AND REPLACEMENT PARTS (continued)
------------------	--

ITEM	DESCRIPTION	PART NUMBER
	Fresh gas flow sensors and filter assembly (Fabius GS Machines with Serial Numbers of 12191 and lower) [part of flow meter bezel assembly 4116543 (3-gas) or 4116542 (2-gas)]	
1.	Deleted	
2.	Flow sensor assembly (3x) (w/o angle connector (12) and O-ring (8))	4116938
3.	Cable assembly, gas flow sensor	4117066
4.	Safety valve	4115950
5.	O-ring, #113 (silicone)	4107961
6.	Filter assembly	M16201
7.	Flow sensor manifold, 3-gas	4116978
	Flow sensor manifold, 2-gas	4116978-001
	Alternate part number	4199937
8.	O-ring, #106 (neoprene) (3x)	4109322
9.	Collar, 6 mm white	M31603
10.	Angle connector, M5	M30961
11.	Kep nut, M5 (2x)	HW55013
12.	Angle adapter, 1/4 MPT to M5 (3x)	4116986
13.	Straight connector, M5	M30952
14.	Washer, M4 white	M31602
15.	Y-plug	M30962
16.	Ferrule, Pilot to Divan	M30963
17.	Washer, 4 mm blue	M30937
18.	Deleted	
19.	Input valve, complete	4117293
20.	Screw, M4 x 8 (2x)	1340778
21.	Deleted	

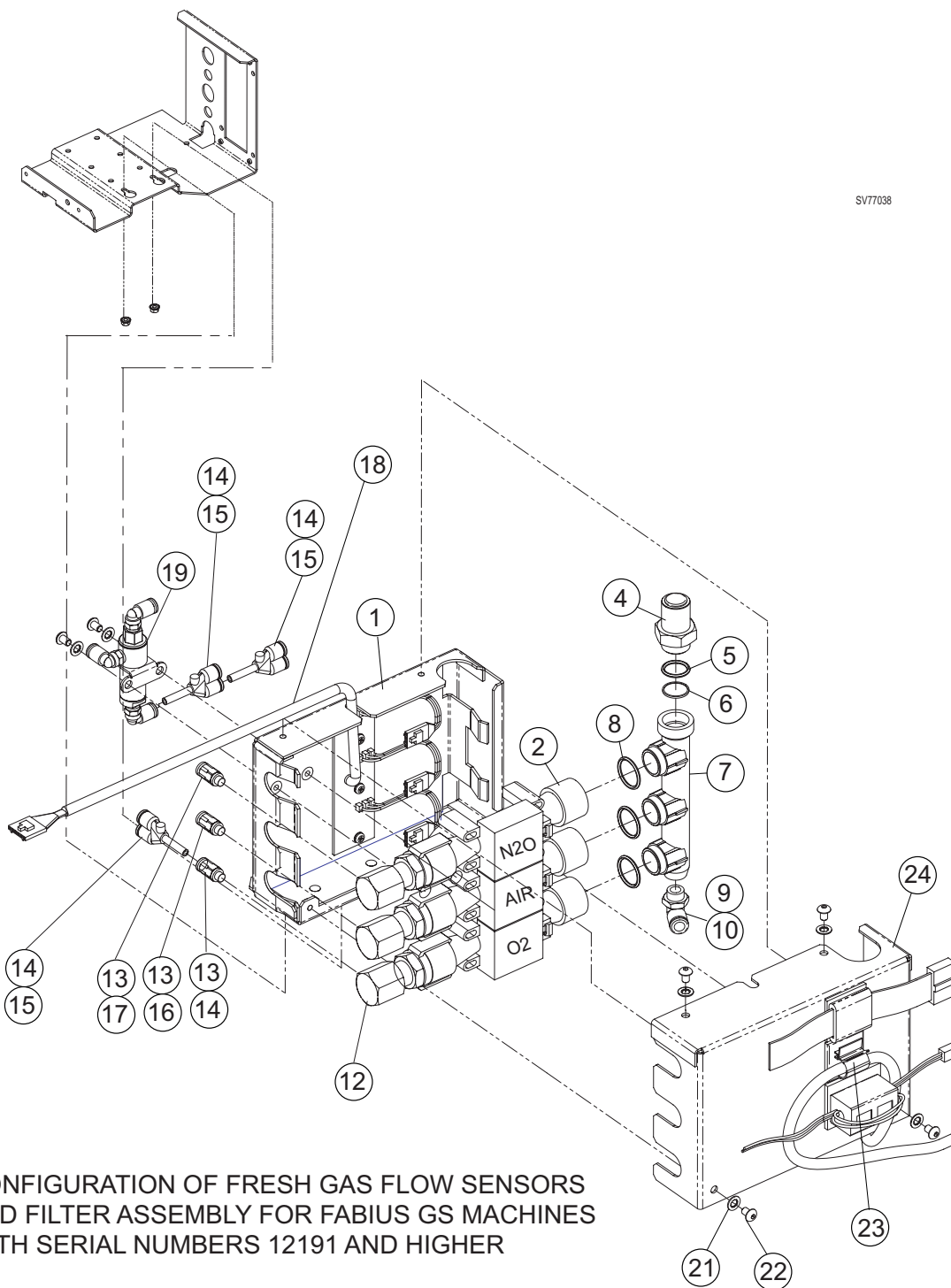

ITEM	DESCRIPTION	PART NUMBER
Fresh gas flow sensors and filter assembly (Fabius GS Machines with Serial Numbers of 12191 and higher)		
[part of flow meter bezel assembly 4116543 (3-gas) or 4116542 (2-gas)]		
1.	Flow sensor housing	4118279
2.	Flow sensor assembly (3x) (w/o angle connector (12) and O-ring (8))	4116938
3.	Cable assembly, gas flow sensor	4117066
4.	Safety valve.	4115950
5.	O-ring, #113 (silicone).	4107961
6.	Filter assembly	M16201
7.	Flow sensor manifold, 3-gas.	4116978
	Flow sensor manifold, 2-gas.	4116978-001
	Alternate part number.	4199937
8.	O-ring, #106 (neoprene) (3x)	4109322
9.	Collar, 6 mm white	M31603
10.	Angle connector, M5	M30961
11.	Kep nut, M5 (2x).	HW55013
12.	Angle adapter, 1/4 MPT to M5 (3x)	4116986
13.	Straight connector, M5.	M30952
14.	Washer, M4 white	M31602
15.	Y-plug	M30962
16.	Ferrule, Pilot to Divan	M30963
17.	Washer, 4 mm blue	M30937
18.	Cable Assembly, Gas Flow Sensor	4118281
19.	Input valve, complete.	4117293
20.	Screw, M4 x 8 (2x).	1340778
21.	Washer, Lock (6X).	HW06700
22.	Screw, Button Head (6X)	HW09110
23.	Clip, Power Cable	4107047
24.	Flow Sensor Housing Cover.	4118280

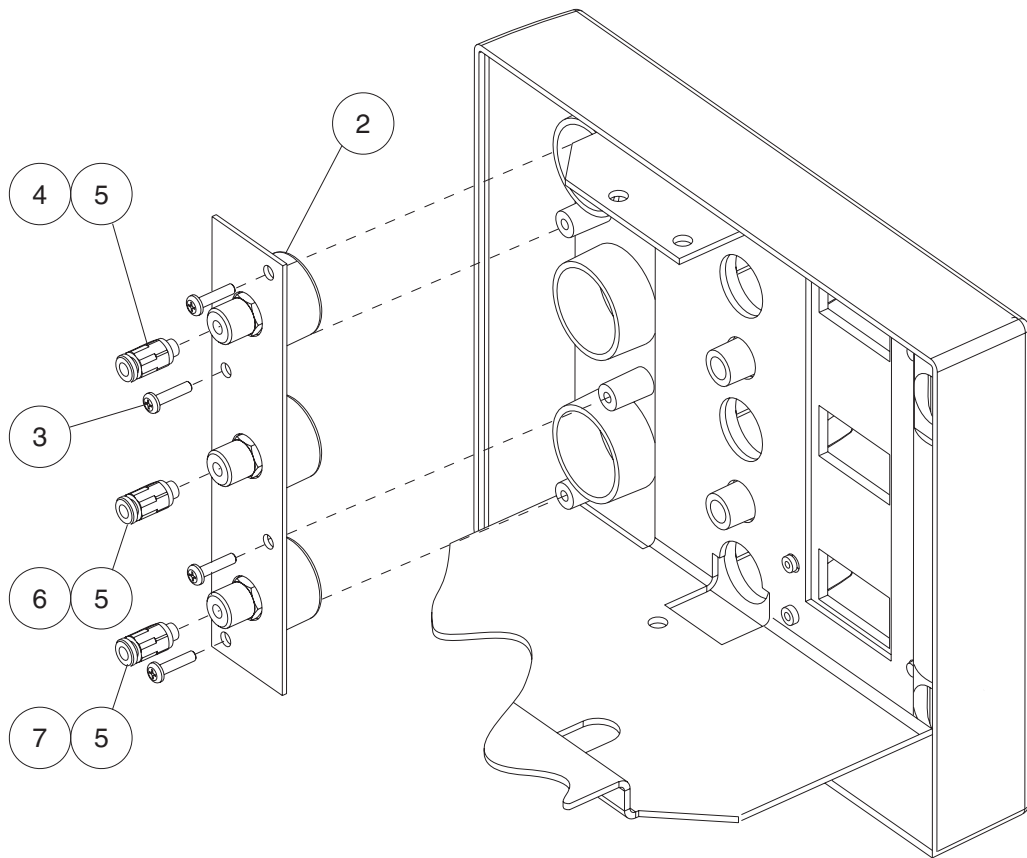

SV77018

FABIUS GS	SPARE AND REPLACEMENT PARTS (continued)
------------------	--

ITEM	DESCRIPTION	PART NUMBER
------	-------------	-------------

Pipeline pressure gauges

[part of flow meter bezel assembly 4116543 (3-gas) or 4116542 (2-gas)]

- | | | |
|----|---|---------|
| 1. | Deleted | |
| 2. | Pipeline pressure gauge (3x) | 4117144 |
| 3. | Screw, M4 x 12 mm self tap (4x) | 4117021 |
| 4. | Washer, 4 mm blue | M30937 |
| 5. | Straight connector, M5 | M30952 |
| 6. | Ferrule, pilot to Divan | M30963 |
| 7. | Washer, M4 white | M31602 |

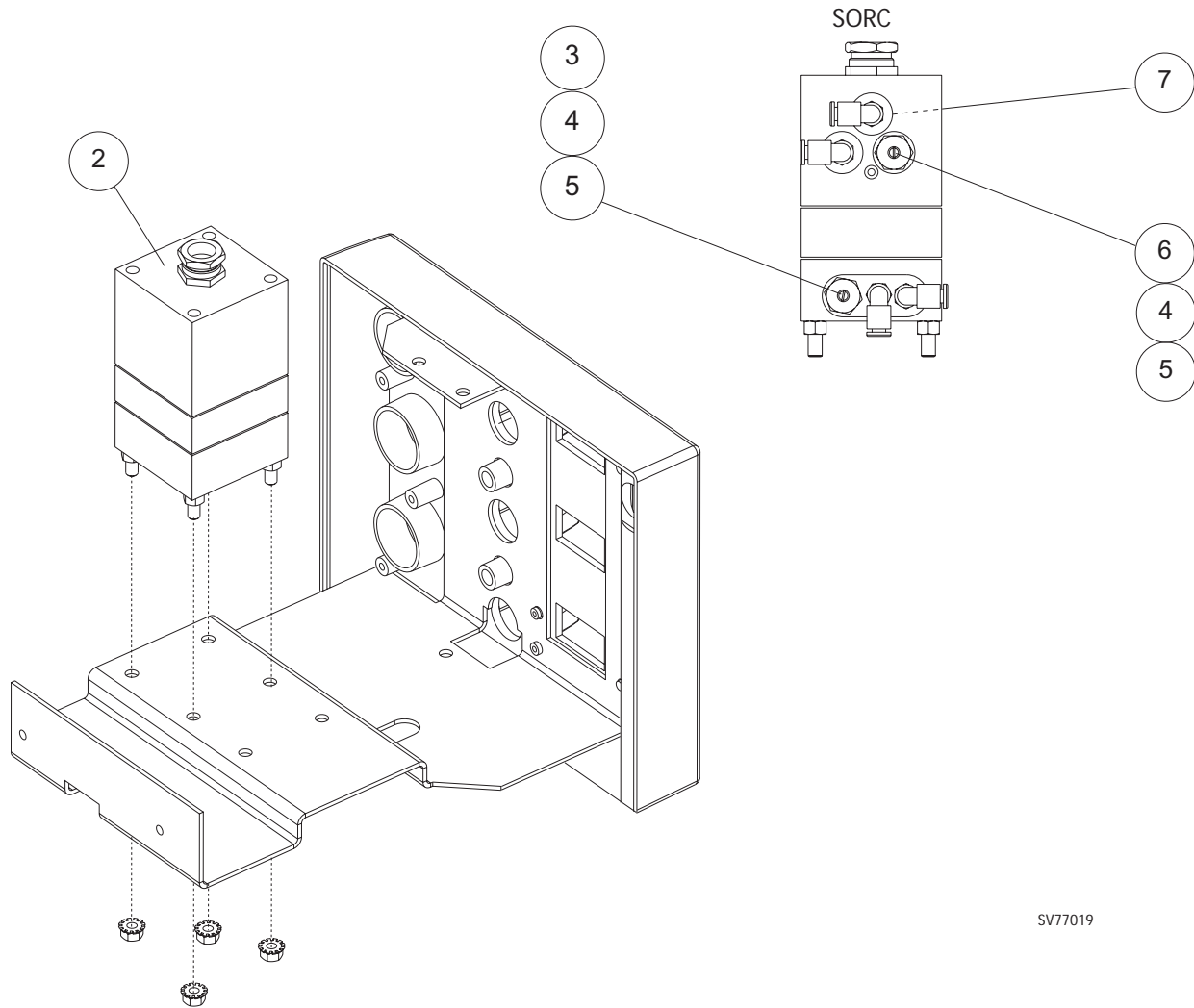

FABIUS GS	SPARE AND REPLACEMENT PARTS (continued)
------------------	--

ITEM	DESCRIPTION	PART NUMBER
------	-------------	-------------

SORC

[part of flow meter bezel assembly 4116543 (3-gas) or 4116542 (2-gas)]

- | | | |
|----|---------------------------------|--------|
| 1. | Deleted | |
| 2. | SORC (proportional valve) | M32940 |
| 3. | Resistor, O2 red | M27543 |
| 4. | O-ring | E20274 |
| 5. | O-ring, DIN 3771 | M30308 |
| 6. | Resistor, N2O blue | M27539 |
| 7. | Filter (inside unit) | M32922 |

SV77020

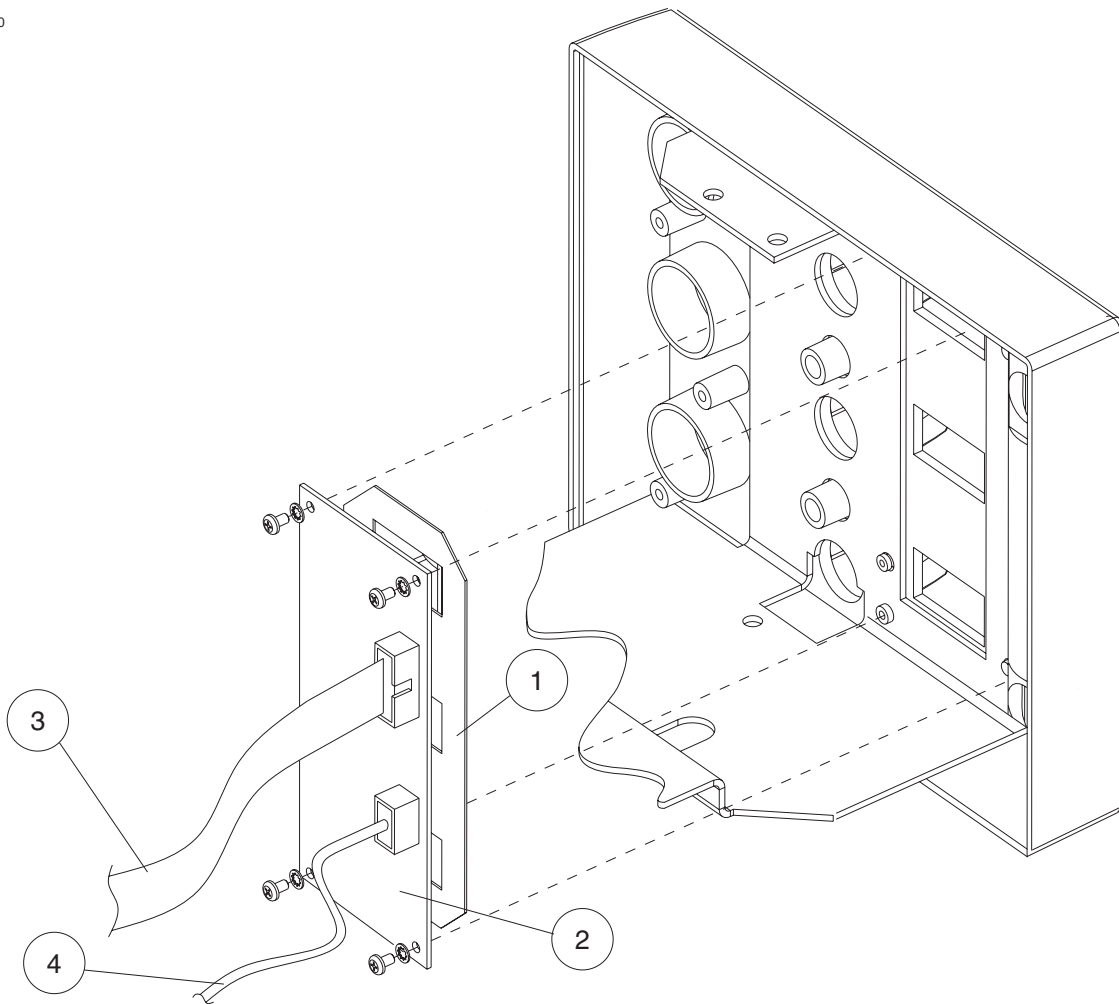

FABIUS GS	SPARE AND REPLACEMENT PARTS (continued)
------------------	--

ITEM	DESCRIPTION	PART NUMBER
------	-------------	-------------

Fresh gas display PCB

[part of flow meter bezel assembly 4116543 (3-gas) or 4116542 (2-gas)]

- | | | |
|----|---|-------------|
| 1. | Insulator, flowmeter display | 4116965 |
| 2. | PCB assembly, fresh gas display | 4116623 |
| 3. | Cable assembly, Display | 4112149-009 |
| 4. | Cable assembly, O2 pressure | 4117054 |
| 5. | Deleted | |
| 6. | Deleted | |

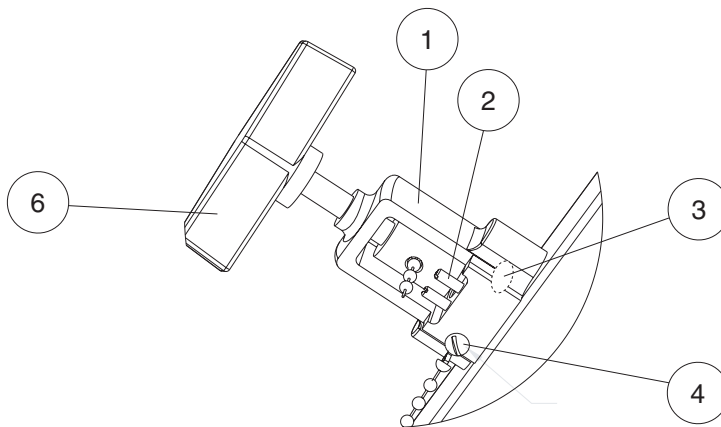
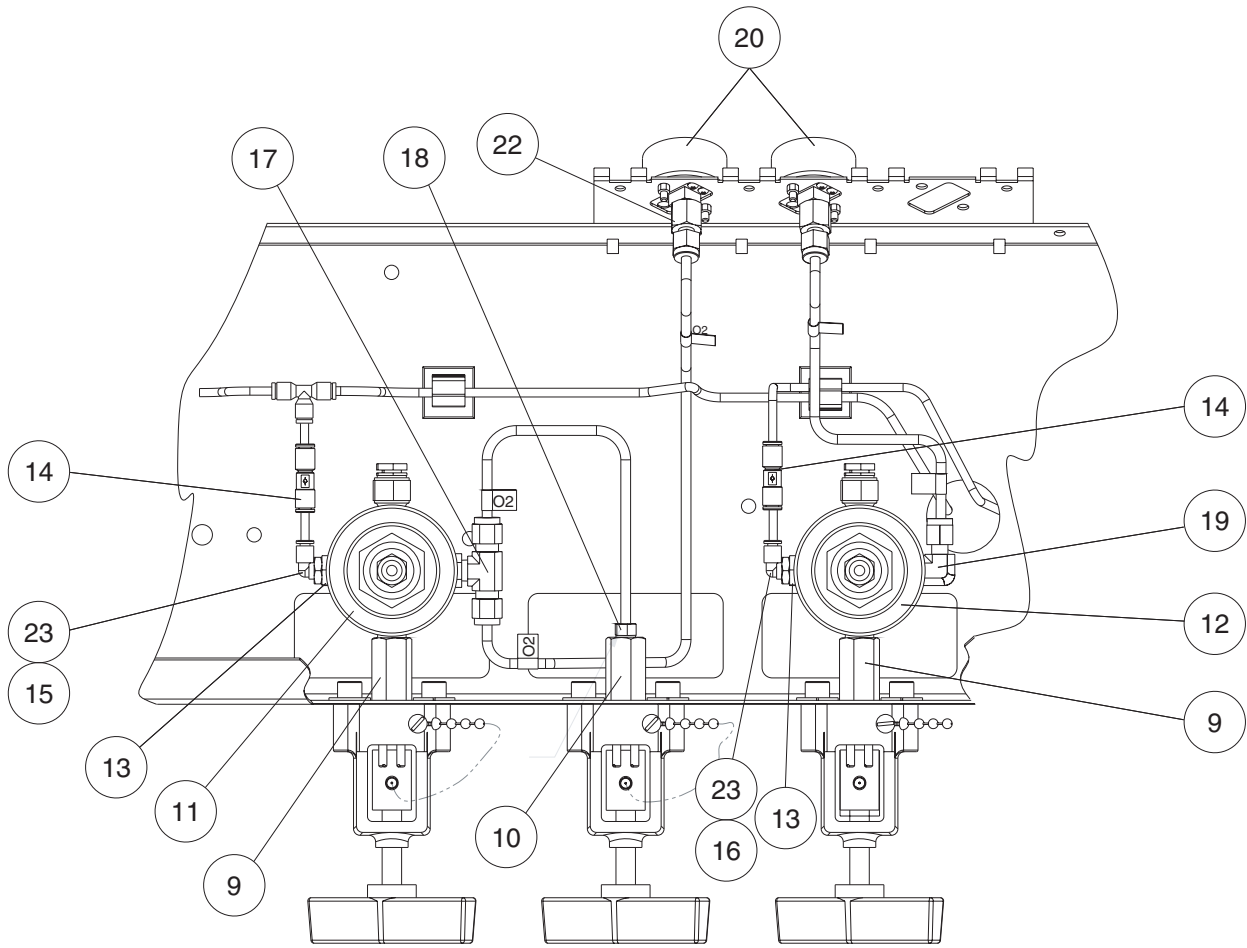

SV77021

FABIUS GS	SPARE AND REPLACEMENT PARTS (continued)
------------------	--

ITEM	DESCRIPTION	PART NUMBER
------	-------------	-------------

Cylinder Yokes, Regulators, and Gauges:

1.	O2 yoke (2x)	1101620
	N2O yoke.	1101621
	Air yoke	1101625
2.	Index pin - screw, sltd 0.157 OD 6-32 x 0.718 L (2x per yoke)	4105929
3.	Label, 3/8 DOT O2	4111266-007
	Alternate part number	4199935
	Label, 3/8 DOT N2O	4111266-008
	Alternate part number	4199934
	Label, 3/8 DOT Air	4111237-004
	Alternate part number	4199930
4.	Screw, 10-32 x 3/8 rd hd	HW06006
5.	Deleted	
6.	Yoke handle	4113536
7.	Deleted	
8.	Deleted	
9.	Check valve assembly (2x)	4113932-001
	Alternate part number	4199943
10.	Check valve assembly	4111792
11.	O2 cylinder pressure regulator, 36 psi	4117244
12.	N2O cylinder pressure regulator, 36 psi	4117245
13.	Straight fitting, 1/4 MPT x 1/8 FPT (2x)	4102906
14.	Check valve (2x)	4117686
15.	Washer, 4 mm white	M31602
16.	Washer, 4 mm blue	M30937
17.	T-fitting, 3/16 tube x 3/16 tube x 1/8 MPT	4109404
18.	Nut, 3/16 tube	4104716
19.	L-fitting, 3/16 tube x 1/4 MPT	4109409-001
	Alternate part number	4199928
20.	Cylinder pressure gauge, 3000 psi, NMM (2x)	4114247-002
	Alternate part number	4199944
21.	Deleted	
22.	Straight fitting, 3/16 tube x 1/8 FT (2x)	4109402
23.	Angle Connector, M5	M30961

SV77022

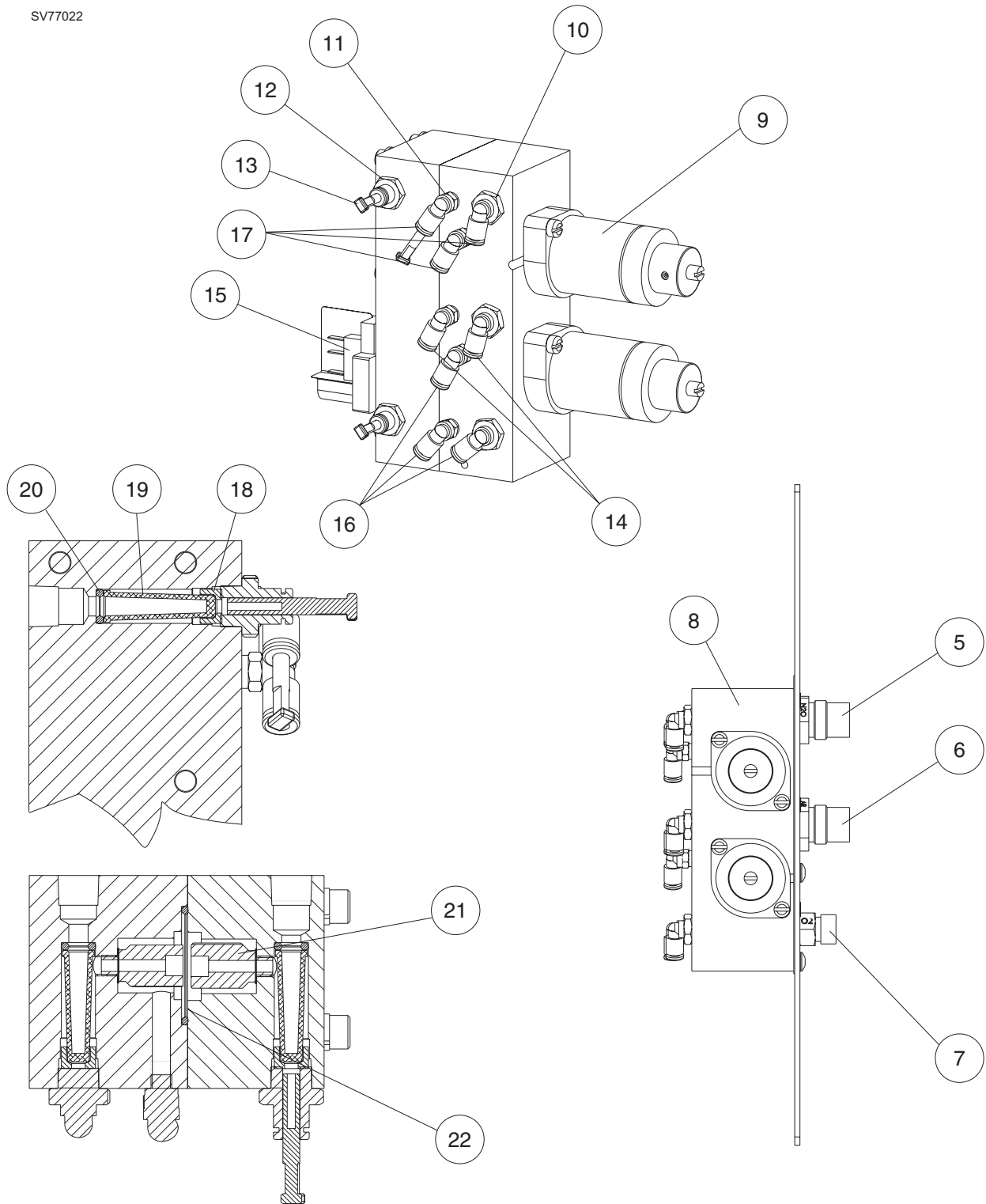

ITEM	DESCRIPTION	PART NUMBER
1.	Deleted	
2.	Deleted	
3.	Deleted	
4.	Deleted	
5.	Connector, NIST N2O male	4111382
	Connector, DISS N2O	4111384
6.	Connector, NIST Air male	4110386
	Connector, DISS Air	4102886
7.	Connector, NIST O2 male	4110388
	Connector, DISS O2	4102563
8.	Gas Inlet assembly, 3-gas/5 connector	4116537
	Gas Inlet assembly, 3-gas/3 connector	4116538
9.	Inlet regulator (2x)	4116946
10.	90 deg connector G 1/8 (3x)	M30935
11.	Angle connector (5x)	M30953
12.	Fitting, pilot to Divan (2x)	M28816
13.	Contact 04 mm (3x) (1x for 3-gas/3 connector asm)	M31348
14.	Ferrule, Pilot to Divan (2x)	M30963
15.	Pressure switch, O2 supply	4117143
16.	Washer, M4 white (3x)	M31602
17.	Washer, M4 blue (3x)	M30937
18.	Filter holder (5x) (3x for 3-gas/3 connector asm)	4116942
19.	Filter (5x) (3x for 3-gas/3 connector asm)	4102532
20.	O-ring, #008 (EPDM) (5x) (3x for 3-gas/3 connector asm)	4115960
21.	Check valve (5x) (3x for 3-gas/3 connector asm)	4117759
22.	O-ring, #022 (Viton) (3x)	4101882
23.	Deleted	
24.	Deleted	
Related parts (not shown):		
	Hose, 2.7 x 0.65 PAE, black/white	1210181
	Hose, 2.7 x 0.65 PAE, white	1210157
	Hose, 2.7 x 0.65 PAE, blue	1210211

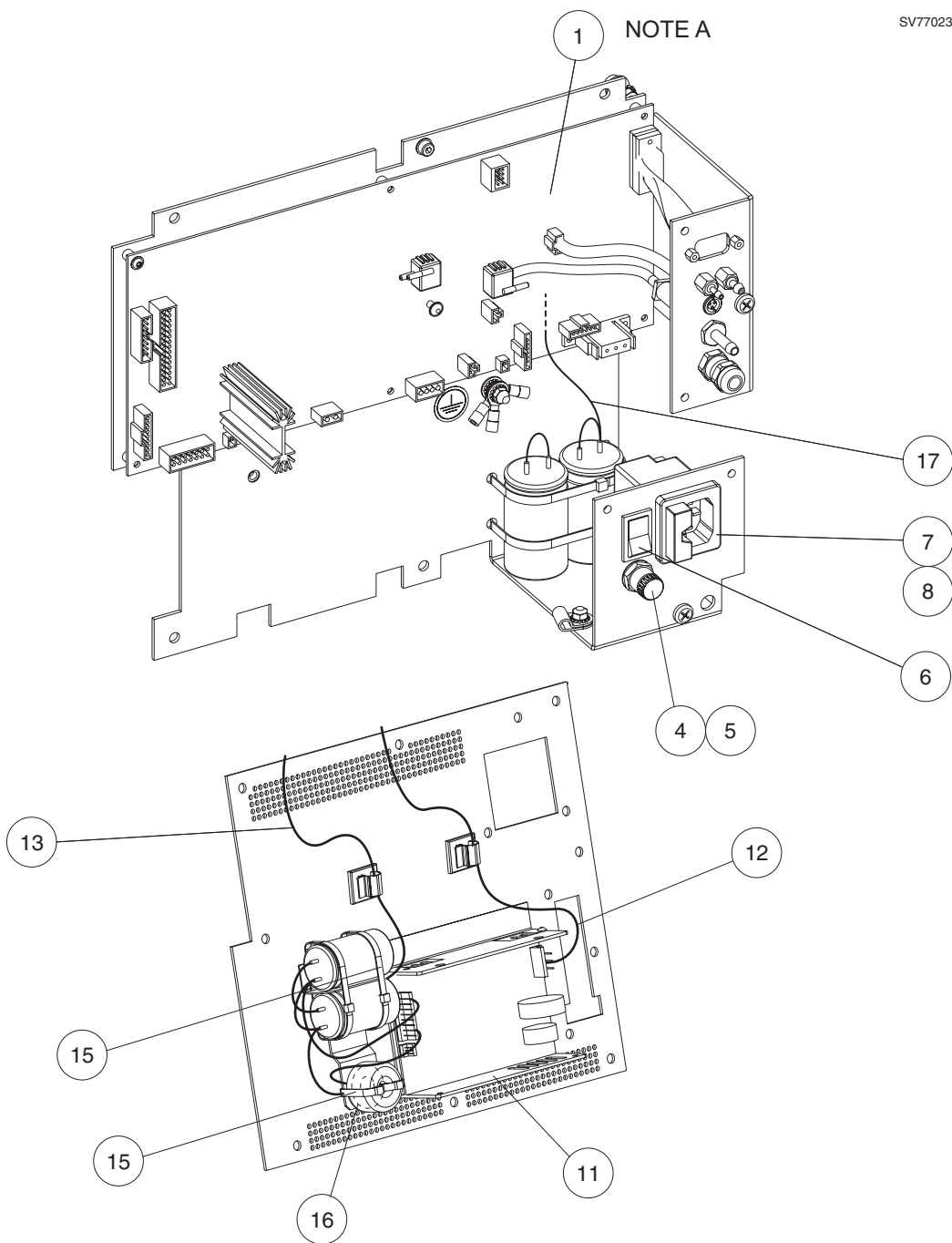

NOTE A: CONFIGURATION SHOWN IN ILLUSTRATION IS BASED UPON CONTROL PCB P/N 4116632. THE CONFIGURATION OF CONTROL PCB P/N 4118079 WILL DIFFER.

FABIUS GS	SPARE AND REPLACEMENT PARTS (continued)
------------------	--

ITEM	DESCRIPTION	PART NUMBER
1.	PCB assembly, Service Exchange	SE4116632
	Alternate part number	4199927

NOTE: The SE4116632 Control PCB is not interchangeable in a unit originally configured with a 4118079 Control PCB.

PCB assembly, Service Exchange (for use only with Software Version \geq 2.X) . SE4118079

NOTE: Replacement PCBs may contain a previous software version. Therefore, a software update may be necessary after installation. If applicable, perform the Software Update Procedure outlined in Section 8 with the appropriate level software. Refer to applicable Technical Service Bulletins for details.

Fuse, 5 x 20 mm time lag, 1.6 A	EC01200-001
Alternate part number	4199955

NOTE: The following fuses are used only on PBC assembly SE4116632 and 4199927:

Fuse, 5 x 20 mm time lag, 2.5 A	EC01200-002
Alternate part number	4199954
Fuse, 5 x 20 mm time lag, 4.0 A	EC01200-004
Alternate part number	4199952

2.	Deleted	
3.	Deleted	
4.	Fuse Holder	1832662
5.	Fuse, 5 x 20 mm time lag, 3.15 A	EC01200-003
	Alternate part number	4199953
6.	Cable assembly, power switch	4117053
7.	Power inlet & mains fuse holder	4117013-001
8.	Fuse, 5 x 20 mm time lag, 2.5 A (2x)	EC01200-002
	Alternate part number	4199954
9.	Deleted	
10.	Deleted	
11.	Power supply	4117060
12.	Cable assembly, power supply AC input	4117050-002

NOTE: (new style) Replacement of this cable may also require replacement of Power Inlet #5

13.	Cable assembly, power supply output (incl. capacitors & inductor)	4117051
	Cable assembly, power supply output (w/o capacitors & inductor) (new style)	4117051-001

NOTE: Not to be used in conjunction with Control PCB P/N 4116632 Series.

14.	Deleted	
15.	Tie strap (2x)	1101732
16.	Spacer, R	4110972-106
17.	Cable assembly, charge capacitors (incl. capacitors)	4117089

Miscellaneous Items (Not Shown)

Power cord assembly:		
	USA, 15 ft.	4117266
	UK/Ireland	4115377-001
	Alternate part number	4199926
	Spain/France/Germany/Austria	4115367-001
	Alternate part number	4199925
	Battery, 12V Rechargeable (x2)	4114229

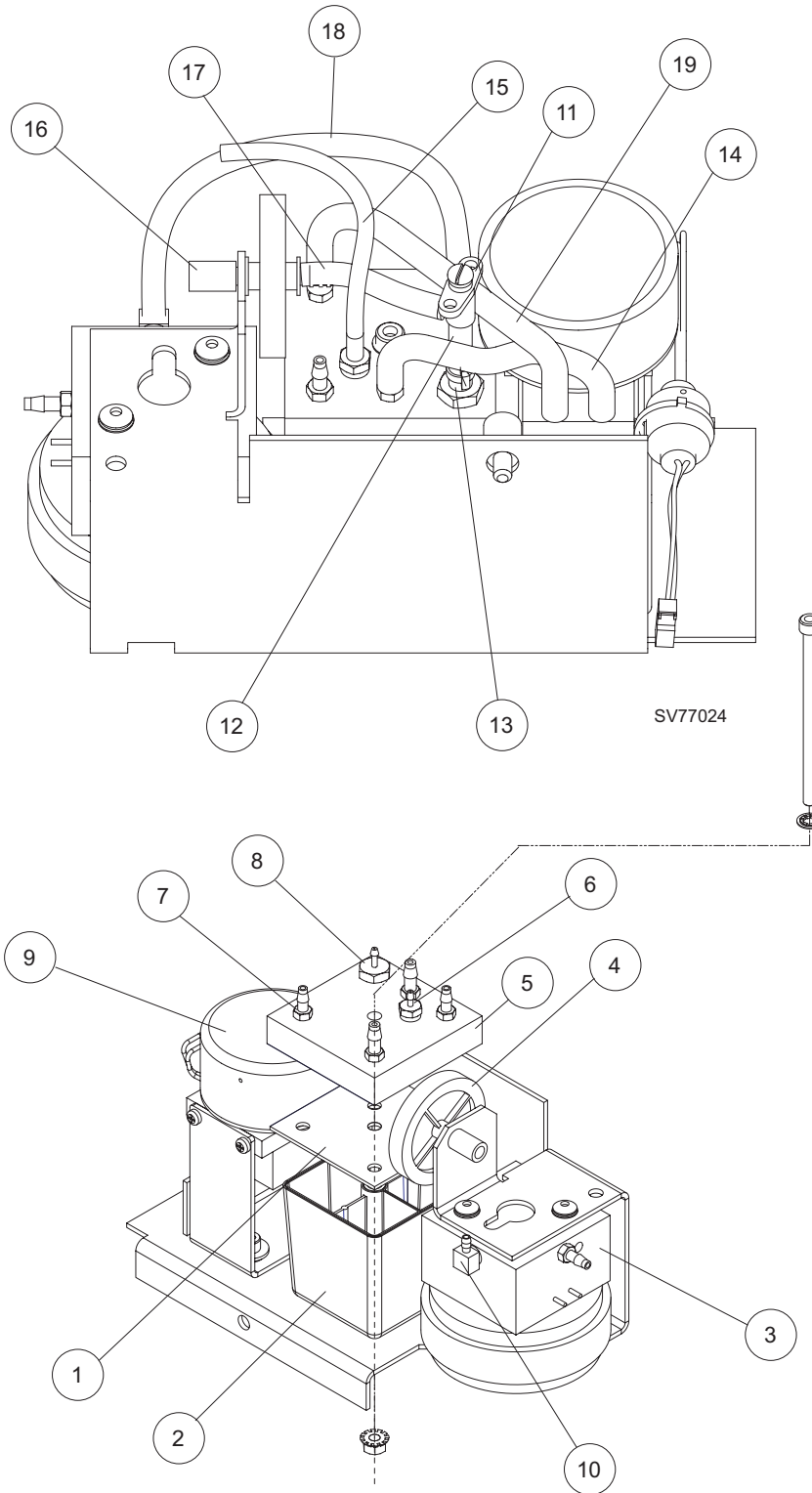

ITEM	DESCRIPTION	PART NUMBER
	Pneumatic (PEEP Control) Assembly4117004
1.	Top Gasket4116156
2.	Muffler.4116158
3.	PEEP valve assembly.	2600573
4.	Filter	8402868
5.	Top plate4116155
6.	Straight fitting, 1/16 ID x 10-32 w/seal (old style pump assembly)	4112707-001
	Alternate part number	4199924
	Straight fitting, 1/16 ID x 10-32 w/seal (new style pump assembly).	4114732-001
7.	Straight fitting, 3/32 ID hose x 10-32M (4x).4114732
8.	Adapter fitting for 1/16 ID hose x 1/8 MPT.4111446
9.	Pump assembly (Illustrated)	2600564
	Pump assembly (new style)4118160
	NOTE: Verify pump style for direct replacement from original.	
10.	L-fitting, 3/32 ID hose x 10-32M (old style pump assembly)4114733
	L-Fitting, 3/32 ID hose x 10-32M (new style pump assembly).4117971
11.	Variable restrictor.	4107995
12.	Hose, 2.5 x 2 SI (0.025 M)4115747
13.	Tie strap, 0.09 x 4 1/8	4106068
14.	Hose, 2.5 x 2 SI (0.127 M)4115747
15.	Hose, natural, 0.075 ID x 0.030 W (0.178 M) (old style pump assembly)ML08003
	Hose, 4 x 1.5 SI NF clear (0.178M) (new style pump assembly)1190520
16.	Hose, 4 x 1.5 SI NF clear (0.012 M).1190520
17.	Hose, 2.5 x 2 SI (0.040 M)4115747
18.	Hose, 2.5 x 2 SI (0.127 M)4115747
19.	Hose, 4 x 1.5 SI NF clear (0.178 M).1190520

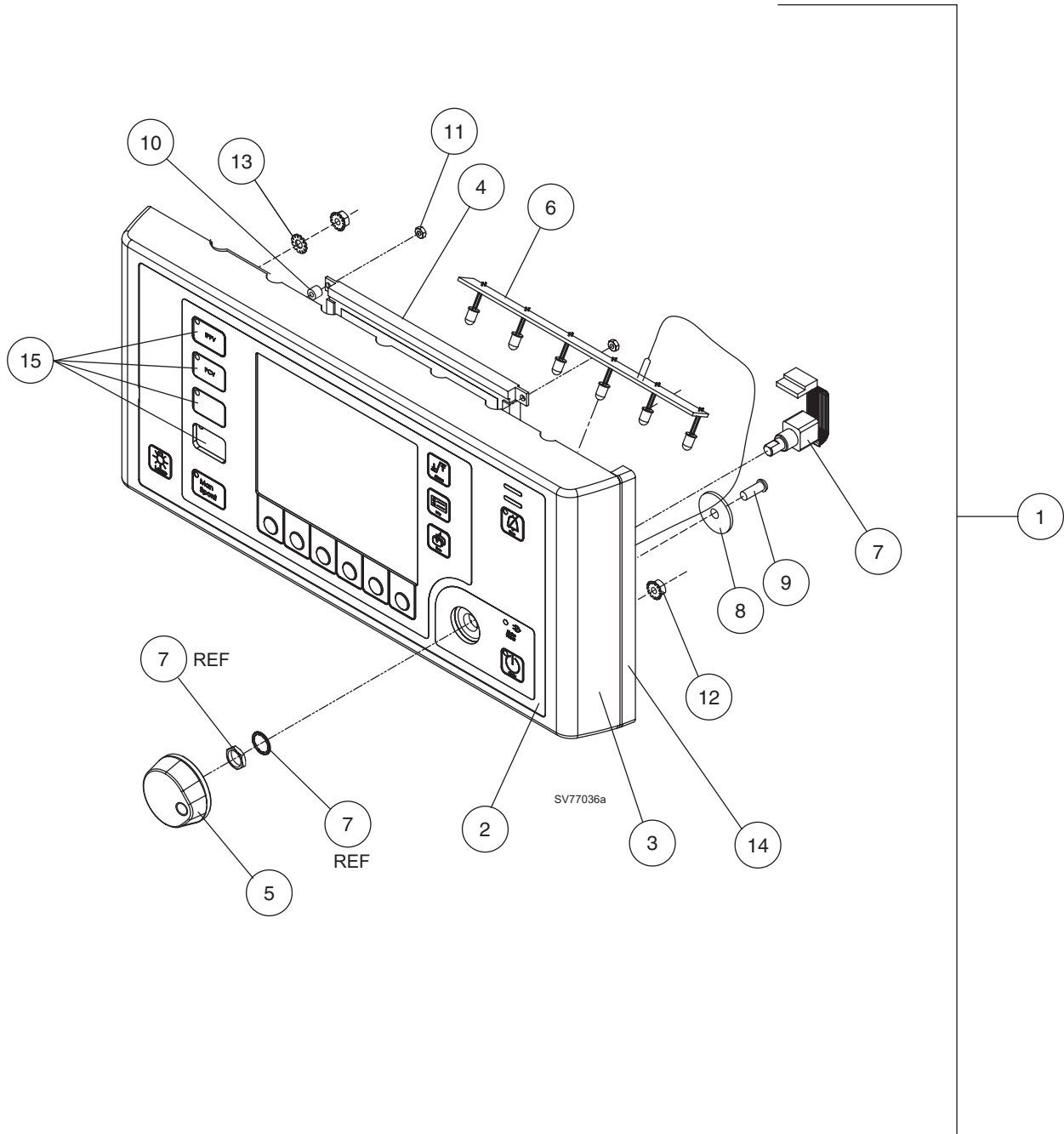

FABIUS GS	SPARE AND REPLACEMENT PARTS (continued)
------------------	--

ITEM	DESCRIPTION	PART NUMBER
1.	Bezel Assembly, Monitor	4117019
2.	Keypad (control panel) 4 Key.	4118119-001
	Alternate part number	4199863
	Keypad (control panel)	4118119-002
	Alternate part number	4199862
 NOTE: A switch panel insert may need to be ordered with replacement of the key pad or Bezel Assembly. See item #14 for the various inserts needed based on the original keypad configuration.		
3.	Bezel	4116919
4.	Flat panel display	4113755
5.	Knob	M29655
6.	LED lamp PCB assembly	4117017
7.	Rotary switch (incl. mtg. hardware)	4117012
8.	Flat washer, 0.168 ID x 0.624 OD	4117020
9.	Screw, self tap, M4 x 12 mm	4117021
10.	Spacer, 0.162 ID x 0.205 L (4x)	4113200-001
	Alternate part number	4199923
11.	Kep nut, M3 x 0.5 (4x)	HW55008
12.	Kep nut, M4 x 0.5 (5x)	HW55010
13.	Lock washer, #8 ext-t	HW68001
14.	Gasket, EMI, 0.275 x 0.080, 3.125 long	4113906-002
 Switch panel inserts:		
15.	Non-US IPPV, PCV, PS	4118120-001
	Alternate part number	4199861
	IPPV, PCV	4118120-002
	Alternate part number	4199860
	IPPV, PS.	4118120-003
	Alternate part number	4199859
	IPPV.	4118120-004
	Alternate part number	4199858
	US	
	Volume Control, Pressure Control, Pressure Support	4118120-005
	Alternate part number	4199857
	Volume Control, Pressure Control	4118120-006
	Alternate part number	4199856
	Volume Control, Pressure Support	4118120-007
	Alternate part number	4199855
	Volume Control	4118120-008
	Alternate part number	4199854
	France	
	VC, VPC, AI.	4118120-009
	Alternate part number	4199853
	VC, VPC.	4118120-010
	Alternate part number	4199852
	VC, AI	4118120-011
	Alternate part number	4199851
	VC	4118120-012
	Alternate part number	4199850

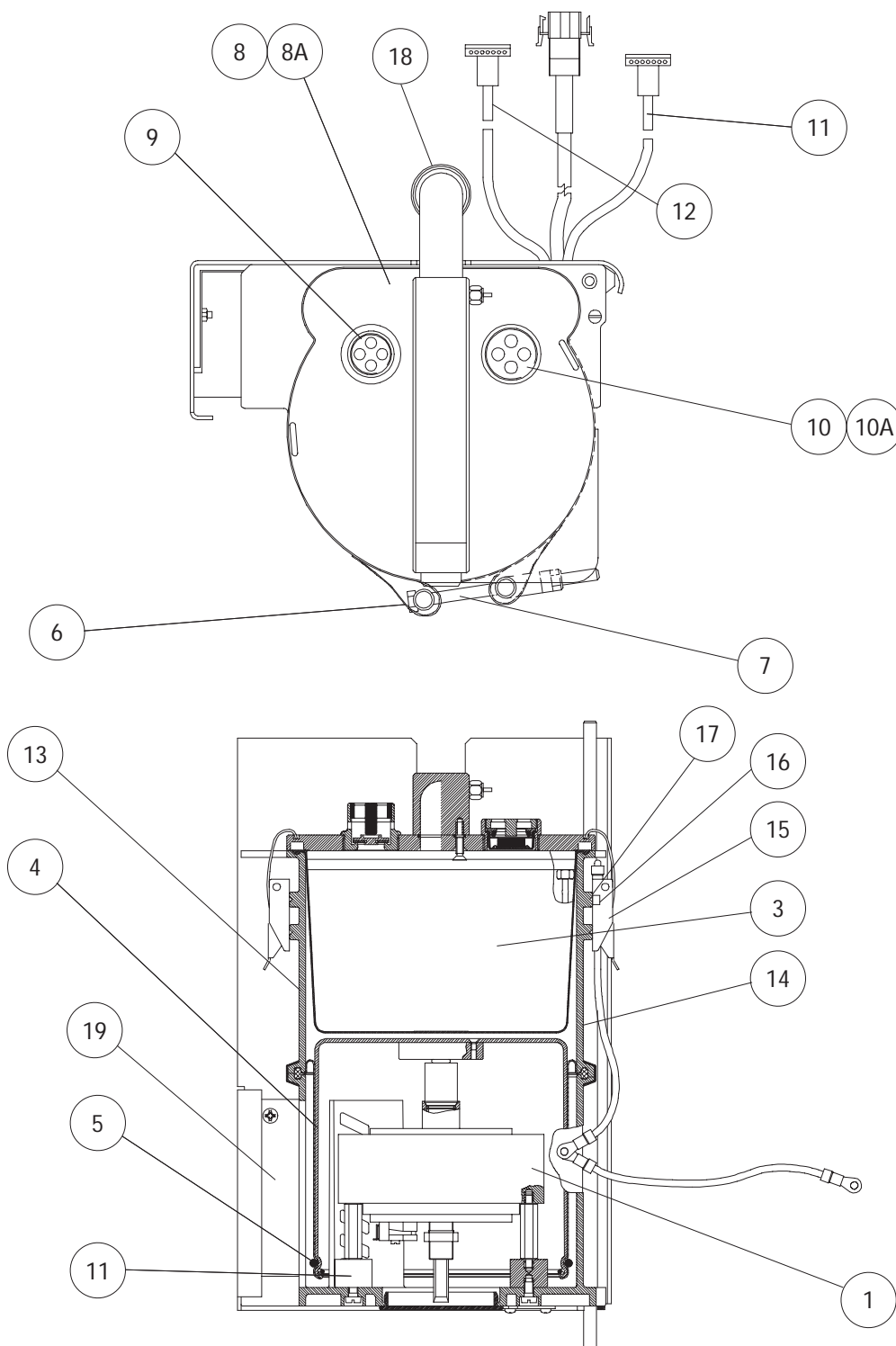

SV77025

FABIUS GS	SPARE AND REPLACEMENT PARTS (continued)
------------------	--

ITEM	DESCRIPTION	PART NUMBER
	Ventilator (w/-8 mbar pressure relief valve)	4117080-001
	Ventilator, Service Exchange (w/-8 mbar pressure relief valve)	SE4117080-001
	Alternate part number	4199791
	Ventilator, Service Exchange (w/-3 mbar pressure relief valve)	SE4117080
	Alternate part number	4199792
1.	Motor/ball screw assembly (includes encoder)	4116391-001
	Alternate part number	4199947
2.	Deleted	
3.	Diaphragm, patient side	2600650
4.	Diaphragm, piston	2600651
5.	O-ring	8604831
6.	Band clasp	2600785
7.	Screw, M6 x 80 hex hd	HW08025
8.	*Patient assembly with -3 mbar negative pressure relief valve	2600775-001
	Alternate part number	4199949
8A	*Patient assembly with -8 mbar negative pressure relief valve	2600775-003
	Alternate part number	4199890
9.	High Pressure valve	2600680
10.	*Negative Pressure Relief valve (-3 mbar)	2600670
10A	*Negative Pressure Relief valve (-8 mbar)	8604217
11.	Cable assembly, light barrier (7-pin)	4117056
12.	Cable assembly, incremter (6-pin)	4117055
13.	Dosing Cage	2600676
14.	Gear Case	2600677
15.	Rapid Fastener (x3)	2600704
16.	Screw, Pan Head, M3 x 8 - DIN 562 (x6)	1338544
17.	Washer, Flat, M3-DIN 9201 (x6)	1335359
18.	O-Ring, Vent Hose (x2)	2M08777
19.	Window - Vent	4116991

* Machine software level dictates the threshold of the negative pressure relief valve used:

Market	Software Version	-3mbar Negative Press relief valve (orange)	-8mbar Negative Press relief valve (black)	Patient Asm
US	1.20	2600670	X	2600775-001
US	≥1.3x	X	8604217	2600775-003
Non-US	1.20	2600670	X	2600775-001
Non-US	1.2x	X	8604217	2600775-003

SV00453

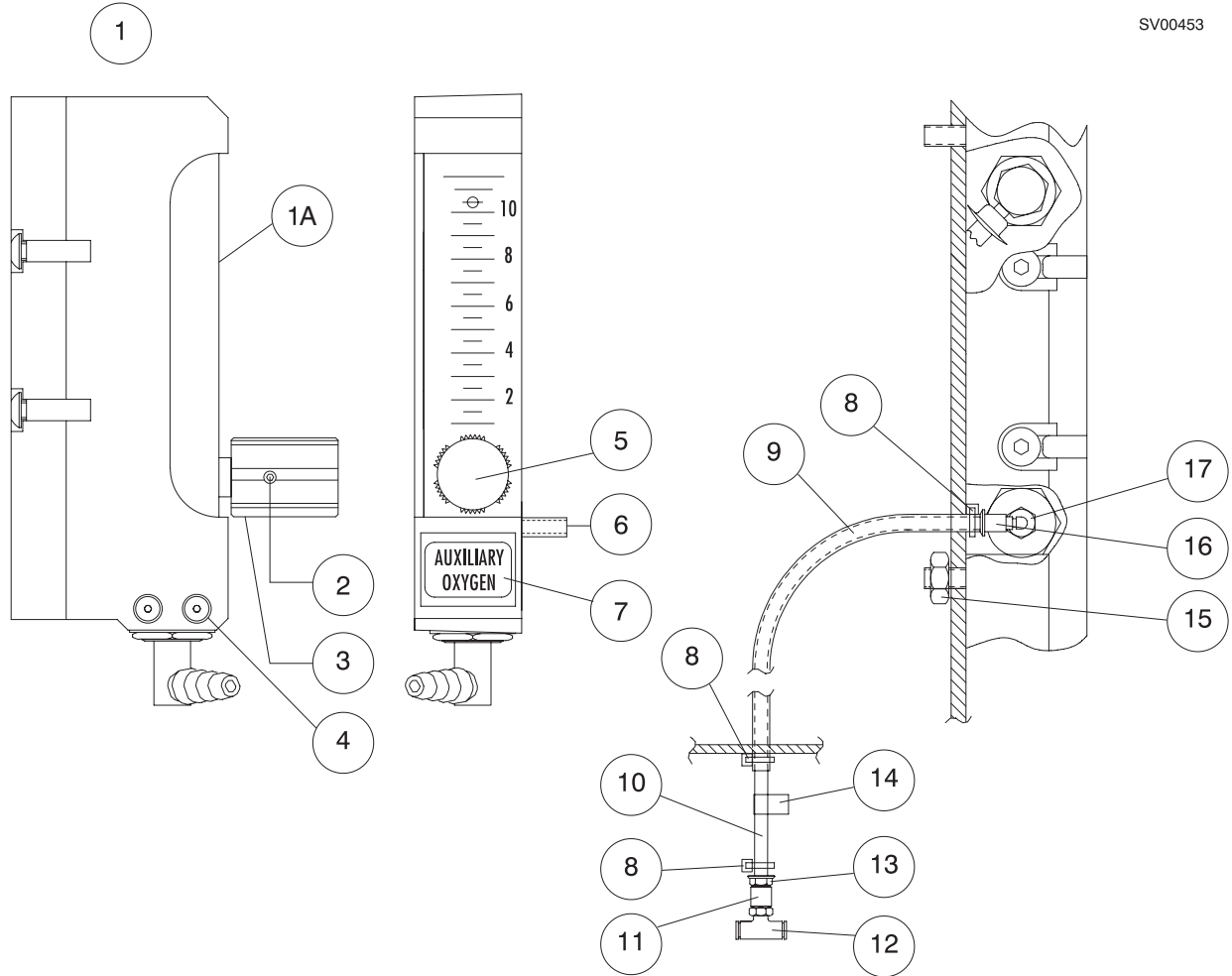

FABIUS GS	SPARE AND REPLACEMENT PARTS (continued)
------------------	--

ITEM	DESCRIPTION	PART NUMBER
1.	Auxiliary O2 Flow Meter, USA, complete	4109310-003
	Auxiliary O2 Flow Meter, ISO	4109310-004
	Alternate part number	4199906
1A	Auxiliary O2 Flow Meter, Global (flowmeter and valve asm)	4117687
2.	Set screw, cup pt 6-32 x ¼ in.	HW04003
3.	Knob, auxiliary oxygen.	4111442
4.	Screw, btn hd skt 6-32 x ¼ in. (2x).	HW09004
5.	Label, 5/8 DOT - green/wht rings (USA)	4109373
	Label, 5/8 DOT - white (ISO)	4105981
6.	Set screw, cup pt 10-32 x 7/8 in. (2x)	HW04011
7.	Label "AUXILIARY OXYGEN"	4109381
8.	Tie Strap 0.09 W x 4 1/8 L (3x)	4106068
9.	Hose, 0.171 ID x 0.040 W 20 in.	ML08006
10.	Hose, 0.075 ID x 0.030 W 24 in.	ML08003
11.	Coupling, 1/8 NPT (F).	4103668
12.	T-fitting, 1/8 BSPP x 4 mm OD	4117057
13.	Adapter, 1/16 ID hose x 1/8 MPT.	4111446
14.	Label, "O2"	4109871
15.	Kep nut, 10-32 (2x)	HW55002
16.	Hose clamp, press-on	4104161
17.	L-fitting, NY 1/16 ID hose x 10-32 M	4110173

SV77027

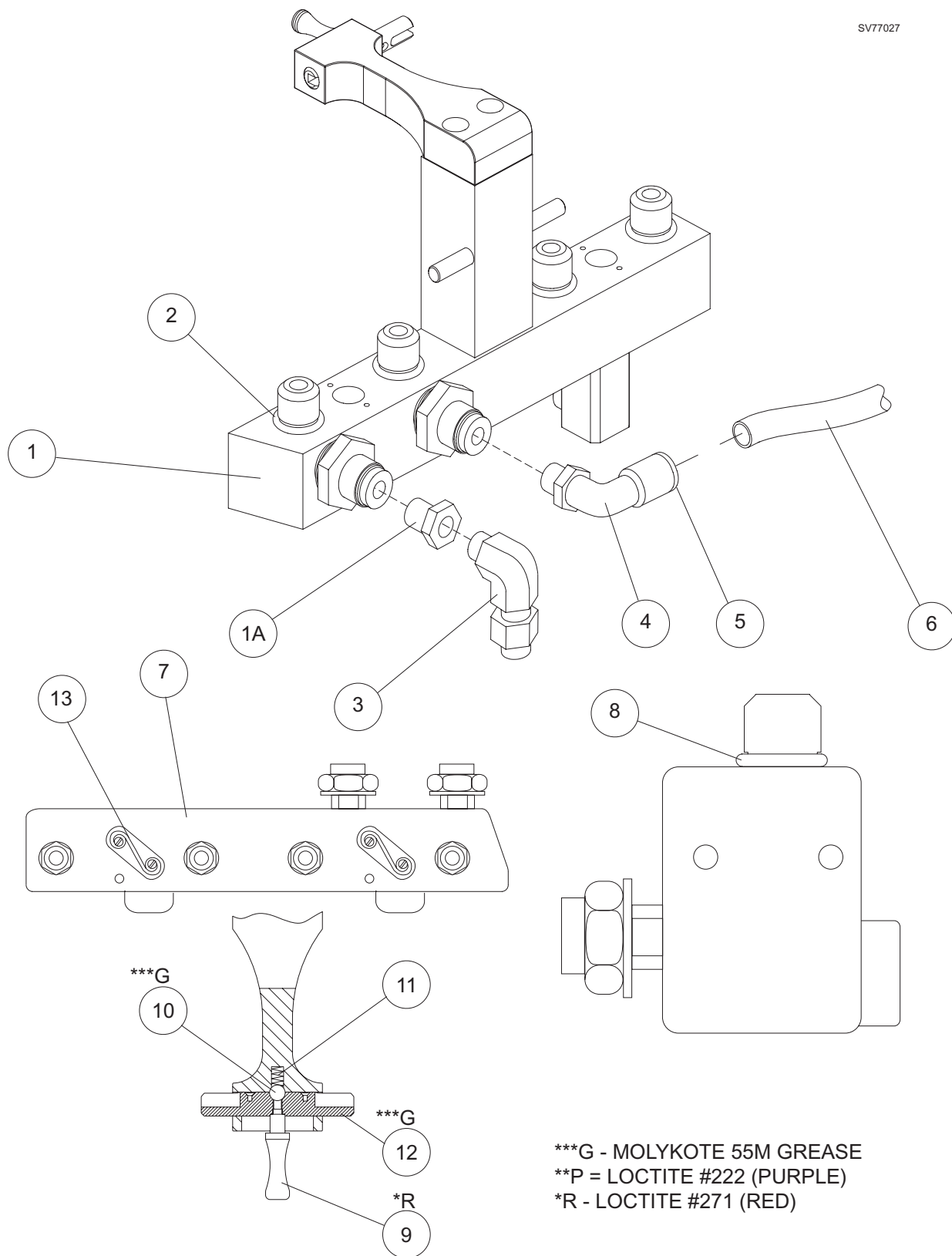

FABIUS GS	SPARE AND REPLACEMENT PARTS (continued)
------------------	--

ITEM	DESCRIPTION	PART NUMBER
1.	Two-vapor mounting system (interlock)	M34333
1A	Adapter fitting	4117690

NOTE: The adapter fitting is needed when ordering a two-vapor mounting system as a replacement part for Fabius GS units with serial numbers < 10685.

2.	O-rings, vaporizer mount (4x)	4115864
	One-vapor mounting system	4115019-007
	Alternate part number	4199931
	O-rings, vaporizer mount (2x)	4115864

Related parts:

3.	L-fitting, 1/4 tube x 1/8 MPT	4109410
4.	Angle connector, M5	M30961
5.	Collar, 6 mm white	M31603
6.	Hose, 4 mm x 1 mm, PAE NF Clear	1210173

7.	Two-vapor mounting system (Selectatec)	M35115
8.	O-ring, vapor mount (4x)	U04314
9.	Slider handle	M27143
10.	Ball, detent	1270621
11.	Spring, detent	A10594
12.	Slider	M27142
13.	Clip	M35122

Miscellaneous parts:

Loctite purple 222	4118558-001
Loctite red 271	4118558-003
Molykote 55M grease	4115127
Loctite blue 425	4118558-008
Touch-up paint: Euro white	7900380
Touch-up paint: Euro blue	7901261
Spray paint: Euro white	S000094-002
Spray paint: Euro blue	S000094-003
Silicone Adhesive (Walker-Elastosil)	1202527

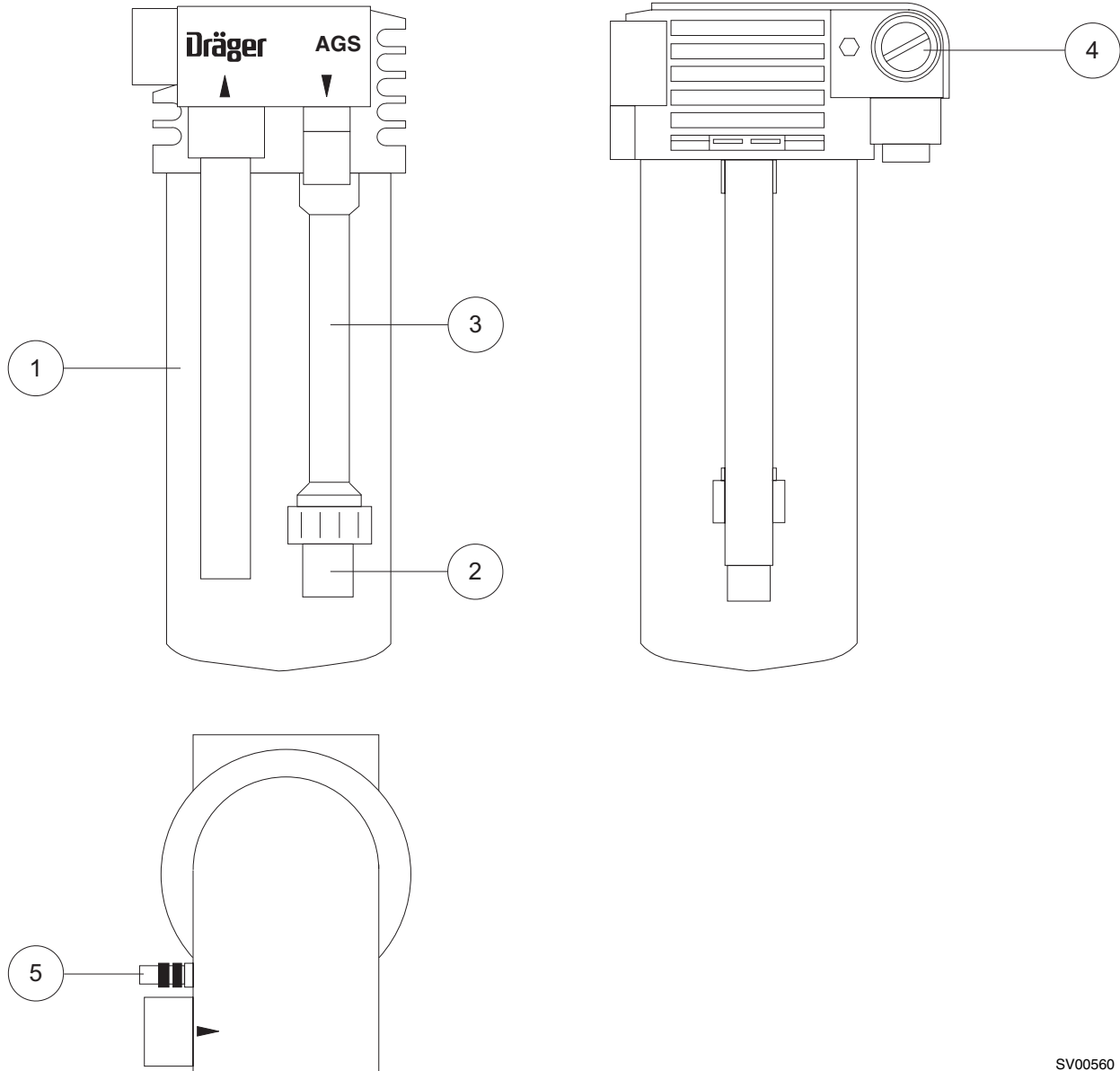

SV00560

FABIUS GS	SPARE AND REPLACEMENT PARTS (continued)
------------------	--

ITEM	DESCRIPTION	PART NUMBER
	Scavenger, AGS	M33300
1.	Container	M33292
2.	Filter	M33294
3.	Flow tube.....	M33293
4.	Screw plug.....	M33291
5.	Coupling	M33149

SV00598

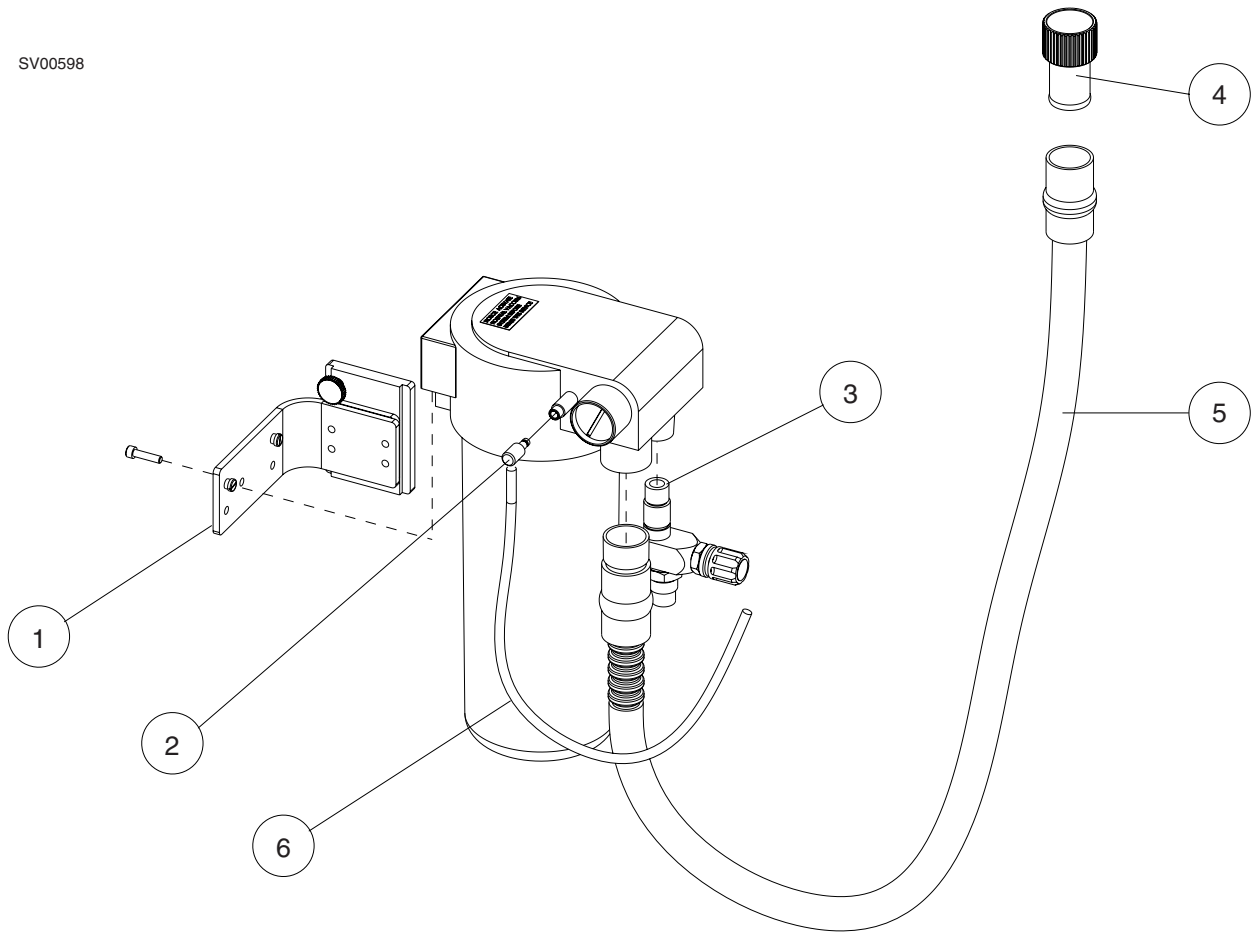

ITEM	DESCRIPTION	PART NUMBER
	AGS Scavenger w/adj valve	4117494
1.	Kit, Scavenger mount	4117515
2.	L-fitting, Q-disc adapter	M33151
3.	Metering valve	AF00539
4.	Adapter, 30 mm	M29430
5.	Hose, scavenger, 1.0 M	M33295
6.	Hose, 4 x 1.5 SI NF clear, 1.5 M	1190520

[RETURN TO THIS MANUAL'S TABLE OF CONTENTS](#)
[RETURN TO CD-ROM TABLE OF CONTENTS](#)

[RETURN TO THIS MANUAL'S TABLE OF CONTENTS](#)
[RETURN TO CD-ROM TABLE OF CONTENTS](#)

RETURN TO THIS MANUAL'S TABLE OF CONTENTS
RETURN TO CD-ROM TABLE OF CONTENTS

Drägermedical

A Dräger and Siemens Company

DrägerService is a division of
Dräger Medical, Inc.
3122 Commerce Drive
Telford, PA 18969
Tel: (215) 721-5402
(800) 543-5047
Fax: (215) 721-5784
Web: www.draegermedical.com
Printed in the U.S.A.

Fabius GS Service Manual

Rev. K summary of changes

Page	Description
Cover	Updated revision level and date
1-2	Updated Copyright date
2-15	Corrected Figure 2-14 caption
2-19	Corrected Figure 2-18 caption
2-35	Updated Figure 2-31
2-39	Updated Figure 2-34 and Table
3-2	Updated Figure 3-1
3-4	Added new Figure 3-3, renumbered subsequent figures
5-20	Changed first NOTE
5-22	Updated Figure 5-12
5-38	Added new NOTE, step 5.12.6, and sub-steps to 5.12.6, replaced Figure 5-18, added new figure 5-19 and 5-20, renumbered subsequent figures
5-57	Added first NOTE
5-58	Updated illustration
6-16	Changed Figure 6-8 caption
6-17	Changed Figure 6-9 caption
7-2	Changed P/N of Test Lung
7-3	Added /Tiro to kit description
7-5	Changed P/N of Test Lung
7-17	Changed first NOTE
7-39	Added steps 7.11.8 and 7.11.9
7-63	Changed P/N of Test Lung in step 7.21.1.3
9-2	Added items 27 and 28
9-3	Added item 28
9-5	Updated miscellaneous items
9-36	Replaced illustration
9-37	Replaced parts list
9-38	Added item 10
9-39	Updated NOTE

Rev. J summary of changes

Page	Description
------	-------------

Cover	Updated revision level and date
TOC	Updated TOC
4-1	Changed second row, second column of table
4-32	Changed NOTE, all paragraphs
4-46	Added fourth paragraph
5-33	Updated first NOTE, added second NOTE
5-34	Updated steps 5.11.13 and 5.11.14
5-37	Added new figure 5-17
5-38	Updated step 5.12.10
5-39	Changed figure 5-18 caption
6-18	Changed title of step 6.10 and step 6.10.1
7-2	Added loctite P/N's to Materials Required
7-3	Changed P/N for O-ring, Diaphragm in 1 yr. PM Kit
7-17	Added "If applicable" on title of step 7.1.2, added first NOTE
7-21	Updated steps 7.7.10 and 7.7.11
7-22	Changed first NOTE
7-34	Changed step 7.9.5.9
7-59	Changed step 7.18.2.4
7-61	Changed steps 7.20.13 and 7.20.14
8-1	Updated first paragraph and added first NOTE
8-3	Changed step 8.2.8
8-5	Changed step 8.3.3
8-6	Changed step 8.4.2
8-11	Updated steps 8.4.13, 8.4.11, and first NOTE
8-13	Updated steps 8.5.3 and 8.5.4
8-15	Updated step 8.5.12
8-16	Added new figure 8-6
9-5	Added new Alt. P/N and changed description of third part of item #9
9-6	Changed NOTE A
9-7	Added first NOTE
9-8 and 9-9	Added new figure and lister page
9-15	Added Alt. P/N for item # 1
9-20	Added S/N statement to illustration
9-21	Added S/N statement to lister
9-22 and 9-23	Added new figure and lister page
9-34	Added NOTE to illustration
9-35	Added first NOTE, changed description of SE4118079, Changed second NOTE, changed P/N of item #7 and #12, added NOTE after item #12, Added second line and NOTE after item 13
9-37	Added new style pump P/N to item #15
9-38	Updated illustration

9-39 Added new P/N's for item #15, Added first NOTE, resequenced all numbers

9-41 Updated P/N for item #5

9-45 Updated Locitite P/Ns

Rev. H summary of changes

Page	Description
Cover	Updated revision level
TOC	Updated all pages
1-1	Changed DraegerService Europe contact number, added Spare Parts section information
2-5	Changed illustration
2-6	Added new illustration
2-7	Removed 'that' from the last sentence on the first paragraph
2-9	Removed 'if' from first sentence in last paragraph
2-10	Changed illustration
2-11	Changed vol.% to 23 and removed 'inlet valve' vent' reference from figure
2-12	Changed vol.% to 23, changed max. O2 flow to 12 L/min, removed last sentence from first paragraph, removed 'inlet valve vent' and parenthesis from around 'SORC bypass', changed illustration
2-13	Changed various text
2-14	Removed 'volume control sensor' from item 2, added 'APL Valve' to item 2, deleted line after item 2, added 'port' onto illustration key text of item number 7 and added outline of #2 block to figure 2-13
2-15	Added illustration
2-14	Removed term 'dead space' in text, replaced illustration
2-16	Changed illustration
2-17	Added illustration
2-18	Changed illustration
2-19	Added text and illustration
2-20	Made last sentence of the last paragraph a paragraph, changed 'on the control box' to 'at the interface', added "Pressure" to heading, replaced illustration
2-21	Added illustration
2-22	Changed text and illustration
2-23	Added illustration
2-25	Added / between PEEP and Pmax, added /Pressure in heading, changed illustration
2-26	Added illustration

2-27 Added /Pressure to heading, changed illustration
2-28 Added illustration
2-29 Changed various text
2-31 Changed illustration
2-34 Added \ between PEEP and Pmax in heading
2-35 Changed illustration
2-37 Added 'PUMP' to "VACUUM" at LS1
2-39 Updated Main Service Screen illustration and updated text in illustration
key on item number 14
3-1 Changed the first entry in Table 3-1, Fuse, to External
3-2 Changed illustration
3-3 Changed figure caption
3-7 Updated Guide 1
3-8 Updated Guide 2
3-9 Updated Guide 3
3-10 Updated Guide 4
3-11 Updated Guide 5
3-12 Updated Guide 6
3-13 Updated Guide 7
3-14 Updated Guide 8
3-15 Updated Guide 9
3-16 Updated Guide 10
4-1 through 4-49 All pages have changed to incorporate new SW (screen shots,
associated text, new SW features)
5-2 Added NOTE, changed 5.1.6, changed first warning
5-3 Changed illustration
5-4 Changed step 5.1.9
5-5 Changed steps 5.2.6, 5.2.10, changed warning
5-6 Moved step 5.2.13 to 5.2.13.1, changed step 5.2.17
5-9 Updated statement under heading, changed second warning
5-12 Moved steps 5.5.12 through 5.5.15 to this page
5-14 Deleted steps 5.5.12 through 5.5.12.11 and moved balance of steps to page
5-12, moved all subsequent steps to this page. Caster Replacement -
changed Loctite in step 5.6.6
5-15 Changed illustration
5-16 Changed figure reference numbers to remove 'alpha' characters
5-18 Changed illustration, changed figure numbers and all references from
here to end
5-19 Changed figure number
5-20 Changed wording in step 5.7.18

5-21 Added 'overlap' to step 5.7.22, removed first statement from first sentence in step 5.7.23

5-22 Change illustration

5-23 Added new step 5.7.30

5-24 Changed figure reference number

5-25 (existing).....Delete heading 'Tech Sensor Disc and Encoder' and all subsequent steps associated with this heading, all data hereafter shifted up one page

5-27 Changed figure reference number

5-28 Changed figure number

5-29 Changed wording in step 5.9.5, changed figure reference number

5-30 Changed figure number

5-31 Changed figure reference number

5-32 Changed figure number

5-33 Added new step 5.11.2, added last NOTE

5-34 Added new steps 5.11.13 and 5.11.14

5-35 New Table

5-36 Figure number changed

5-37 Added new step 5.12.10

5-38 Changed figure number

5-39 .. Changed figure reference number and changed para. 5.13.4 and 5.13.5

5-40 Changed figure number

5-41 Changed steps 5.14.3 and 5.14.8, changed figure reference number

5-42 Changed figure number

5-43 Changed figure reference number

5-44 Changed figure number

5-45 . Changed first paragraph after heading, changed first NOTE, added new steps 5.16.6 and 5.16.7, changed steps 5.16.7 and 5.16.3

5-46 Moved illustration to this page

5-47 Changed figure reference number

5-48 Changed figure number

5-49 Changed figure reference number

5-50 Changed figure number

5-51 Changed figure reference number

5-52 Changed figure number

5-53 Changed figure reference number

5-54 Changed figure number

6-1 .. Removed 'Equipment Required' list, merged information from page 6-2, changed specification in paragraph 6.1.6

6-3 Changed para reference in para 6.1.12

6-10 Changed O2 concentrations in table under step 6.4.15

6-13 Changed Figure 6-6
6-15 Removed CAUTION
6-16 Updated illustration
6-18 Added new Section 6.10
7-2 Added last three repair tools
7-3 . Moved Diaphragm O-Ring to 1 year kit, made 'Used Batteries' lower case
7-16 Added new NOTE
7-17 Removed all reference to Convenience Outlet
7-19 . Deleted existing 7.4.3, changed paras.7.4.1, 7.4.2, 7.4.3, 7.4.7, 7.5.2, and
7.5.3
7-20 Deleted Caution, added paras. 7.5.7 and 7.5.8, changed paras. 7.6.2, 7.6.7
and 7.6.9
7-21 Switched steps 7.7.6 and 7.7.7, added new step 7.7.11 and associated
NOTE, changed (3x) to (5x) in step 7.7.10
7-22 Changed 'Stop Bits' to replace dash with comma in table within step
7.7.12
7-24 Added checkmark by para. 7.8
7-28 Added checkmark by para. 7.9.3
7-31 Deleted steps 7.9.4.6 and 7.9.6.7
7-42 Expanded in step 7.12.1.1
7-57 Changed step 7.7.11
7-58 Deleted checkmark from step 7.17.8
7-61 Changed para. 7.20.2
7-62 Changed paras. 7.20.26 and 7.20.32
7-64 Added (cmH₂O) to step 7.21.4.6
7-66 Added (cmH₂O) to step 7.21.7.6
7-67 Added (cmH₂O) to step 7.21.8.2
7-70 added (cmH₂O) to steps 7.22.2
8-1 Removed second paragraph on page
8-2 Added NOTE
8-5 Added NOTE
8-6 Changed step 8.4.2
8-11 Changed step 8.4.13, deleted 8.4.15
9-1 Updated TOC, removed Aux. Fresh Gas Outlet figure and lister page
9-2 Updated illustration
9-3 Updated parts list
9-4 Updated illustration
9-5 Updated parts list
9-6 Updated illustration
9-7 Updated parts list
9-12 Updated illustration

9-13	Updated parts list
9-14	Updated illustration
9-15	Updated parts list
9-16	Updated illustration
9-17	Updated parts list
9-18	Updated illustration
9-19	Updated parts list
9-20	Updated illustration
9-21	Updated parts list
9-22	Updated illustration
9-23	Updated parts list
9-24	Updated illustration
9-25	Updated parts list
9-26	Updated illustration
9-27	Updated parts list
9-28	Updated illustration
9-29	Updated parts list
9-30	Updated illustration
9-31	Updated parts list
9-32	Updated illustration
9-33	Updated parts list
9-36	Updated illustration
9-37	Updated parts list
9-41	Updated parts list

Rev. G summary of changes

Page	Description
Cover	Updated revision level
4-21	Added Caution

Rev. F summary of changes

Page	Description
Cover	Updated revision level
2-1	added trademark names
4-7	added error codes

4-9 added error codes
4-21 added caution to PEEP
4-27A..... changed para. to reference new table
6-2 changed psi in paras. 6.1.6 and 6.1.7
6-16 updated step 6.8.4, added note and caution
7-2 added item to repair tools
7-3 added 1 yr. PM kit
7-20 added new steps 7.5.5 and 7.5.6
7-21 rolled text from previous page
7-22 revised step 7.7.9
7-23 revised table
7-30 changed figure text
7-61 revised para. 7.20.11
7-64 changed PEEP settings
8-1 through 8-13..... revised all to reflect new download/upload procedures
9-5 added miscellaneous items
9-6 added new style APL Valve and Crater
9-7 changed P/N for Cap&Hose Barb Asm
9-12 added item 13 to illustration
9-13 added item 13
9-33 added battery
9-38 added item 18 to illustration
9-39 changed P/N and nomenclature of Ventilator,
 made typo changes to table
9-43 changed P/N for item 8

Rev. E summary of changes

Page	Description
Cover.....	Updated revision level
LOEP	Updated to reflect new revision levels, added new C page
4-10	Added acceptable range info., changed PVent value
5-27	Updated paras. 5.7.61 and 5.7.65
5-36	updated illustration
7-2	added P/N for washer, updated required materials
7-15	changed 3 month requirement to 6 month requirement
7-20	added new 7.4.1, updated old 7.4.1
7-21	moved text from following page to this page
7-22	added new para. 7.7.4, 7.7.6, 7.7.7, 7.7.9, 7.7.10, updated other steps to reflect new numbering

7-44 updated para. 7.12.3.2
 7-54 updated 7.15.2.1, added new illustration
 7-56 updated paras. 7.16.4.4 and 7.16.4.5
 7-59 replaced paras. 7.18.1.5 through 7.18.1.9, updated 7.18.2.4
 7-61 updated paras. 7.20.3 and 7.20.4
 7-63 added para. 7.21.2.3, deleted para. 7.21.3.5, updated paras. 7.21.1.1,
 7.21.3.2, 7.72.3.3
 7-65 updated paras. 7.21.6.1 and 7.21.7.8
 7-69 updated paras. 7.22.3, 7.22.4, and 7.22.5
 8-9 added new 8.3.1
 9-2 updated illustration to show new tray top
 9-3 added new #27, tray top
 9-5 changed P/N
 9-6 added new callouts for 11a, 12a, and 13a
 9-7 added new 11a, 12a, and 13a
 9-31 change P/N
 9-35 changed P/N for item #1
 9-38 added callouts for item nos., 13, 14, 15, 16, and 17
 9-39 added new 13, 14, 15, 16, and 17
 9-42 added callouts for item nos. 9, 10, 11, and 12
 9-43 added new 9, 10, 11, and 12, and miscellaneous items

Rev. D summary of changes

Page	Description
ii	Revised section headings 6.5 and 6.6
2-22	Added table for SW version vs ventilator neg pressure relief
2-24	Added table to Fig 2-21: SW version vs ventilator neg pressure relief
2-31	Revised Fig 2-26 to reflect sw 1.20
4-1, 4-2, 4-4	Revised Figs 4-1, 4-2, 4-4 to reflect sw 1.20
4-19	Revised Fig 4-16 to show current offset value for vent pressure
4-21	Revised Fig 4-18 to reflect sw 1.30
4-22	Revised Fig 4-19 caption
4-23	Added Fig 4-20A to show sw 1.30 screen
4-27A	Added Fig 4-24B to show sw 1.30 screen
5-27	Added Notes to ref P/L for correct patient asm & neg press relief valve
5-28	Text spillover to accommodate notes on previous page

5-35 Added note to verify software level of replacement control PCB
5-36 Revised table of market kit settings to include 6 more countries

6-4 Revised compensated cyl press regulator output table
6-14 Revised title: Pressure Calibration
6-15 Revised title: Fresh Gas Flow Calibration
6-17 Revised Fig 6-8 to reflect sw 1.30

7-2 Added vapor test hose to test equip list
7-28, 7-29 Revised breathing sys leak test for two software versions
7-37 Re-labeled PEEP/Pmax valve on illustration
7-61 Added note for SW >1.20: threshold low alarm
7-67, 7-68 . Revised aux air valve & piston leak test for two software versions
7-70 Added step No Fresh Gas alarm check on SW version 1.30

8-1, 8-2 Revised page layout for added software version notes
8-8 thru 8-11 Revised page layout to expand table of market kit settings

9-7 Revised PEEP/Pmax valve diaphragm asm P/N
9-31 Various nomenclature revisions
9-32, 9-33 Revised Controller PCB P/L, re-numbered callouts
9-38, 9-39 Revised illus & P/L for neg press vent valve P/N vs SW version